

THIS DRAWING IS UNPUBLISHED. RELEASED FOR PUBLICATION
 © COPYRIGHT 2005 By - ALL RIGHTS RESERVED.

| LOC | | DIST | | REVISIONS | | | |
|-----|-----|-------------|---------------------------|-----------|------|----|--|
| P | LTR | DESCRIPTION | DATE | DWN | APVD | | |
| GP | 00 | Z | REVISED PER ECO-14-011808 | 09AUG2014 | AP | SB | |

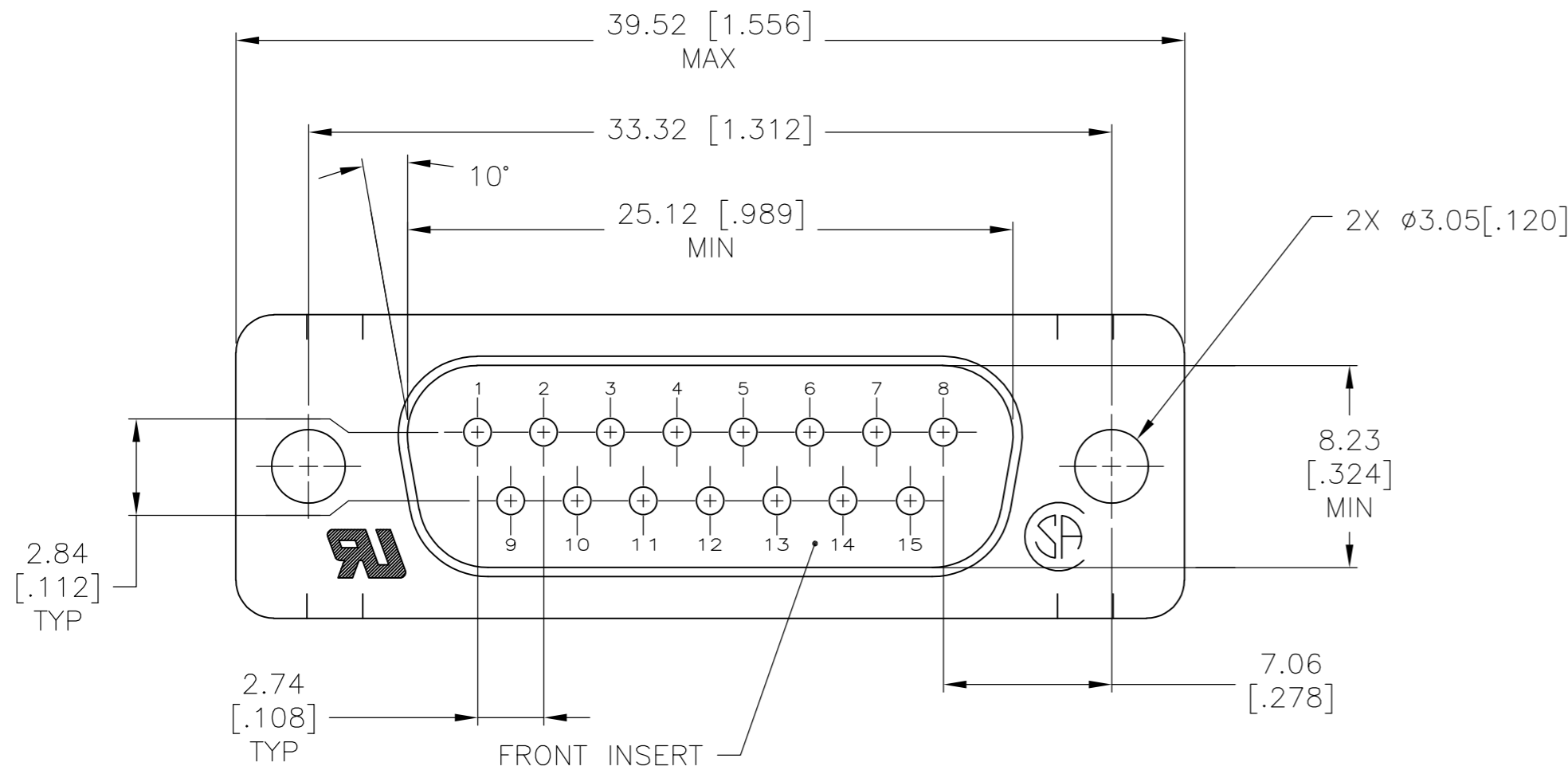

- ⚠ MOLDED PARTS: GLASS-FILLED PBT OR GLASS-FILLED NYLON, UL94V-0 RATED. COLOR: BLACK
- SHELLS: CARBON STEEL
- CONTACTS: BRASS
- ⚠ SHELLS: 5.08µm [.000200] MIN ZINC WITH YELLOW CHROMATE COATING.
- CONTACTS: GOLD PLATED FOR LENGTH OF 3.81 [.150] MIN FROM MATING END, 0.76µm [.000030] MIN GOLD IN MATED AREA, 2.54µm [.000100] MIN TIN-LEAD ON SOLDER END, BOTH OVER 1.27µm [.000050] MIN NICKEL.
- OR
- GOLD FLASH OVER PALLADIUM-NICKEL PLATED FOR LENGTH OF 3.81 [.150] MIN FROM MATING END, 0.76µm [.000030] MIN TOTAL IN MATED AREA, 2.54µm [.000100] MIN TIN-LEAD ON SOLDER END, BOTH OVER 1.27µm [.000050] MIN NICKEL.
- 3. NOTE DELETED.
- 4. NOTE DELETED.
- 5. NOTE DELETED.
- ⚠ NOTE DELETED.

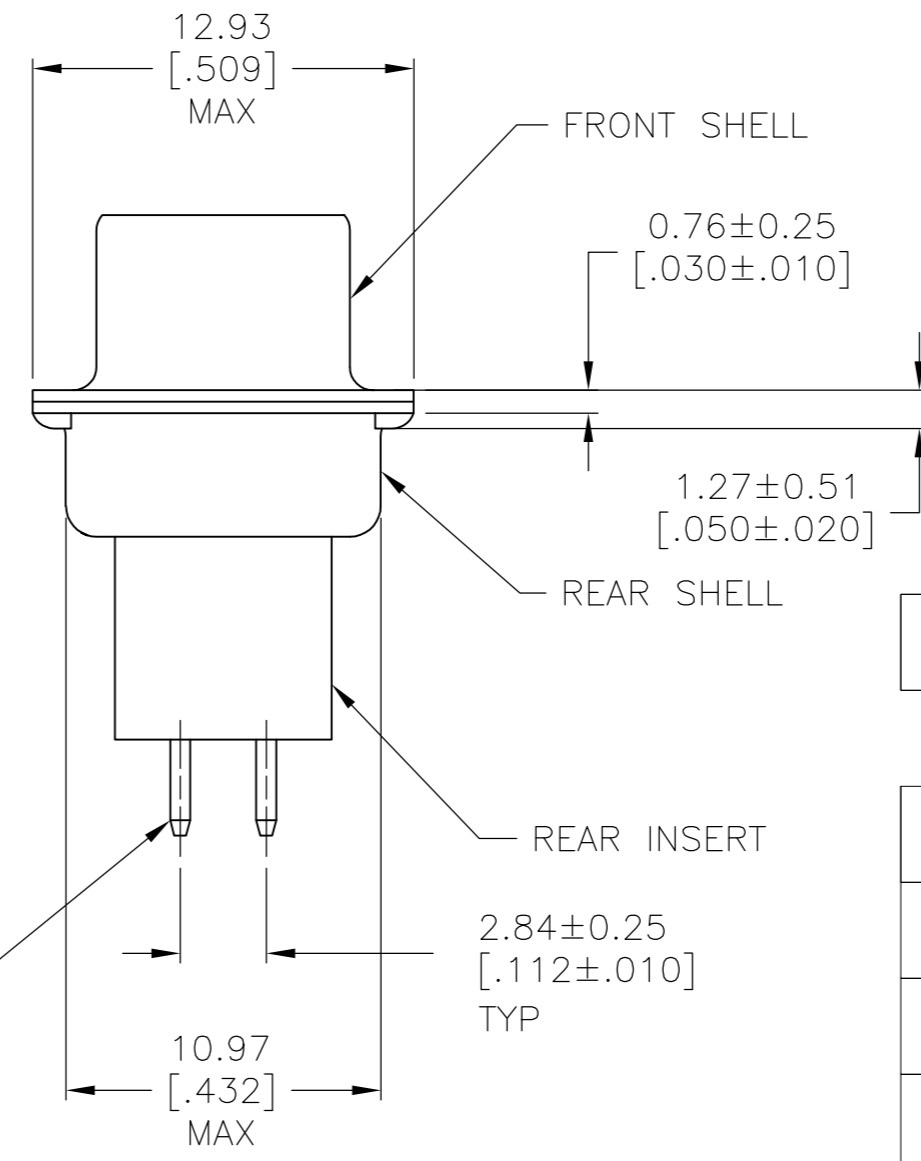
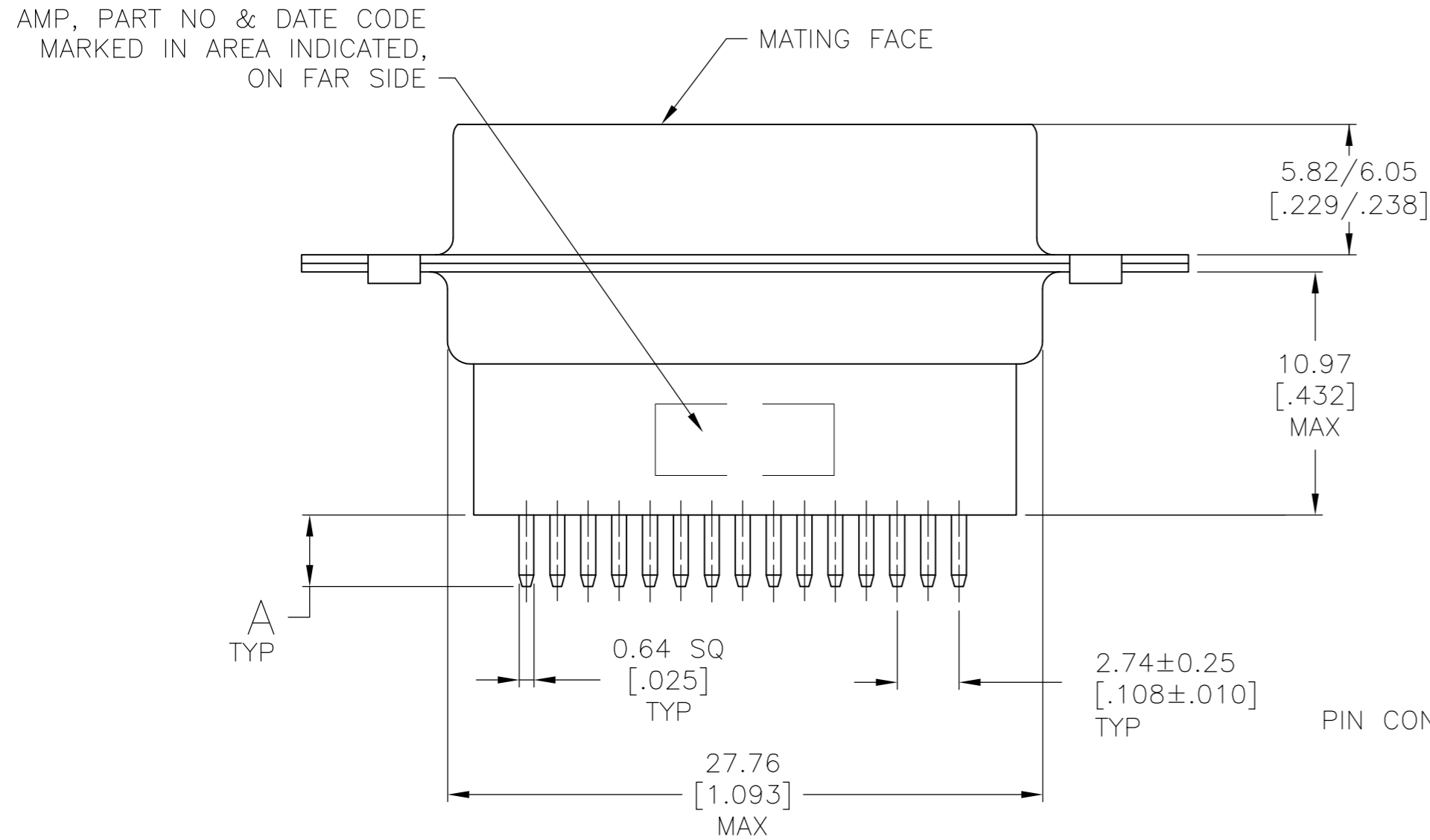

| | | | |
|-------------------|--------|--------------|-------------|
| SUPSD BY 205735-7 | - | - | 205735-8 |
| | ⚠ | 4.78 [.188] | 205735-7 |
| SUPSD BY 205735-5 | - | - | 205735-6 |
| SUPSD BY 745411-1 | - | 16.54 [.651] | 205735-5 |
| SUPSD BY 745411-1 | - | 10.85 [.427] | 205735-4 |
| OBSOLETE | - | - | 205735-3 |
| SUPSD BY 205735-1 | - | - | 205735-2 |
| SUPSD BY 745411-1 | - | 3.18 [.125] | 205735-1 |
| | FINISH | A | PART NUMBER |

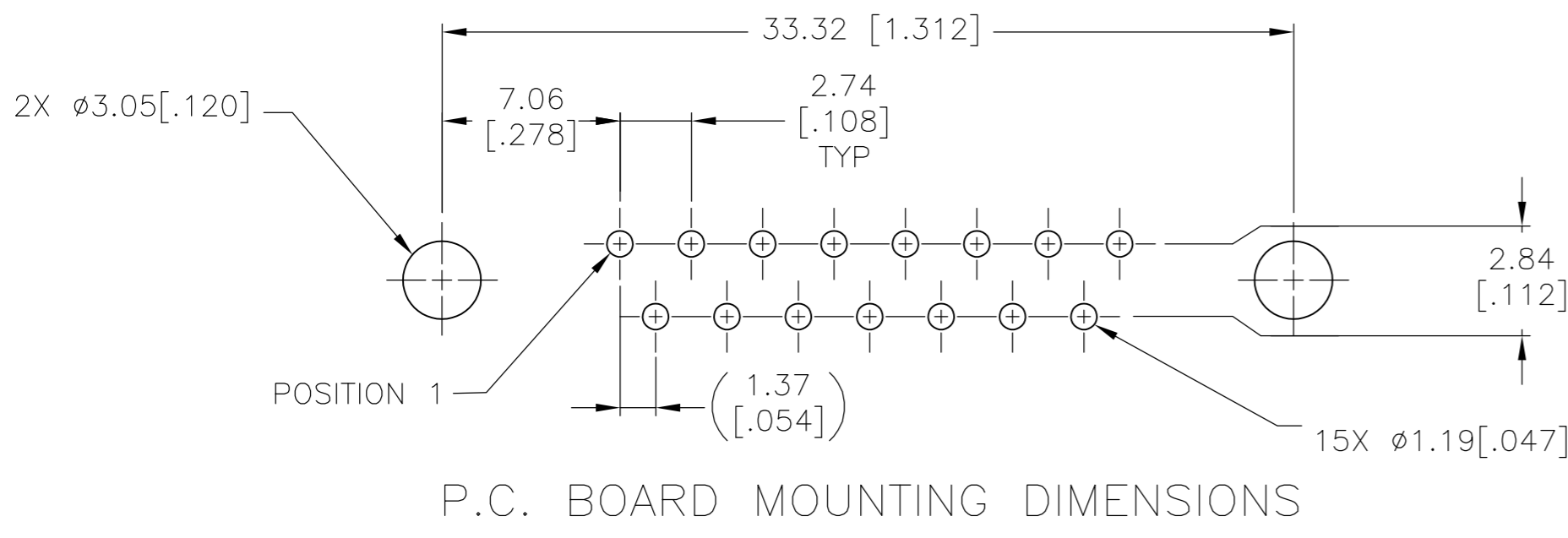

THIS DRAWING IS A CONTROLLED DOCUMENT.

| | | | |
|-------------------------|--|----------------------------|------------------------------|
| DIMENSIONS: mm [INCHES] | TOLERANCES UNLESS OTHERWISE SPECIFIED: | DWN J. POLIGNONE 01FEB07 | TE Connectivity |
| | 0 PLC ± - | CHK E. BRIANT 01FEB07 | |
| | 1 PLC ± - | APVD E. BRIANT 01FEB07 | |
| | 2 PLC ± 0.13 [.005] | NAME | |
| | 3 PLC ± - | PRODUCT SPEC 108-40025 | |
| MATERIAL | FINISH | APPLICATION SPEC 114-40013 | RESTRICTED TO |
| 1 | 2 | WEIGHT - | A2 00779 C=205735 |
| CUSTOMER DRAWING | | | SCALE NTS SHEET 1 OF 1 REV Z |