

ACMSN2312T-HF

N-Channel
RoHS Device
Halogen Free

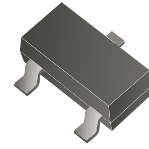

Features

- Advanced trench process technology.
- Lower on-resistance.
- Reliable and rugged.
- Electrostatic sensitive devices.
- AEC-Q101 Qualified.

Mechanical data

- Case: SOT-23, molded plastic.

Circuit Diagram

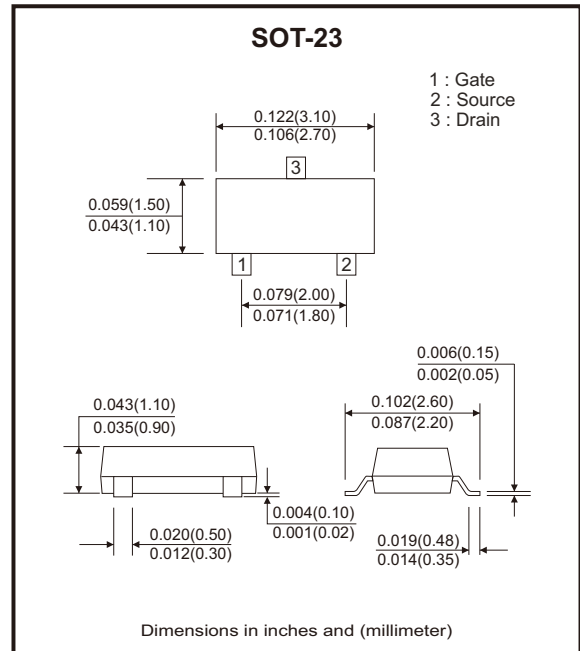
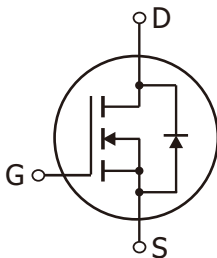

Maximum Ratings (at Ta=25°C unless otherwise noted)

Parameter	Symbol	Value	Unit
Drain-source voltage	V _{DSS}	20	V
Gate-source voltage	V _{GSS}	±8	V
Maximum drain current	I _D	4.9	A
Pulsed drain current	I _{DM}	15	A
Power dissipation	P _D	0.75	W
Thermal resistance, junction to ambient (PCB mounted)	R _{θJA}	140	°C/W
Operating junction and storage temperature range	T _J , T _{STG}	-55 to +150	°C

Electrical Characteristics (at Ta=25°C unless otherwise noted)

Parameter	Symbol	Conditions	Min	Typ	Max	Unit
Drain-source breakdown voltage	$V_{(BR)DSS}$	$V_{GS} = 0V, I_D = 250\mu A$	20			V
Gate threshold voltage	$V_{GS(th)}$	$V_{DS} = V_{GS}, I_D = 250\mu A$	0.4		1.2	V
Forward transconductance	g_{fs}	$V_{DS} = 15V, I_D = 5A$		40		S
Gate-body leakage	I_{GSS}	$V_{DS} = 0V, V_{GS} = 8V$			100	nA
		$V_{DS} = 0V, V_{GS} = -8V$			-100	
Zero gate voltage drain current	I_{DSS}	$V_{DS} = 20V, V_{GS} = 0V$			1	μA
Drain-source on resistance	$R_{DS(on)}$	$V_{GS} = 4.5V, I_D = 5A$		21	31	m Ω
		$V_{GS} = 2.5V, I_D = 4.5A$		24	37	
		$V_{GS} = 1.8V, I_D = 4A$		50	85	
Drain forward voltage	V_{SD}	$V_{GS} = 0V, I_S = 1.8A$			1.2	V
Total gate charge	Q_g	$V_{DS} = 10V, V_{GS} = 4.5V, I_D = 5A$		11.2	14	nC
Gate-source charge	Q_{gs}			1.4		
Gate-drain charge	Q_{gd}			2.2		
Input capacitance	C_{iss}	$V_{DS} = 8V, V_{GS} = 0V, f = 1MHz$		500		pF
Output capacitance	C_{oss}			300		
Reverse transfer capacitance	C_{rss}			140		
Turn-on delay time	$t_{d(on)}$	$V_{DD} = 10V, I_D = 1A, R_G = 6\Omega, V_{GEN} = 4.5V, R_L = 10\Omega$		15	25	nS
Rise time	t_r			40	60	
Turn-off delay time	$t_{d(off)}$			48	70	
Fall time	t_f			31	45	
Max. diode forward current	I_S				1.7	A

Rating and Characteristic Curves (ACMSN2312T-HF)

Fig.1 - Transfer Characteristics

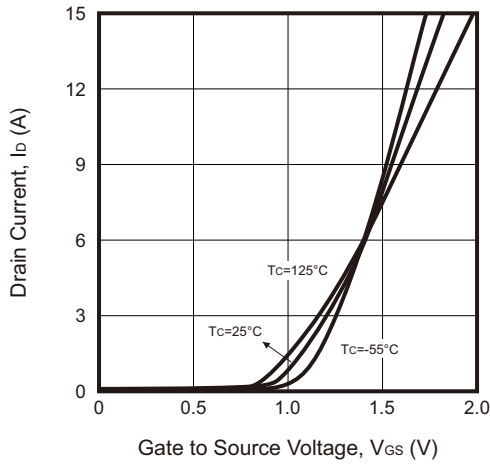

Fig.2 - On-Resistance vs. Drain Current

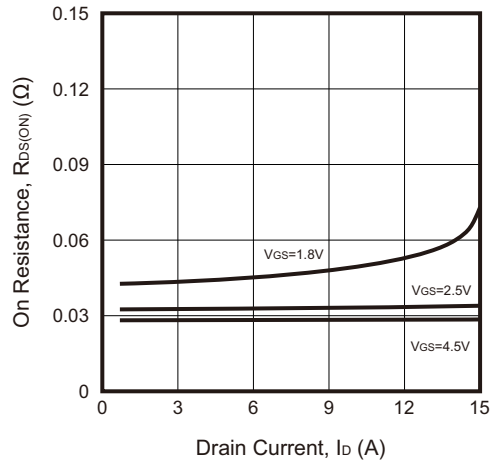

Fig.3 - Capacitance

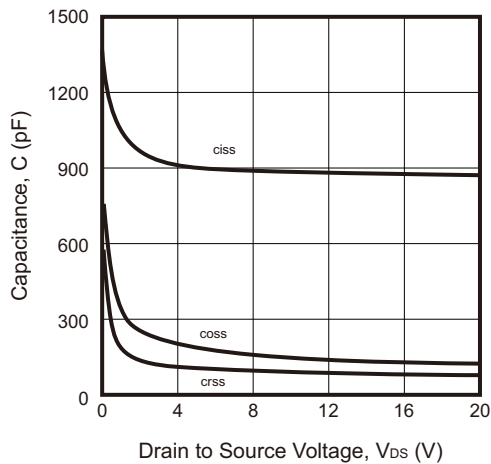

Fig.4 - On-Resistance vs. Gate to Source Voltage

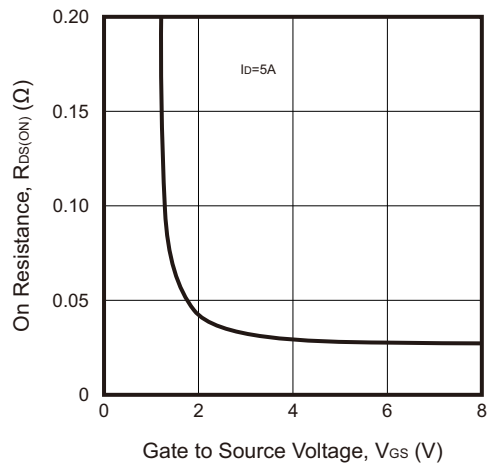
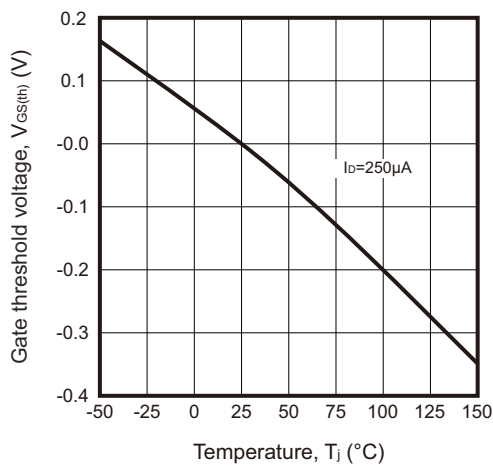
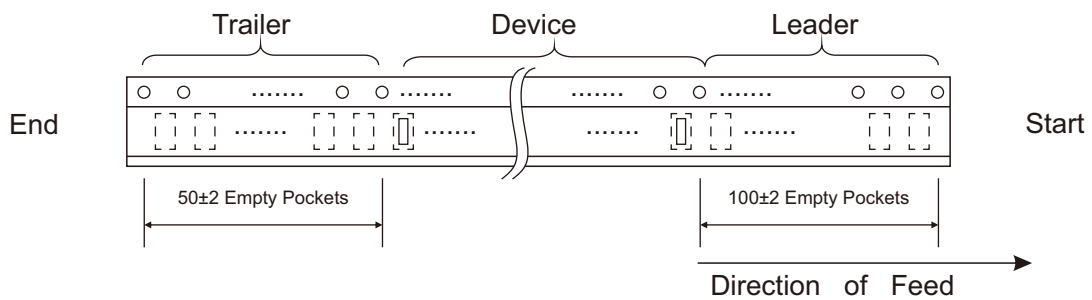
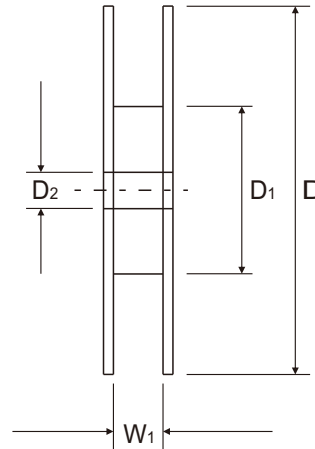
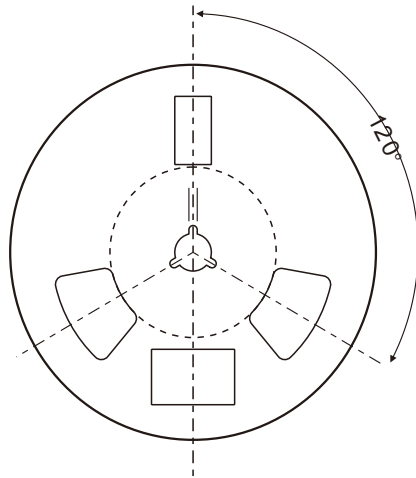
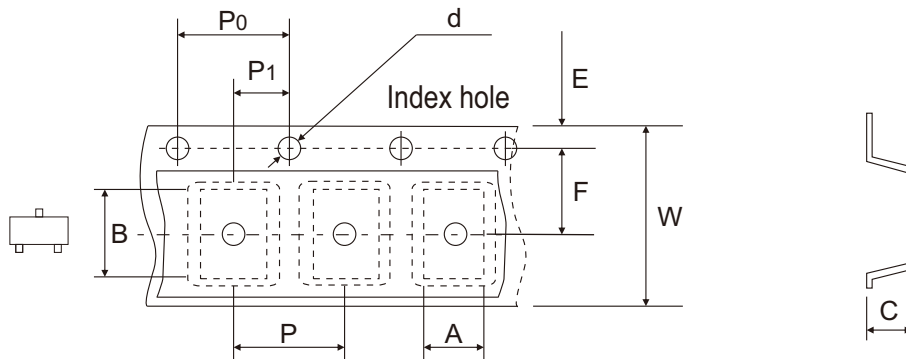

Fig.5 - Threshold Voltage



Company reserves the right to improve product design, functions and reliability without notice.

Reel Taping Specification



SOT-23	SYMBOL	A	B	C	d	D	D1	D2
	(mm)	3.15 ± 0.10	2.77 ± 0.10	1.22 ± 0.10	1.50 ± 0.10	178.00 ± 1.00	54.00 ± 0.50	13.00 ± 0.50
	(inch)	0.124 ± 0.004	0.109 ± 0.004	0.048 ± 0.004	0.059 ± 0.004	7.008 ± 0.039	2.126 ± 0.020	0.512 ± 0.020

SOT-23	SYMBOL	E	F	P	P0	P1	W	W1
	(mm)	1.75 ± 0.10	3.50 ± 0.05	4.00 ± 0.10	4.00 ± 0.10	2.00 ± 0.05	8.00 + 0.30 - 0.10	9.50 ± 1.00
	(inch)	0.069 ± 0.004	0.138 ± 0.002	0.157 ± 0.004	0.157 ± 0.004	0.079 ± 0.002	0.315 + 0.012 - 0.004	0.374 ± 0.039

Company reserves the right to improve product design , functions and reliability without notice.

REV:A

Marking Code

Part Number	Marking Code
ACMSN2312T-HF	2312

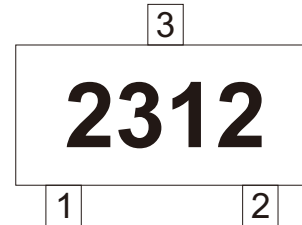

Suggested P.C.B. PAD Layout

SIZE	SOT-23	
	(mm)	(inch)
A	0.90	0.035
B	0.80	0.031
C	0.95	0.037
D	2.00	0.079
E	2.90	0.114

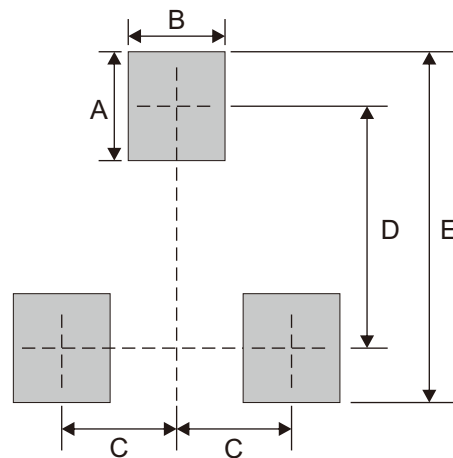

Note: 1. The pad layout is for reference purposes only.

Standard Packaging

Case Type	REEL PACK	
	REEL (pcs)	Reel Size (inch)
SOT-23	3,000	7