

PART NUMBER	REV	FIRST USED
1852293-1	A	122500-1
1852293-2	A	565435-5
1852293-3	A	354500-1

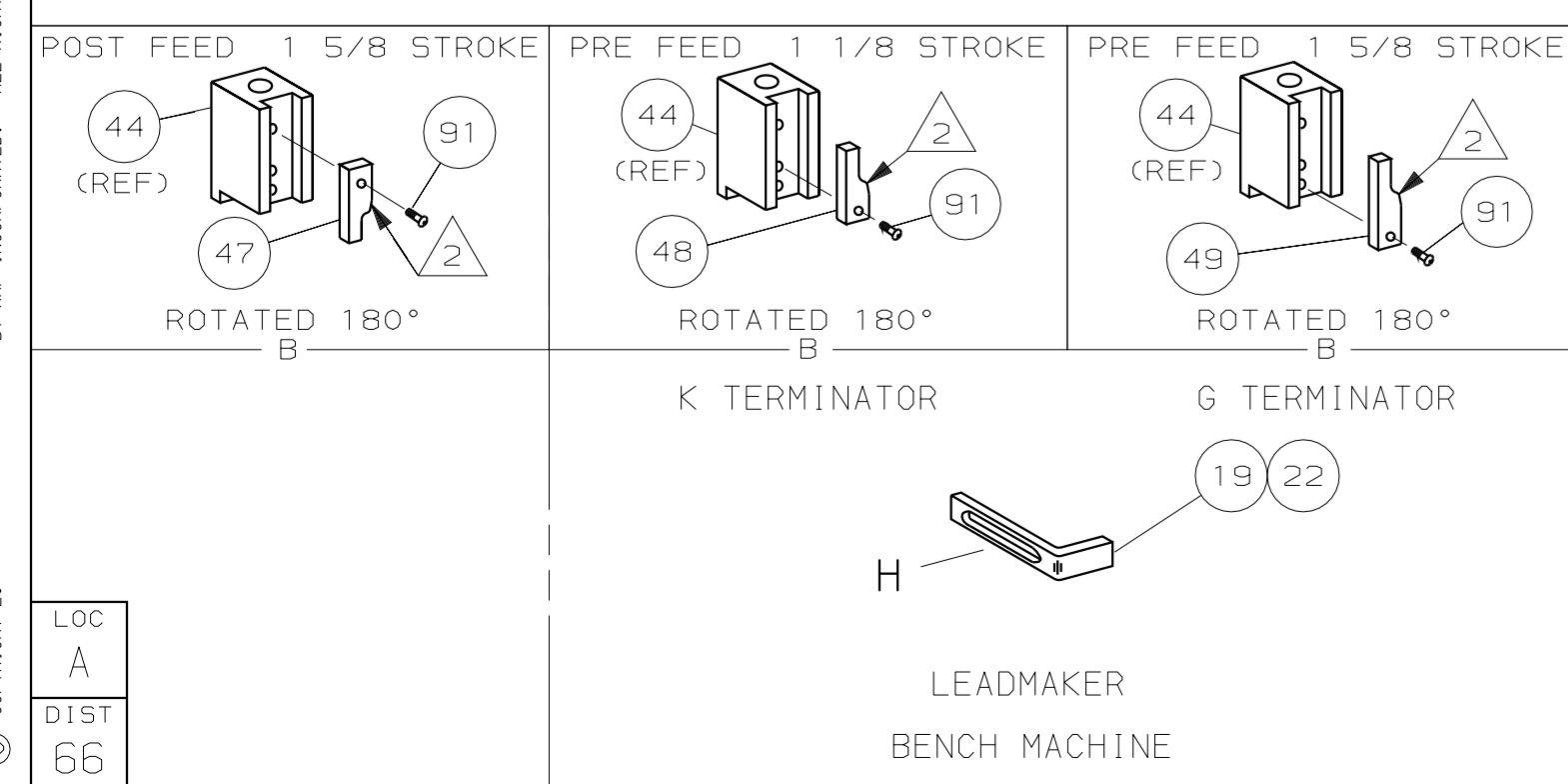
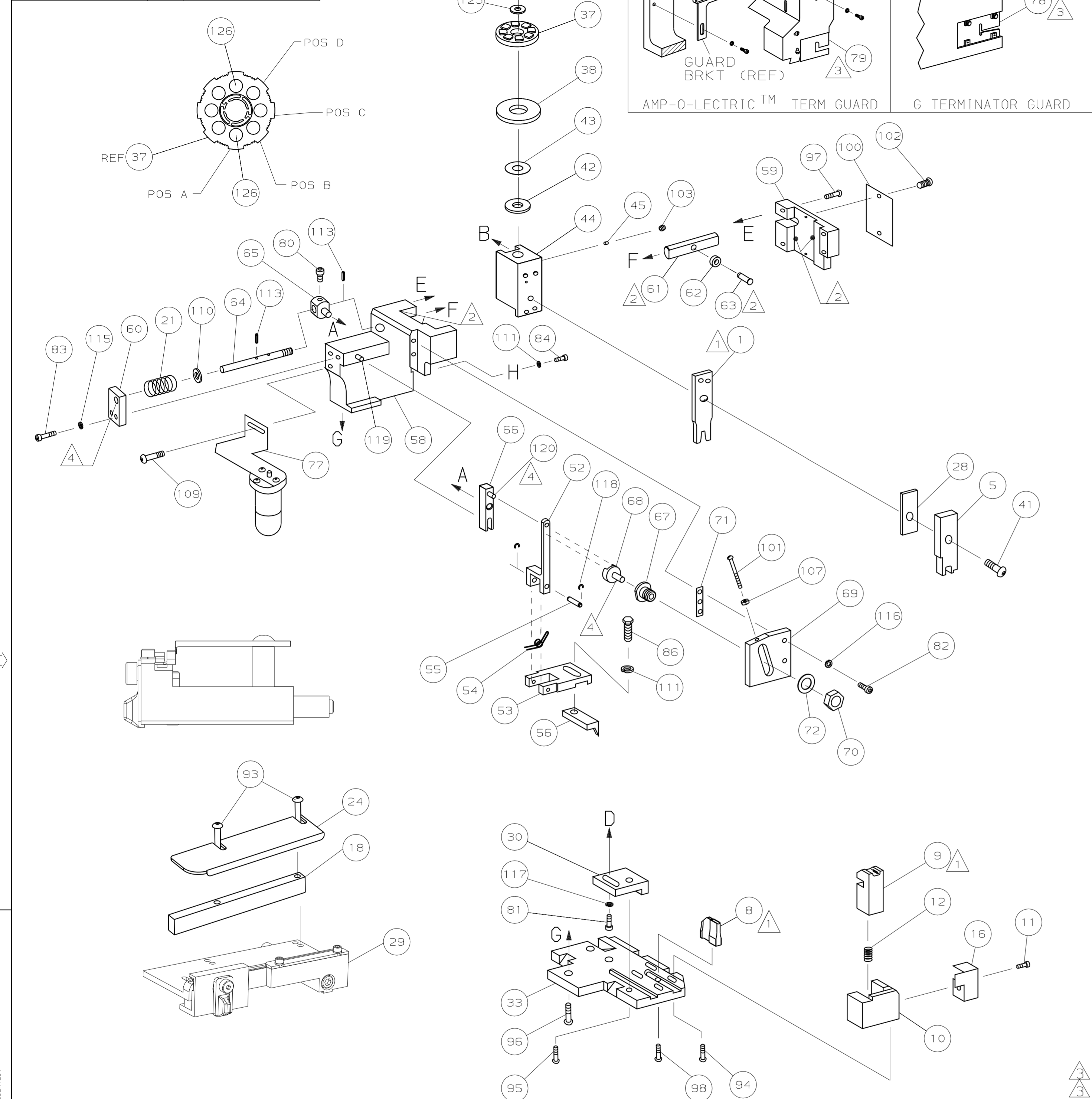

- 1 RECOMMENDED SPARE PARTS.
- 2 GREASE LIGHTLY.
- 3 GUARD MUST BE IN PLACE WHEN OPERATING APPLICATOR IN A BENCH MACHINE.
- 4 LUBRICATE DAILY USING NO. 20 MACHINE OIL.
- 5. ITEMS WITH QTY OF REF SPECIFIED (EXCEPT ITEMS 78 AND 79) ARE USED ON ITEM 46.

TERMINAL NAME: SPLICE		AMP TERMINAL		AMP CRIMP SPECS	
PAD LTR	CRIMP HEIGHT	WIRE SIZE			
A	.109 ±.002 [2.77 ±0.05mm]	(5)18 8,000CMA			
B	NOT	USED			
C	NOT	USED			
D	NOT	USED			
CRIMP	SIZE	TYPE	RANGE		
WIRE	.180 [4.57mm]	F	5,000-16,000 CMA		
INSUL	-	-	-		

QTY	REF	REF	REF	U/M	DWG SIZE	PART NO	DESCRIPTION	ITEM NO
2	2	2	-	C		2-354779-8	PIN, WIRE DISC (.3130)A	126
1	1	1	-	A		986950-1	WASHER, FLAT PRECISION	125
1	1	1	-	A		217238-1	GENERAL INSTRUCTION PACKAGE	124
1	1	1	-	-		4088040	SF APPL INST 408-8040	123
1	1	1	-	A		4-21028-0	PIN,SLT SPR(Ø.093x.75)ST GDE PL	121
REF	REF	REF	-	A		1-21030-1	PIN,DOWEL(Ø.187x.50)LEVER	120
REF	REF	REF	-	A		1-21030-6	PIN,DOWEL(Ø.187x1.25)HOUSING	119
REF	REF	REF	-	A		21045-3	RING,RET "C"(Ø.187)FD FING PIN	118
1	1	1	-	A		21024-5	WASHER, LOCK (#10)ADJ BLOCK	117
REF	REF	REF	-	A		21024-5	WASHER,LOCK(#10)ADJ PLATE	116
REF	REF	REF	-	A		21024-5	WASHER,LOCK(#10)FEED GDE ROD	115
2	2	2	-	A		21024-2	WASHER,LOCK(#4)FRONT STP GUIDE	114
REF	REF	REF	-	A		5-21028-1	PIN,SLT SPR(Ø.125x.50)ADJ ROD	113
2	2	2	-	A		21024-4	WASHER,LOCK(#8)STRIPPER	111
REF	REF	REF	-	A		21899-4	WASHER,FLAT(Ø5/16)SCREW ADJ	110
-	1	-	-	A		2-21002-6	SCR,BHC(10-32x.38)LUBE ASSY	109
REF	REF	REF	-	A		21068-5	NUT,HEX(6-32)FEED ADJ	108
1	1	1	-	A		21009-2	SCR,SKT SET(1/4-20x.25 LW)RAM	103
2	2	2	-	A		21017-2	SCR,DRIVE(#2x.19)ID PLATE	102
REF	REF	REF	-	A		6-23715-5	SCR,PAN HD(6-32x1.50)FEED ADJ	101
1	1	1	-	B		461264-1	PLATE, IDENTIFICATION	100
2	2	2	-	A		3-21002-0	SCR,BHC(10-32x.88)DRAG	99
1	1	1	-	A		22733-8	SCR,BHC(8-32x.38 LW)ANVIL	98
REF	REF	REF	-	A		2-21002-9	SCR,BHC(10-32x.75)CAP	97
REF	REF	REF	-	A		2-22733-8	SCR,BHC(1/4-20x.62)HOUSING	96
REF	REF	REF	-	A		2-21002-7	SCR,BHC(10-32x.50)SG ADJ BLOCK	95
4	4	4	-	A		2-21002-2	SCR,BHC(8-32x.50)TERM H DWN	94
2	2	2	-	A		2-21002-4	SCR,BHC(8-32x.75)TERM H DWN	93
1	1	1	-	A		1-21002-7	SCR,BHC(6-32x.38)CAM	91
1	1	1	-	A		2-22603-0	SCR,HEX HD(8-32x.31)FEED FINGER	86
2	2	2	-	A		1-21000-3	SCR,SHC(4-40x.25)FR ST GUIDE	85
1	1	1	-	A		2-21000-7	SCR,SHC(8-32x.50)STRIPPER	84
REF	REF	REF	-	A		3-21000-7	SCR,SHC(10-32x.75)FEED ROD GD	83
REF	REF	REF	-	A		3-21000-6	SCR,SHC(10-32x.62)FD ADJ BLK	82
1	1	1	-	A		3-21000-4	SCR,SHC(10-32x.38)SG ADJ BL	81
REF	REF	REF	-	A		3-21000-4	SCR,SHC(10-32x.38)PIVOT BLK	80
-	REF	-	-	B		455749-1	GUARD, WINDOW	79
REF	-	-	-	B		679532-1	INSERT, GUARD	78
-	1	-	-	C		1-465184-0	LUBRICATOR ASSY	77
								76
								75
								74
								73
								72
REF	REF	REF	-	A		458109-1	WASHER, SPECIAL	71
REF	REF	REF	-	A		690517-1	SPACER	71

QTY	REF	REF	REF	U/M	DWG SIZE	PART NO	DESCRIPTION	ITEM NO
-1							LEADMAKER	
-2							BENCH MODEL K	MECH POST FEED
-3							BENCH MODEL G	MECH PRE FEED
REF	REF	REF	-	B		22594-8	NUT,HEX(1/2-20)	70
REF	REF	REF	-	B		240628-1	PLATE, ADJUSTMENT	69
REF	REF	REF	-	B		240626-1	SHAFT, PIVOT	68
REF	REF	REF	-	B		240633-1	BUSHING	67
REF	REF	REF	-	A		455680-1	LEVER, INTERMEDIATE	66
REF	REF	REF	-	B		240629-1	BLOCK, PIVOT	65
REF	REF	REF	-	A		240632-2	SCREW, ADJ FEED ROD	64
REF	REF	REF	-	B		240659-3	PIN, CAM ROLLER	63
REF	REF	REF	-	B		240658-1	ROLLER, CAM	62
REF	REF	REF	-	B		454398-2	ROD, FEED	61
REF	REF	REF	-	A		454178-1	GUIDE, FEED ROD	60
REF	REF	REF	-	C		454220-1	CAP, RAM	59
REF	REF	REF	-	D		454485-1	HOUSING	58
								57
1	1	1	-	B		458537-4	PAWL, FEED	56
REF	REF	REF	-	B		240624-1	PIN, FEED FINGER	55
REF	REF	REF	-	B		691499-1	SPRING, FEED FINGER	54
REF	REF	REF	-	B		690541-1	HOLDER, FEED FINGER	53
REF	REF	REF	-	A		455679-1	LEVER, TERMINAL FEED ARM	52
								51
								50
1	-	-	-	B		690602-6	CAM, PRE-FEED 1 5/8 ST	49
-	1	-	-	B		690602-5	CAM, PRE-FEED 1 1/8 ST	48
-	-	1	-	B		690501-4	CAM, POST-FEED 1 5/8 ST	47
1	1	1	-	B		459456-2	APPLICATOR, BASIC (SUBASSY)	46
1	1	1	-	A		690191-1	PLUG, NYLON	45
1	1	1	-	C		455673-5	RAM	44
1	1	1	-	A		690125-1	WASHER, LAMINATED	43
1	1	1	-	A		690124-1	WASHER, RAM	42
1	1	1	-	A		7-21002-9	BOLT, CRIMPER(5/16x1.00)	41
								40
								39
1	1	1	-	A		690223-2	SPACER, INSULATION DISC	38
1	1	1	-	D		354777-1	DISC, WIRE	37
1	1	1	-	A		22480-5	WASHER, SPRING	36
1	1	1	-	B		690212-1	POST, RAM	35
								34
REF	REF	REF	-	D		455675-1	PLATE, BASE	33
								32
								31
								30
1	1	1	-	C		1633091-1	PLATE, STRIP GUIDE	29
1	1	1	-	C		1-455888-0	SPACER, FRONT SHEAR DEP	28
								27
								26
1	1	1	-	D		6-690440-5	GUIDE, STRIP (REAR)	24
-	-	1	-	B		690472-2	STRIPPER	22
REF	REF	REF	-	A		4-22284-9	SPRING, FEED RETURN	21
								20
1	1	-	-	B		691353-1	STRIPPER	19
1	1	1	-	B		1-1320908-3	SPACER, STRIP GUIDE	18
								17
1	1	1	-	B		318563-1	GUARD, CHIP, FRONT	16
								15
								14
								13
1	1	1	-	A		3-22280-3	SPRING, SHEAR	12
1	1	1	-	B		690461-2	STOP, SHEAR	11
1	1	1	-	C		1-690459-0	HOLDER, SHEAR (FRONT)	10
1	1	1	-	C		454276-5	SHEAR, FLOAT (FRONT)	9
1	1	1	-	C		5-1633117-3	ANVIL	8
								7
								6
1	1	1	-	C		2-455889-0	DEPRESSOR, SHEAR (FRONT)	5
								4
								3
								2
1	1	1	-	C		1-456412-1	CRIMPER, WIRE	1