

THIS DRAWING IS UNPUBLISHED. RELEASED FOR PUBLICATION - .N/A .
 © COPYRIGHT N/A BY TYCO ELECTRONICS CORPORATION. ALL RIGHTS RESERVED.

LOC	DIST	REVISIONS					
DF	S5	P	LTR	DESCRIPTION	DATE	DWN	APVD
		G		REV PER ECO-05-002582	06-05	AA	DE

PART NUMBER	DIM A	REMARKS
849310-1	12.00 [304.8]	OBSOLETE
849310-2	18.30 [464.8]	OBSOLETE
849310-3	23.80 [604.5]	③
849310-4	28.00 [711.2]	③
849310-5	39.00 [990.6]	③
849310-6	26.00 [660.4]	③
849310-7	25.00 [635.0]	OBSOLETE
5-849310-3	23.80 [604.5]	④

- ① TOLERANCE OF LEAD LENGTH:
UP TO 24 INCHES [609.6] = ±.12 [3.0]
24 INCHES [609.6] & UP = 1%
- ② COLOR OF LEAD WIRE:
WHITE UNLESS OTHERWISE SPECIFIED.
- ③ PIGTAIL SOLDER DIPPED.
- ④ INSULATION CUT TO LENGTH, BUT NOT REMOVED.

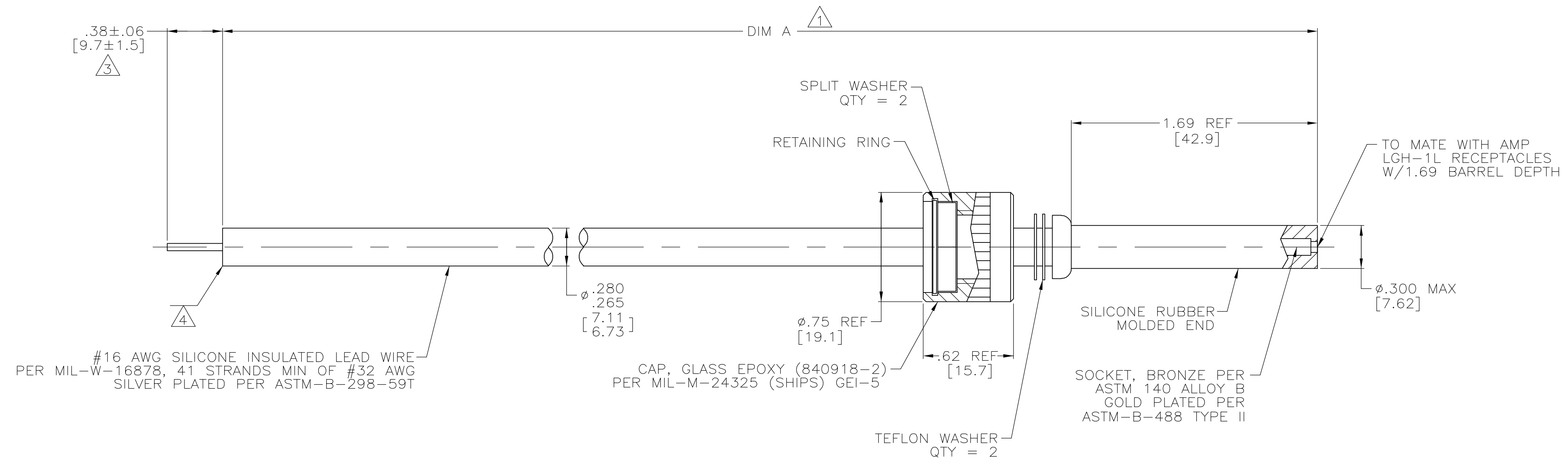

THIS DRAWING IS A CONTROLLED DOCUMENT.		DWN DICK STONE 19-APR-78	tyco Electronics		Tyco Electronics Corporation Harrisburg, Pa 17105-3608	
DIMENSIONS: INCHES		CHK J.W.SHAW 05-FEB-81	NAME LEAD ASSEMBLY, SINGLE MOLDED END LGH-1L W/REMOVABLE CAP			
TOLERANCES UNLESS OTHERWISE SPECIFIED:		APVD J.W.SHAW 05-FEB-81	SIZE A2			
0 PLC ± -		PRODUCT SPEC	CAGE CODE 00779			
1 PLC ± -		APPLICATION SPEC	DRAWING NO C=849310			
2 PLC ± .04			RESTRICTED TO			
3 PLC ± .015			SCALE 2:1			
4 PLC ± -			SHEET 1 OF 1			
ANGLES ± -			REV G			
FINISH SEE CALLOUTS		WEIGHT -	CUSTOMER DRAWING			