

# OA254LFG Series

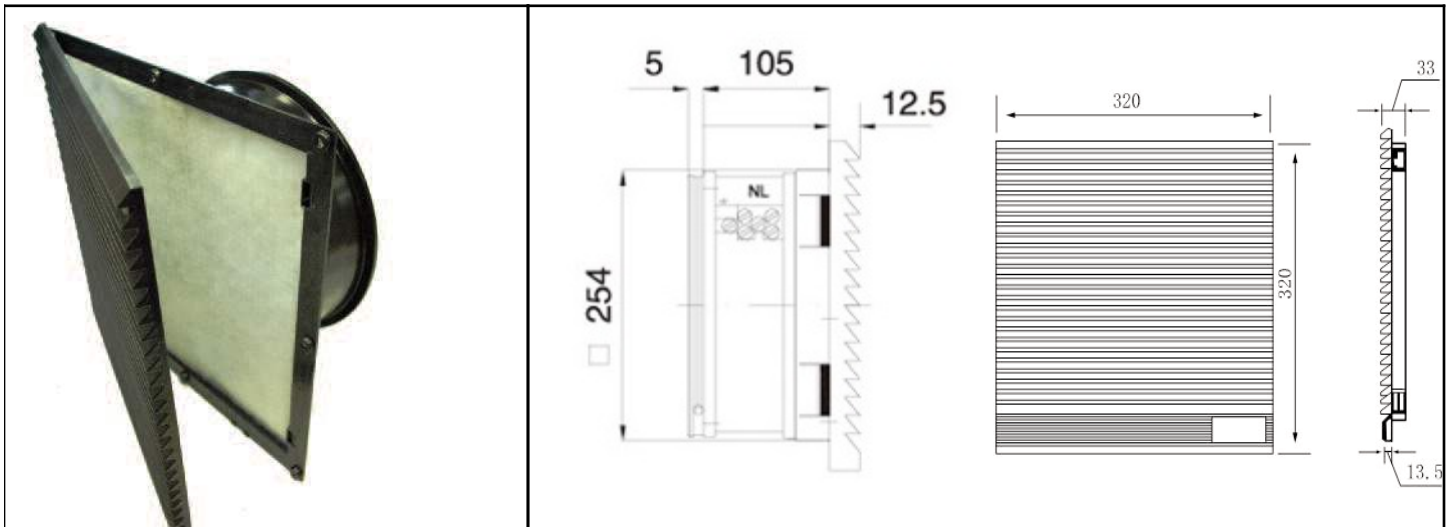

## Louvered Filter Fan Kit with Fan Installed



Frame	Diecast Aluminum	Operating Temperature Ball Bearing -20C ~ +80C  Life Expectancy Ball Bearing 60,000 hours (L10 at 40C)  Environmental: Class B Insulation Rated IP54 Guard Guard Frame: ABS Resin UL94V-0 with UV protection Color: Black (standard) or Gray Filter Mesh: Nylon fiber Synthetic Resin m2
Impeller	PBT, UL94V-O plastic	
Connection	2x Lead Wires or Terminals	
Motor	Capacitor drive, thermally protected	
Bearing System	Dual ball	
Insulation Resistance	>100M ohm between lead-wire and frame (500VDC)	
Dielectric Strength	1 min at 1500 VAC, 50/60Hz	

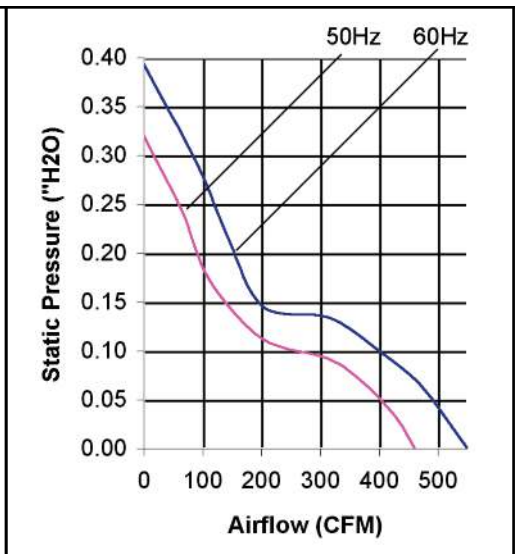

Part Number	OA254LFG111T	OA254LFG221T
Nominal Voltage (50/60 Hz)	115VAC	230VAC
Voltage Range	80 ~ 130VAC	160 ~ 260VAC
Rated Power	31/33 W (0.30 / 0.29 A)	31/33 W (0.14 / 0.14 A)
Rated Speed	1400 / 1650	1400 / 1650
Airflow - CFM	460 / 547	460 / 547
Noise Level - dB	52 / 55	52 / 55
Max. Static Pressure	0.32" / 0.39" H <sub>2</sub> O	0.32" / 0.39" H <sub>2</sub> O

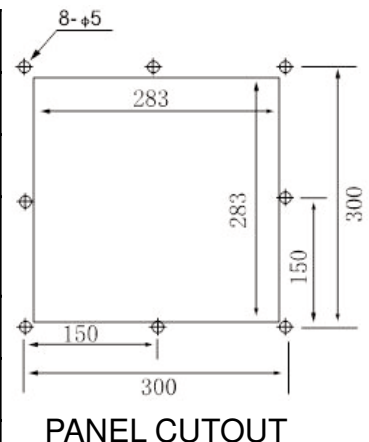

\* Note: Airflow data is for the fan without the louvered filter attached. Calculations indicate that up to a 40% reduction (~ 276 / 328 CFM) in fan airflow is possible with LFG unit installed.