

Clock Generator for Intel® Crestline Chipset

Features

- Compliant to Intel® CK505
- Low power push-pull type differential output buffers
- Integrated voltage regulator
- Integrated resistors on differential clocks
- Scalable low voltage VDD_IO (3.3V to 1.25V)
- Differential CPU clocks with selectable frequency
- 100 MHz Differential SRC clocks
- 100 MHz Differential LCD clock
- 96 MHz Differential DOT clock
- 48 MHz USB clocks
- 33 MHz PCI clock
- 27 MHz Video clocks
- Buffered Reference Clock 14.318 MHz
- Low-voltage frequency select input
- I²C support with readback capabilities
- Ideal Lexmark Spread Spectrum profile for maximum electromagnetic interference (EMI) reduction
- 3.3V Power supply
- 64-pin QFN/TSSOP packages

CPU	SRC	PCI	REF	DOT96	USB_48	LCD	27M
x2 / x3	x7/11	x6	x 1	x 1	x 1	x1	x2

Block Diagram

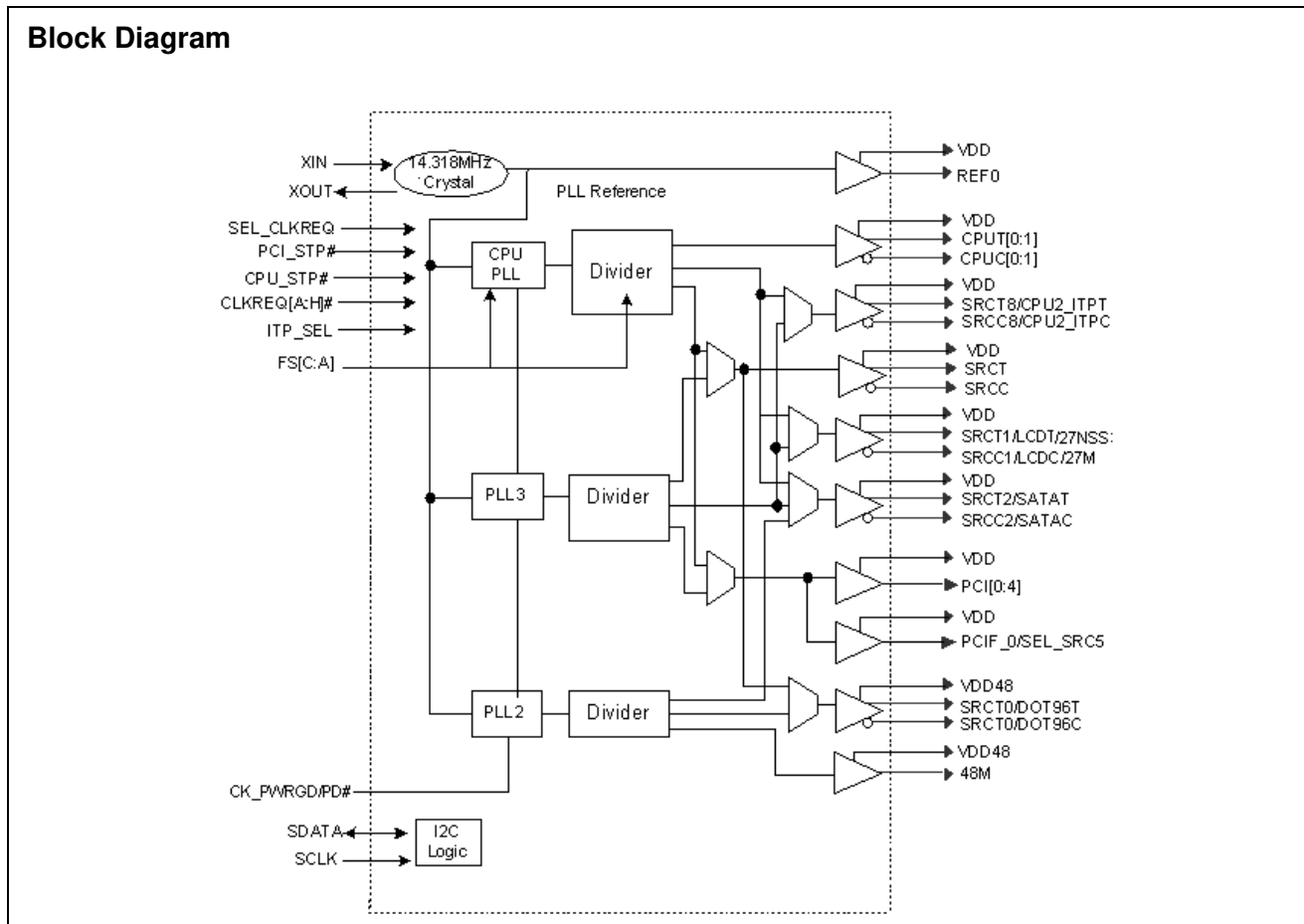

Pin Configuration

64-Pin TSSOP

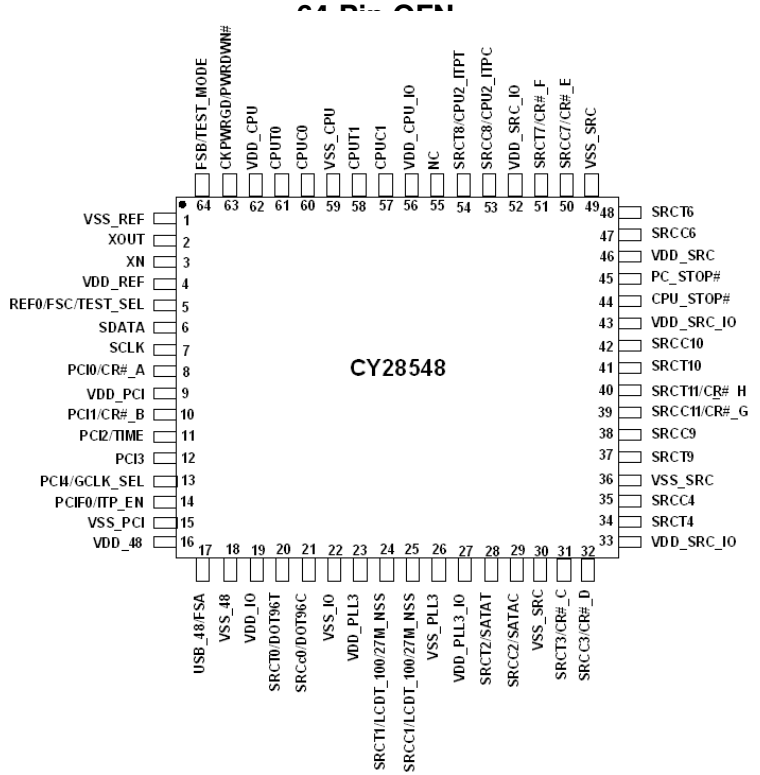
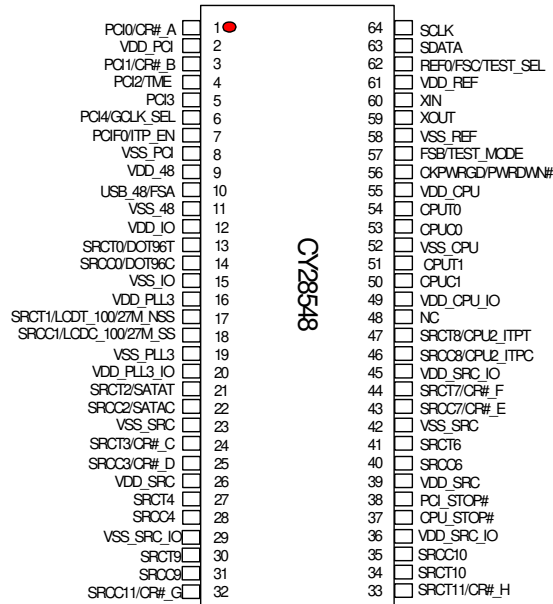

QFN Pin Definitions

Pin No.	Name	Type	Description
1	VSS_REF	GND	Ground for outputs.
2	Xout	O, SE	14.318 MHz Crystal output.
3	Xin	I	14.318 MHz Crystal input.
4	VDD_REF	PWR	3.3V Power supply for outputs and maintains SMBUS registers during power down.
5	REF0 / FSC / TEST_SEL	I/O	Fixed 14.318 clock output/3.3V-tolerant input for CPU frequency selection/ Selects test mode if pulled to V _{IHFS_C} when CK_PWRGD is asserted HIGH. Refer to DC Electrical Specifications table for V _{ILFS_C} , V _{IMFS_C} , V _{IHFS_C} specifications.
6	SDATA	I/O	SMBus compatible SDATA.
7	SCLK	I	SMBus compatible SCLOCK.

QFN Pin Definitions (continued)

Pin No.	Name	Type	Description															
8	PCI0 / CR#_A	I/O, SE	33 MHz Clock/3.3V Clock Request # Input Mappable via I2C to control either SRC 0 or SRC 2. Default PCI0. To configure this pin to serve as a Clock Request pin for either SRC pair 2 or pair 0 using the CR#_A_EN bit located in byte 5 bit 7, first disable PCI output (Hi-z) in byte 2, bit 1. 0 = PCI0 enabled (default) 1 = CR#_A enabled. Byte 5, bit 6 controls whether CR#_A controls SRC0 or SRC2 pair Byte 5, bit 6: 0 = CR#_A controls SRC0 pair (default) 1 = CR#_A controls SRC2 pair															
9	VDD_PCI	PWR	3.3V power supply for PCI PLL															
10	PCI1 / CR#_B	I/O, SE	33 MHz Clock/3.3V Clock Request # Input Mappable via I2C to control either SRC 1 or SRC 4. Default PCI1. To configure this pin to serve as a Clock Request pin for either SRC pair 1 or pair 4 using the CR#_B_EN bit located in byte 5, bit 5, first disable PCI output (Hi-z) in byte 2, bit 1. 0 = PCI1 enabled (default) 1 = CR#_B enabled. Byte 5, bit 4 controls whether CR#_B controls SRC1 or SRC4 pair Byte 5, bit 4: 0 = CR#_B controls SRC1 pair (default) 1 = CR#_B controls SRC4 pair															
11	PCI2 / TME	I/O, SE	33 MHz Clock output/3.3V-tolerance input for enabling Trusted Mode Sampled at CKPWRGD assertion: 0 = Normal mode, 1 = Trusted mode (no overclocking)															
12	PCI3	O, SE	33 MHz Clock output															
13	PCI4 / GCLK_SEL	I/O, SE	33 MHz Clock output/3.3V-tolerant input for selecting graphic clock source on pin 20, 21, 24 and 25 Sampled on CKPWRGD assertion; <table border="1" data-bbox="678 1171 1409 1283"> <thead> <tr> <th>GCLK_SEL</th> <th>Pin 20</th> <th>Pin 21</th> <th>Pin 24</th> <th>Pin 25</th> </tr> </thead> <tbody> <tr> <td>0</td> <td>DOT96T</td> <td>DOT96C</td> <td>SRC1T/LCD_100T</td> <td>SRC1C/LCD_100C</td> </tr> <tr> <td>1</td> <td>SRCT0</td> <td>SRCC0</td> <td>27M_NSS</td> <td>27M_SS</td> </tr> </tbody> </table>	GCLK_SEL	Pin 20	Pin 21	Pin 24	Pin 25	0	DOT96T	DOT96C	SRC1T/LCD_100T	SRC1C/LCD_100C	1	SRCT0	SRCC0	27M_NSS	27M_SS
GCLK_SEL	Pin 20	Pin 21	Pin 24	Pin 25														
0	DOT96T	DOT96C	SRC1T/LCD_100T	SRC1C/LCD_100C														
1	SRCT0	SRCC0	27M_NSS	27M_SS														
14	PCIF0 / ITP_EN	I/O, SE	33 MHz free running clock output/3.3V LVTTTL input to enable SRC8 or CPU2_ITP (sampled on the CKPWRGD assertion) 1 = CPU2_ITP, 0 = SRC8															
15	VSS_PCI	GND	Ground for outputs.															
16	VDD_48	PWR	3.3V power supply for outputs and PLL.															
17	USB_48 / FSA	I/O	Fixed 48 MHz clock output/3.3V-tolerant input for CPU frequency selection Refer to DC Electrical Specifications table for Vil_FS and Vih_FS specifications.															
18	VSS_48	GND	Ground for outputs.															
19	VDD_IO	PWR	3.3V-1.25V power supply for outputs															
20	SRCT0 / DOT96T	O, DIF	True 100 MHz Differential serial reference clocks/Fixed True 96 MHz clock output. Selected via GCLK_SEL at CKPWRGD assertion															
21	SRCC0 / DOT96C	O, DIF	Complementary 100 MHz Differential serial reference clocks/Fixed complement 96 MHz clock output. Selected via GCLK_SEL at CKPWRGD assertion															
22	VSS_IO	GND	Ground for outputs.															
23	VDD_PLL3	PWR	3.3V Power supply for PLL3.															
24	SRCT1 / LCDT_100/27M_NSS	O, DIF, SE	True 100 MHz differential serial reference clock output/True 100 MHz LCD video clock output / Non spread 27-MHz video clock output. Selected via GCLK_SEL at CKPWRGD assertion.															

QFN Pin Definitions (continued)

Pin No.	Name	Type	Description
25	SRCC1 / LCDC_100/27M_SS	O, DIF, SE	Complementary 100 MHz differential serial reference clock output/Complementary 100 MHz LCD video clock output /Spread 27 MHz video clock output. Selected via GCLK_SEL at CKPWRGD assertion.
26	VSS_PLL3	GND	Ground for PLL3.
27	VDD_PLL3_IO	PWR	3.3V-1.25V power supply for outputs.
28	SRCT2 / SATAT	O, DIF	True 100 MHz differential serial reference clock output.
29	SRCC2 / SATAC	O, DIF	Complementary 100 MHz differential serial reference clock output.
30	VSS_SRC	GND	Ground for outputs.
31	SRCT3 / CR#_C	I/O, DIF	True 100 MHz differential serial reference clock output /3.3V Clock Request #_C/D input Selected via CR#_C_EN/CR#_D_EN bit located in byte 5 bit 3and 1. The CR#_C_SEL and CR#_D_SEL bits in byte 5 bit 2 and 0 will select which SRC to stop when asserted
32	SRCC3 / CR#_D	I/O, DIF	Complementary 100 MHz differential serial reference clock output/3.3V Clock Request #_C/D input Selected via CR#_C_EN/CR#_D_EN bit located in byte 5 bit 3and 1. The CR#_C_SEL and CR#_D_SEL bits in byte 5 bit 2 and 0 will select which SRC to stop when asserted
33	VDD_SRC_IO	PWR	3.3V-1.25V Power supply for outputs.
34	SRCT4	O, DIF	True 100 MHz differential serial reference clocks.
35	SRCC4	O, DIF	Complementary 100 MHz differential serial reference clocks.
36	VSS_SRC	GND	Ground for outputs.
37	SRCT9	O, DIF	True 100 MHz differential serial reference clocks.
38	SRCC9	O, DIF	Complementary 100 MHz differential serial reference clocks.
39	SRCC11/ CR#_G	I/O, DIF	True 100 MHz differential serial reference clocks/3.3V CR#_G Input. Selected via CR#_G_EN/CR#_H_EN bit located in byte 6 bit 5 and 4. When selected, CR#_G controls SRC9, CR#_H controls SRC10
40	SRCT11/ CR#_H	I/O, DIF	Complementary 100 MHz Differential serial reference clocks/3.3V CR#_H Input. Selected via CR#_G_EN/CR#_H_EN bit located in byte 6 bit 5 and 4. When selected, CR#_G controls SRC9, CR#_H controls SRC10
41	SRCT10	O, DIF	True 100 MHz Differential serial reference clocks.
42	SRCC10	O, DIF	Complementary 100 MHz Differential serial reference clocks.
43	VDD_SRC_IO	PWR	3.3V-1.25V power supply for outputs.
44	CPU_STOP#	I	3.3V-tolerant input for stopping CPU outputs During direct clock off to M1 mode transition, a serial load of BSEL data is driven on CPU_STOP# and sampled on the rising edge of PCI_STOP#. See <i>Figure 13</i> for more information.
45	PCI_STOP#	I	3.3V-tolerant input for stopping PCI and SRC outputs During direct clock off to M1 mode transition, a serial load of BSEL data is driven on CPU_STOP# and sampled on the rising edge of PCI_STOP#. See <i>Figure 13</i> for more information.
46	VDD_SRC	PWR	3.3V power supply for SRC PLL.
47	SRCC6	O, DIF	Complementary 100 MHz Differential serial reference clocks.
48	SRCT6	O, DIF	True 100 MHz Differential serial reference clocks.
49	VSS_SRC	GND	Ground for outputs.
50	SRCC7/ CR#_E	I/O, DIF	Complementary 100 MHz differential serial reference clocks/3.3V CR#_E Input. Selected via CR#_E_EN/CR#_F_EN bit located in byte 6 bit 7 and 6. When selected, CR#_E controls SRC6, CR#_F controls SRC8

QFN Pin Definitions (continued)

Pin No.	Name	Type	Description
51	SRCT7/ CR#_F	I/O, DIF	True 100 MHz differential serial reference clocks/3.3V CR#_F Input. Selected via CR#_E_EN/CR#_F_EN bit located in byte 6 bit 7 and 6. When selected, CR#_E controls SRC6, CR#_F controls SRC8
52	VDD_SRC_IO	PWR	3.3V-1.25V Power supply for outputs.
53	SRCC8 / CPUC2_ITP	O, DIF	Selectable complementary differential CPU or SRC clock output. ITP_EN = 0 @ CK_PWRGD assertion = SRC8 ITP_EN = 1 @ CK_PWRGD assertion = CPU2
54	SRCT8 / CPUT2_ITP,	O, DIF	Selectable True differential CPU or SRC clock output. ITP_EN = 0 @ CK_PWRGD assertion = SRC8 ITP_EN = 1 @ CK_PWRGD assertion = CPU2
55	NC	NC	No connect.
56	VDD_CPU_IO	PWR	3.3V-1.25V Power supply for outputs.
57	CPUC1	O, DIF	Complementary differential CPU clock outputs. Note that CPU1 is the iAMT clock and is on in that mode.
58	CPUT1	O, DIF	True differential CPU clock outputs. Note that CPU1 is the iAMT clock and is on in that mode.
59	VSS_CPU	GND	Ground for outputs.
60	CPUC0	O, DIF	Complement differential CPU clock outputs.
61	CPUT0	O, DIF	True differential CPU clock outputs.
62	VDD_CPU	PWR	3.3V Power supply for CPU PLL.
63	CKPWRGD / PWRDWN#	I	3.3V LVTTTL input. This pin is a level sensitive strobe used to latch the FS_A, FS_B, FS_C, GLCK_SEL and ITP_EN. After CKPWRGD (active HIGH) assertion, this pin becomes a real-time input for asserting power down (active LOW).
64	FSB / TEST_MODE	I	3.3V-tolerant input for CPU frequency selection / Selects Ref/N or Tri-state when in test mode. 0 = Tri-state, 1 = Ref/N Refer to DC Electrical Specifications table for Vil_FS and Vih_FS specifications.

TSSOP Pin Definitions

Pin No.	Name	Type	Description
1	PCI0 / CR#_A	I/O, SE	33 MHz clock/3.3V Clock Request # Input. Selected via CR#_A_EN bit located in byte 5 bit 7. The CR#_A_SEL bit in byte 5 bit 6 will select to control SRC0 or SRC2 when asserted.
2	VDD_PCI	PWR	3.3V Power supply for PCI PLL.
3	PCI1 / CR#_B	I/O, SE	33 MHz Clock/3.3V Clock Request # Input. Selected via CR#_B_EN bit located in byte 5 bit 5. The CR#_B_SEL bit in byte 5 bit 4 will select to control SRC1 or SRC4 when asserted.
4	PCI2 / TME	I/O, SE	33 MHz clock output / 3.3V-tolerance input for enabling trusted mode Sampled at CKPWRGD assertion: 0 = Normal mode, 1 = Trusted mode (no overclocking)
5	PCI3	O, SE	33 MHz clock output

TSSOP Pin Definitions (continued)

Pin No.	Name	Type	Description															
6	PCI4 / GCLK_SEL	I/O, SE	<p>33 MHz clock output/3.3V-tolerant input for selecting graphic clock source on pin 13, 14, 17 and 18 Sampled on CKPWRGD assertion</p> <table border="1" data-bbox="711 409 1399 514"> <thead> <tr> <th>GCLK_SEL</th> <th>Pin13</th> <th>Pin14</th> <th>Pin17</th> <th>Pin 18</th> </tr> </thead> <tbody> <tr> <td>0</td> <td>DOT96T</td> <td>DOT96C</td> <td>SRC1T/LCD_100T</td> <td>SRC1C/LCD_100C</td> </tr> <tr> <td>1</td> <td>SRCT0</td> <td>SRCC0</td> <td>27M_NSS</td> <td>27M_SS</td> </tr> </tbody> </table>	GCLK_SEL	Pin13	Pin14	Pin17	Pin 18	0	DOT96T	DOT96C	SRC1T/LCD_100T	SRC1C/LCD_100C	1	SRCT0	SRCC0	27M_NSS	27M_SS
GCLK_SEL	Pin13	Pin14	Pin17	Pin 18														
0	DOT96T	DOT96C	SRC1T/LCD_100T	SRC1C/LCD_100C														
1	SRCT0	SRCC0	27M_NSS	27M_SS														
7	PCIF0 / ITP_EN	I/O, SE	<p>33 MHz free running clock output / 3.3V LVTTTL input to enable SRC8 or CPU2_I TP (sampled on the CKPWRGD assertion) 1 = CPU2_I TP, 0 = SRC8</p>															
8	VSS_PCI	GND	Ground for outputs.															
9	VDD_48	PWR	3.3V power supply for outputs and PLL.															
10	USB_48 / FSA	I/O	Fixed 48 MHz clock output / 3.3V-tolerant input for CPU frequency selection Refer to DC Electrical Specifications table for Vil_FS and Vih_FS specifications.															
11	VSS_48	GND	Ground for outputs.															
12	VDD_IO	PWR	3.3V-1.25V power supply for outputs															
13	SRCT0 / DOT96T	O, DIF	True 100 MHz differential serial reference clocks / Fixed True 96 MHz clock output. Selected via GCLK_SEL at CKPWRGD assertion															
14	SRCC0 / DOT96C	O, DIF	Complementary 100 MHz differential serial reference clocks / Fixed Complementary 96 MHz clock output. Selected via GCLK_SEL at CKPWRGD assertion															
15	VSS_IO	GND	Ground for outputs															
16	VDD_PLL3	PWR	3.3V Power supply for PLL3															
17	SRCT1 / LCDT_100/27M_NSS	O, DIF, SE	True 100 MHz differential serial reference clock output / True 100 MHz LCD video clock output / Non spread 27 MHz video clock output. Selected via GCLK_SEL at CKPWRGD assertion															
18	SRCC1 / LCDC_100/27M_SS	O, DIF, SE	Complementary 100 MHz differential serial reference clock output / Complementary 100 MHz LCD video clock output / Spread 27 MHz video clock output. Selected via GCLK_SEL at CKPWRGD assertion															
19	VSS_PLL3	GND	Ground for PLL3.															
20	VDD_PLL3_IO	PWR	3.3V-1.25V power supply for outputs.															
21	SRCT2 / SATAT	O, DIF	True 100 MHz differential serial reference clock output.															
22	SRCC2 / SATAC	O, DIF	Complementary 100 MHz differential serial reference clock output.															
23	VSS_SRC	GND	Ground for outputs.															
24	SRCT3 / CR#_C	I/O, DIF	True 100 MHz differential serial reference clock output / 3.3V CR #_C/D input Selected via CR#_C_EN/CR#_D_EN bit located in byte 5 bit 3 and 1. The CR#_C_SEL and CR#_D_SEL bits in byte 5 bit 2 and 0 will select which SRC to stop when asserted															
25	SRCC3 / CR#_D	I/O, DIF	Complementary 100 MHz differential serial reference clock output / 3.3V CR #_C/D input Selected via CR#_C_EN/CR#_D_EN bit located in byte 5 bit 3 and 1. The CR#_C_SEL and CR#_D_SEL bits in byte 5 bit 2 and 0 will select which SRC to stop when asserted															
26	VDD_SRC_IO	PWR	3.3V-1.25V power supply for outputs.															
27	SRCT4	O, DIF	True 100 MHz differential serial reference clocks.															
28	SRCC4	O, DIF	Complementary 100 MHz differential serial reference clocks.															
29	VSS_SRC	GND	Ground for outputs.															
30	SRCT9	O, DIF	True 100 MHz differential serial reference clocks.															
31	SRCC9	O, DIF	Complementary 100 MHz differential serial reference clocks.															

TSSOP Pin Definitions (continued)

Pin No.	Name	Type	Description
32	SRCC11/ CR#_G	I/O, DIF	Complementary 100 MHz differential serial reference clocks/3.3V CR#_G Input Selected via CR#_G_EN/CR#_H_EN bit located in byte 6 bit 5 and 4. When selected, CR#_G controls SRC9, CR#_H controls SRC10
33	SRCT11/ CR#_H	I/O, DIF	True 100 MHz differential serial reference clocks/3.3V CR#_H Input Selected via CR#_G_EN/CR#_H_EN bit located in byte 6 bit 5 and 4. When selected, CR#_G controls SRC9, CR#_H controls SRC10
34	SRCT10	O, DIF	True 100 MHz differential serial reference clocks.
35	SRCC10	O, DIF	Complementary 100 MHz differential serial reference clocks.
36	VDD_SRC_IO	PWR	3.3V-1.25V Power supply for outputs.
37	CPU_STOP#	I	3.3V-tolerant input for stopping CPU outputs During direct clock off to M1 mode transition, a serial load of BSEL data is driven on CPU_STOP# and sampled on the rising edge of PCI_STOP#. See <i>Figure 13</i> for more information.
38	PCI_STOP#	I	3.3V-tolerant input for stopping PCI and SRC outputs During direct clock off to M1 mode transition, a serial load of BSEL data is driven on CPU_STOP# and sampled on the rising edge of PCI_STOP#. See <i>Figure 13</i> for more information.
39	VDD_SRC	PWR	3.3V Power supply for SRC PLL.
40	SRCC6	O, DIF	Complementary 100 MHz differential serial reference clocks.
41	SRCT6	O, DIF	True 100 MHz differential serial reference clocks.
42	VSS_SRC	GND	Ground for outputs.
43	SRCC7/ CR#_E	I/O, DIF	Complementary 100 MHz differential serial reference clocks/3.3V CR#_E Input. Selected via CR#_E_EN/CR#_F_EN bit located in byte 6 bit 7 and 6. When selected, CR#_E controls SRC6, CR#_F controls SRC8
44	SRCT7/ CR#_F	I/O, DIF	True 100 MHz differential serial reference clocks/3.3V CR#_F Input. Selected via CR#_E_EN/CR#_F_EN bit located in byte 6 bit 7 and 6. When selected, CR#_E controls SRC6, CR#_F controls SRC8
45	VDD_SRC_IO	PWR	3.3V-1.25V power supply for outputs.
46	SRCC8 / CPUC2_ITP	O, DIF	Selectable Complementary differential CPU or SRC clock output. ITP_EN = 0 @ CK_PWRGD assertion = SRC8 ITP_EN = 1 @ CK_PWRGD assertion = CPU2
47	SRCC8 / CPUC2_ITP	O, DIF	Selectable True differential CPU or SRC clock output. ITP_EN = 0 @ CK_PWRGD assertion = SRC8 ITP_EN = 1 @ CK_PWRGD assertion = CPU2
48	NC	NC	No connect.
49	VDD_CPU_IO	PWR	3.3V-1.25V Power supply for outputs.
50	CPUC1	O, DIF	Complementary differential CPU clock outputs. Note that CPU1 is the iAMT clock and is on in that mode.
51	CPUT1	O, DIF	True differential CPU clock outputs. Note that CPU1 is the iAMT clock and is on in that mode.
52	VSS_CPU	GND	Ground for outputs.
53	CPUC0	O, DIF	Complementary differential CPU clock outputs.
54	CPUT0	O, DIF	True differential CPU clock outputs.
55	VDD_CPU	PWR	3.3V Power supply for CPU PLL.
56	CKPWRGD / PWRDWN#	I	3.3V LVTTTL input. This pin is a level sensitive strobe used to latch the FS_A, FS_B, FS_C, GLCK_SEL and ITP_EN. After CKPWRGD (active HIGH) assertion, this pin becomes a real-time input for asserting power down (active LOW).

TSSOP Pin Definitions (continued)

Pin No.	Name	Type	Description
57	FSB / TEST_MODE	I	3.3V-tolerant input for CPU frequency selection / Selects Ref/N or Tri-state when in test mode: 0 = Tri-state, 1 = Ref/N Refer to DC Electrical Specifications table for Vil_FS and Vih_FS specifications.
58	VSS_REF	GND	Ground for outputs.
59	Xout	O, SE	14.318 MHz Crystal output.
60	Xin	I	14.318 MHz Crystal input.
61	VDD_REF	PWR	3.3V Power supply for outputs and also maintains SMBUS registers during power down.
62	REF0 / FSC / TEST_SEL	I/O	Fixed 14.318 clock output / 3.3V-tolerant input for CPU frequency selection / Selects test mode if pulled to VIHFS_C when CK_PWRGD is asserted HIGH. Refer to DC Electrical Specifications table for VILFS_C, VIMFS_C, VIHFS_C specifications.
63	SDATA	I/O	SMBus-compatible SDATA.
64	SCLK	I	SMBus-compatible SCLOCK.

Table 1. Frequency Select Pin (FSA, FSB and FSC)

FSC	FSB	FSA	CPU	SRC	PCIF/PCI	27MHz	REF	DOT96	USB
0	0	0	266 MHz	100 MHz	33 MHz	27 MHz	14.318 MHz	96 MHz	48 MHz
0	0	1	133 MHz	100 MHz	33 MHz	27 MHz	14.318 MHz	96 MHz	48 MHz
0	1	0	200 MHz	100 MHz	33 MHz	27 MHz	14.318 MHz	96 MHz	48 MHz
0	1	1	166 MHz	100 MHz	33 MHz	27 MHz	14.318 MHz	96 MHz	48 MHz
1	0	0	333 MHz	100 MHz	33 MHz	27 MHz	14.318 MHz	96 MHz	48 MHz
1	0	1	100 MHz	100 MHz	33 MHz	27 MHz	14.318 MHz	96 MHz	48 MHz
1	1	0	400 MHz	100 MHz	33 MHz	27 MHz	14.318 MHz	96 MHz	48 MHz
1	1	1	Reserved	Reserved	Reserved	Reserved	Reserved	Reserved	Reserved

Frequency Select Pin (FSA, FSB and FSC)

Apply the appropriate logic levels to FSA, FSB, and FSC inputs before CK-PWRGD assertion to achieve host clock frequency selection. When the clock chip sampled HIGH on CK-PWRGD and indicates that VTT voltage is stable then FSA, FSB, and FSC input values are sampled. This process employs a one-shot functionality and once the CK-PWRGD sampled a valid HIGH, all other FSA, FSB, FSC, and CK-PWRGD transitions are ignored except in test mode

optional. Clock device register changes are normally made at system initialization, if any are required. The interface cannot be used during system operation for power management functions.

Serial Data Interface

To enhance the flexibility and function of the clock synthesizer, a two-signal serial interface is provided. Through the Serial Data Interface, various device functions, such as individual clock output buffers are individually enabled or disabled. The registers associated with the Serial Data Interface initialize to their default setting at power-up. The use of this interface is

Data Protocol

The clock driver serial protocol accepts byte write, byte read, block write, and block read operations from the controller. For block write/read operation, Access the bytes in sequential order from lowest to highest (most significant bit first) with the ability to stop after any complete byte is transferred. For byte write and byte read operations, the system controller can access individually indexed bytes. The offset of the indexed byte is encoded in the command code described in *Table 2*.

The block write and block read protocol is outlined in *Table 3* while *Table 4* outlines byte write and byte read protocol. The slave receiver address is 11010010 (D2h)

Table 2. Command Code Definition

Bit	Description
7	0 = Block read or block write operation, 1 = Byte read or byte write operation
(6:0)	Byte offset for byte read or byte write operation. For block read or block write operations, these bits should be '000000'

Table 3. Block Read and Block Write Protocol

Block Write Protocol		Block Read Protocol	
Bit	Description	Bit	Description
1	Start	1	Start
8:2	Slave address–7 bits	8:2	Slave address–7 bits
9	Write	9	Write
10	Acknowledge from slave	10	Acknowledge from slave
18:11	Command Code–8 bits	18:11	Command Code–8 bits
19	Acknowledge from slave	19	Acknowledge from slave
27:20	Byte Count–8 bits (Skip this step if I ² C_EN bit set)	20	Repeat start
28	Acknowledge from slave	27:21	Slave address–7 bits
36:29	Data byte 1–8 bits	28	Read = 1
37	Acknowledge from slave	29	Acknowledge from slave
45:38	Data byte 2–8 bits	37:30	Byte Count from slave–8 bits
46	Acknowledge from slave	38	Acknowledge
....	Data Byte /Slave Acknowledges	46:39	Data byte 1 from slave–8 bits
....	Data Byte N–8 bits	47	Acknowledge
....	Acknowledge from slave	55:48	Data byte 2 from slave–8 bits
....	Stop	56	Acknowledge
		Data bytes from slave / Acknowledge
		Data Byte N from slave–8 bits
		NOT Acknowledge
		Stop

Table 4. Byte Read and Byte Write Protocol

Byte Write Protocol		Byte Read Protocol	
Bit	Description	Bit	Description
1	Start	1	Start
8:2	Slave address–7 bits	8:2	Slave address–7 bits
9	Write	9	Write
10	Acknowledge from slave	10	Acknowledge from slave
18:11	Command Code–8 bits	18:11	Command Code–8 bits
19	Acknowledge from slave	19	Acknowledge from slave
27:20	Data byte–8 bits	20	Repeated start
28	Acknowledge from slave	27:21	Slave address–7 bits
29	Stop	28	Read
		29	Acknowledge from slave
		37:30	Data from slave–8 bits
		38	NOT Acknowledge
		39	Stop

Control Registers

Byte 0: Control Register 0

Bit	@Pup	Name	Description
7	HW	FS_C	CPU Frequency Select Bit, set by HW
6	HW	FS_B	CPU Frequency Select Bit, set by HW
5	HW	FS_A	CPU Frequency Select Bit, set by HW
4	0	iAMT_EN	Set via SMBus or by combination of PWRDWN, CPU_STP, and PCI_STP 0 = Legacy Mode, 1 = iAMT Enabled
3	0	Reserved	Reserved
2	0	SRC_Main_SEL	Select source for SRC clock 0 = SRC_MAIN = PLL1, <i>PLL3_CFG Table applies</i> 1 = SRC_MAIN = PLL3, <i>PLL3_CFG Table does not apply</i>
1	0	SATA_SEL	Select source of SATA clock 0 = SATA = SRC_MAIN, 1 = SATA = PLL2
0	1	PD_Restore	Save Config. In powerdown 0 = Config. Cleared, 1 = Config. Saved

Byte 1: Control Register 1

Bit	@Pup	Name	Description
7	0	SRC0_SEL	Select for SRC0 or DOT96 0 = SRC0, 1 = DOT96 When GCLK_SEL=0, this bit is 1. When GCLK_SEL=1, this bit is 0
6	0	PLL1_SS_DC	Select for down or center SS 0 = Down spread, 1 = Center spread
5	0	PLL3_SS_DC	Select for down or center SS 0 = Down spread, 1 = Center spread
4	0	PLL3_CFB3	Bit 4:1 only applies when SRC_Main_SEL = 0 See <i>Table 8: PLL3 / SE configuration table</i>
3	0	PLL3_CFB2	
2	0	PLL3_CFB1	
1	1	PLL3_CFB0	
0	1	Reserved	Reserved

Byte 2: Control Register 2

Bit	@Pup	Name	Description
7	1	REF	Output enable for REF 0 = Output Disabled, 1 = Output Enabled
6	1	USB	Output enable for USB 0 = Output Disabled, 1 = Output Enabled
5	1	PCIF0	Output enable for PCIF0 0 = Output Disabled, 1 = Output Enabled
4	1	PCI4	Output enable for PCI4 0 = Output Disabled, 1 = Output Enabled
3	1	PCI3	Output enable for PCI3 0 = Output Disabled, 1 = Output Enabled
2	1	PCI2	Output enable for PCI2 0 = Output Disabled, 1 = Output Enabled
1	1	PCI1	Output enable for PCI1 0 = Output Disabled, 1 = Output Enabled
0	1	PCI0	Output enable for PCI0 0 = Output Disabled, 1 = Output Enabled

Byte 3: Control Register 3

Bit	@Pup	Name	Description
7	1	SRC[T/C]11	Output enable for SRC11 0 = Output Disabled, 1 = Output Enabled
6	1	SRC[T/C]10	Output enable for SRC10 0 = Output Disabled, 1 = Output Enabled
5	1	SRC[T/C]9	Output enable for SRC9 0 = Output Disabled, 1 = Output Enabled
4	1	SRC[T/C]8/CPU2_ITP	Output enable for SRC8 or CPU2_ITP 0 = Output Disabled, 1 = Output Enabled
3	1	SRC[T/C]7	Output enable for SRC7 0 = Output Disabled, 1 = Output Enabled
2	1	SRC[T/C]6	Output enable for SRC6 0 = Output Disabled, 1 = Output Enabled
1	1	Reserved	Reserved
0	1	SRC[T/C]4	Output enable for SRC4 0 = Output Disabled, 1 = Output Enabled

Byte 4: Control Register 4

Bit	@Pup	Name	Description
7	1	SRC[T/C]3	Output enable for SRC3 0 = Output Disabled, 1 = Output Enabled
6	1	SRC[T/C]2/SATA	Output enable for SRC2/SATA 0 = Output Disabled, 1 = Output Enabled
5	1	SRC[T/C]1/LCD_100M[T/C]	Output enable for SRC1/LCD_100M 0 = Output Disabled, 1 = Output Enabled
4	1	SRC[T/C]0/DOT96[T/C]	Output enable for SRC0/DOT96 0 = Output Disabled, 1 = Output Enabled
3	1	CPU[T/C]1	Output enable for CPU1 0 = Output Disabled, 1 = Output Enabled
2	1	CPU[T/C]0	Output enable for CPU0 0 = Output Disabled, 1 = Output Enabled
1	1	PLL1_SS_EN	Enable PLL1s spread modulation, 0 = Spread Disabled, 1 = Spread Enabled
0	1	PLL3_SS_EN	Enable PLL3s spread modulation 0 = Spread Disabled, 1 = Spread Enabled

Byte 5: Control Register 5

Bit	@Pup	Name	Description
7	0	CR#_A_EN	Enable CR#_A (clk req) 0 = Disabled, 1 = Enabled,
6	0	CR#_A_SEL	Set CR#_A → SRC0 or SRC2 0 = CR#_A→SRC0, 1 = CR#_A→SRC2
5	0	CR#_B_EN	Enable CR#_B (clk req) 0 = Disabled, 1 = Enabled,
4	0	CR#_B_SEL	Set CR#_B → SRC1 or SRC4 0 = CR#_B→SRC1, 1 = CR#_B→SRC4
3	0	CR#_C_EN	Enable CR#_C (clk req) 0 = Disabled, 1 = Enabled
2	0	CR#_C_SEL	Set CR#_C → SRC0 or SRC2 0 = CR#_C→SRC0, 1 = CR#_C→SRC2

Byte 5: Control Register 5 (continued)

Bit	@Pup	Name	Description
1	0	CR#_D_EN	Enable CR#_D (clk req) 0 = Disabled, 1 = Enabled
0	0	CR#_D_SEL	Set CR#_D → SRC1 or SRC4 0 = CR#_D→SRC1, 1 = CR#_D→SRC4

Byte 6: Control Register 6

Bit	@Pup	Name	Description
7	0	CR#_E_EN	Enable CR#_E (clk req) → SRC6 0 = Disabled, 1 = Enabled
6	0	CR#_F_EN	Enable CR#_F (clk req) → SRC8 0 = Disabled, 1 = Enabled
5	0	CR#_G_EN	Enable CR#_G (clk req) → SRC9 0 = Disabled, 1 = Enabled
4	0	CR#_H_EN	Enable CR#_H (clk req) → SRC10 0 = Disabled, 1 = Enabled
3	0	Reserved	Reserved
2	0	Reserved	Reserved
1	0	LCD_100_STP_CTRL	If set, LCD_100 stop with PCI_STOP# 0 = Free running, 1 = PCI_STOP# stoppable
0	0	SRC_STP_CTRL	If set, SRCs stop with PCI_STOP# 0 = Free running, 1 = PCI_STOP# stoppable

Byte 7: Vendor ID

Bit	@Pup	Name	Description
7	0	Rev Code Bit 3	Revision Code Bit 3
6	1	Rev Code Bit 2	Revision Code Bit 2
5	1	Rev Code Bit 1	Revision Code Bit 1
4	0	Rev Code Bit 0	Revision Code Bit 0
3	1	Vendor ID bit 3	Vendor ID Bit 3
2	0	Vendor ID bit 2	Vendor ID Bit 2
1	0	Vendor ID bit 1	Vendor ID Bit 1
0	0	Vendor ID bit 0	Vendor ID Bit 0

Byte 8: Control Register 8

Bit	@Pup	Name	Description
7	1	Device_ID3	0000 = CK505 Yellow Cover Device, 56-pin TSSOP
6	0	Device_ID2	0001 = CK505 Yellow Cover Device, 64-pin TSSOP
5	0	Device_ID1	0010 = CK505 Yellow Cover Device, 48-pin QFN (Reserved)
4	1	Device_ID0	0011 = CK505 Yellow Cover Device, 56-pin QFN (Reserved) 0100 = CK505 Yellow Cover Device, 64-pin QFN 0101 = CK505 Yellow Cover Device, 72-pin QFN (Reserved) 0110 = CK505 Yellow Cover Device, 48-pin SSOP (Reserved) 0111 = CK505 Yellow Cover Device, 48-pin SSOP (Reserved) 1000 = Reserved 1001 = CY28548 1010 = Reserved 1011 = Reserved 1100 = Reserved 1101 = Reserved 1110 = Reserved 1111 = Reserved
3	0	Reserved	Reserved
2	0	Reserved	Reserved
1	1	27M_NSS_OE	Output enable for 27M_NSS 0 = Output Disabled, 1 = Output Enabled
0	1	27M_SS_OE	Output enable for 27M_SS 0 = Output Disabled, 1 = Output Enabled

Byte 9: Control Register 9

Bit	@Pup	Name	Description
7	0	PCIF_0_with PCI_STOP#	Allows control of PCIF_0 with assertion of PCI_STOP# 0 = Free running PCIF, 1 = Stopped with PCI_STOP#
6	HW	TME_STRAP	Trusted mode enable strap status 0 = Normal, 1 = No overclocking
5	1	REF drive strength	REF drive strength 0 = Low 1x, 1 = High 2x
4	0	TEST_MODE_SEL	Mode select either REF/N or tri-state 0 = All output tri-state, 1 = All output REF/N
3	0	TEST_MODE_ENTRY	Allow entry into test mode 0 = Normal operation, 1 = Enter test mode
2	1	12C_VOUT<2>	12C_VOUT[2,1,0]
1	0	12C_VOUT<1>	000 = 0.63V 001 = 0.71V
0	1	12C_VOUT<0>	010 = 0.77V 011 = 0.82V 100 = 0.86V 101 = 0.90V (default) 110 = 0.93V 111 = unused

Byte 10: Control Register 10

Bit	@Pup	Name	Description
7	HW	GCLK_SEL latch	Readback of GCLK_SEL latch 0 = DOT96/LCD_100, 1 = SRC0/27 MHz
6	1	PLL3_EN	PLL3 power down 0 = Power down, 1 = Power up

Byte 10: Control Register 10 (continued)

Bit	@Pup	Name	Description
5	1	PLL2_EN	PLL2 power down 0 = Power down, 1 = Power up
4	1	SRC_DIV_EN	SRC divider disable 0 = Disabled, 1 = Enabled
3	1	PCI_DIV_EN	PCI divider disable 0 = Disabled, 1 = Enabled
2	1	CPU_DIV_EN	CPU divider disable 0 = Disabled, 1 = Enabled
1	1	CPU1 Stop Enable	Enable CPU_STOP# control of CPU1 0 = Free running, 1= Stoppable
0	1	CPU0 Stop Enable	Enable CPU_STOP# control of CPU0 0 = Free running, 1= Stoppable

Byte 11: Control Register 11

Bit	@Pup	Name	Description
7	0	Reserved	Reserved
6	0	Reserved	Reserved
5	0	Reserved	Reserved
4	0	Reserved	Reserved
3	0	Reserved	Reserved
2	0	Reserved	Reserved
1	0	Reserved	Reserved
0	0	Reserved	Reserved

Byte 12: Byte Count

Bit	@Pup	Name	Description
7	0	Reserved	Reserved
6	0	Reserved	Reserved
5	0	BC5	Byte count
4	0	BC4	Byte count
3	1	BC3	Byte count
2	1	BC2	Byte count
1	0	BC1	Byte count
0	1	BC0	Byte count

Byte 13: Control Register 13

Bit	@Pup	Name	Description
7	1	USB drive strength	USB drive strength 0 = Low, 1= High
6	1	PCI/ PCIF drive strength	PCI drive strength 0 = Low, 1 = High
5	0	PLL1_Spread	Select percentage of spread for PLL1 0 = 0.5%, 1=1%
4	1	SATA_SS_EN	Enable SATA spread modulation, 0 = Spread Disabled, 1 = Spread Enabled
3	1	CPU[T/C]2	Allow control of CPU2 with assertion of CPU_STOP# 0 = Free running, 1 = Stopped with CPU_STOP#

Byte 13: Control Register 13 (continued)

Bit	@Pup	Name	Description
2	1	SE1/SE2 drive strength 1 of 2	SE1 and SE2 Drive Strength Setting 1 of 2 (See Byte 0 = Low, 1= High)
1	0	Reserved	Reserved
0	1	SW_PCI	SW PCI_STP# Function 0 = SW PCI_STP assert, 1 = SW PCI_STP deassert When this bit is set to 0, all STOPPABLE PCI, PCIF and SRC outputs are stopped in a synchronous manner with no short pulses. When this bit is set to 1, all STOPPED PCI, PCIF and SRC outputs are resumed in a synchronous manner with no short pulses.

Byte 14: Control Register 14

Bit	@Pup	Name	Description
7	0	CPU_DAF_N7	If Prog_CPU_EN is set, the values programmed in CPU_DAF_N[8:0] and CPU_DAF_M[6:0] are used to determine the CPU output frequency.
6	0	CPU_DAF_N6	
5	0	CPU_DAF_N5	
4	0	CPU_DAF_N4	
3	0	CPU_DAF_N3	
2	0	CPU_DAF_N2	
1	0	CPU_DAF_N1	
0	0	CPU_DAF_N0	

Byte 15: Control Register 15

Bit	@Pup	Name	Description
7	0	CPU_DAF_N8	See Byte 14 for description
6	0	CPU_DAF_M6	If Prog_CPU_EN is set, the values programmed in CPU_DAF_N[8:0] and CPU_DAF_M[6:0] are used to determine the CPU output frequency.
5	0	CPU_DAF_M5	
4	0	CPU_DAF_M4	
3	0	CPU_DAF_M3	
2	0	CPU_DAF_M2	
1	0	CPU_DAF_M1	
0	0	CPU_DAF_M0	

Byte 16: Control Register 16

Bit	@Pup	Name	Description
7	0	PCI-E_N7	PCI-E Dial-A-Frequency [®] Bit N7
6	0	PCI-E_N6	PCI-E Dial-A-Frequency Bit N6
5	0	PCI-E_N5	PCI-E Dial-A-Frequency Bit N5
4	0	PCI-E_N4	PCI-E Dial-A-Frequency Bit N4
3	0	PCI-E_N3	PCI-E Dial-A-Frequency Bit N3
2	0	PCI-E_N2	PCI-E Dial-A-Frequency Bit N2
1	0	PCI-E_N1	PCI-E Dial-A-Frequency Bit N1
0	0	PCI-E_N0	PCI-E Dial-A-Frequency Bit N0

Byte 17: Control Register 17

Bit	@Pup	Name	Description
-----	------	------	-------------

Byte 17: Control Register 17 (continued)

7	0	SMSW_EN	Enable Smooth Switching 0 = Disabled, 1 = Enabled
6	0	SMSW_SEL	Smooth switch select 0 = CPU_PLL, 1 = SRC_PLL
5	0	SE1/SE2 drive strength 2 of 2	SE1 and SE2 drive strength Setting 2 of 2
4	0	Prog_PCI-E_EN	Programmable PCI-E frequency enable 0 = Disabled, 1 = Enabled
3	0	Prog_CPU_EN	Programmable CPU frequency enable 0 = Disabled, 1 = Enabled
2	0	REF drive strength 2 of 2	REFdrive strength strength Setting 2 of 2
1	0	USB drive strength 2 of 2	USB drive strength strength Setting 2 of 2
0	0	PCI/ PCIF drive strength 2of 2	PCI drive strength strength Setting 2 of 2

Table 5. Crystal Recommendations

Frequency (Fund)	Cut	Loading	Load Cap	Drive (max.)	Shunt Cap (max.)	Motional (max.)	Tolerance (max.)	Stability (max.)	Aging (max.)
14.31818 MHz	AT	Parallel	20 pF	0.1 mW	5 pF	0.016 pF	35 ppm	30 ppm	5 ppm

The CY28548 requires a Parallel Resonance Crystal. Substituting a series resonance crystal causes the CY28548 to operate at the wrong frequency and violates the ppm specification. For most applications there is a 300-ppm frequency shift between series and parallel crystals due to incorrect loading

crystal loading correctly. Again, the capacitance on each side is in series with the crystal. The total capacitance on both side is twice the specified crystal load capacitance (CL). Trim capacitors are calculated to provide equal capacitive loading on both sides.

Crystal Loading

Crystal loading plays a critical role in achieving low ppm performance. To realize low ppm performance, use the total capacitance the crystal sees to calculate the appropriate capacitive loading (CL).

Figure 1 shows a typical crystal configuration using the two trim capacitors. It is important that the trim capacitors are in series with the crystal. It is not true that load capacitors are in parallel with the crystal and are approximately equal to the load capacitance of the crystal.

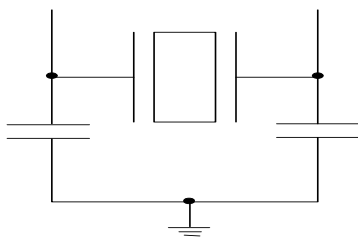

Figure 1. Crystal Capacitive Clarification

Calculating Load Capacitors

In addition to the standard external trim capacitors, consider the trace capacitance and pin capacitance to calculate the

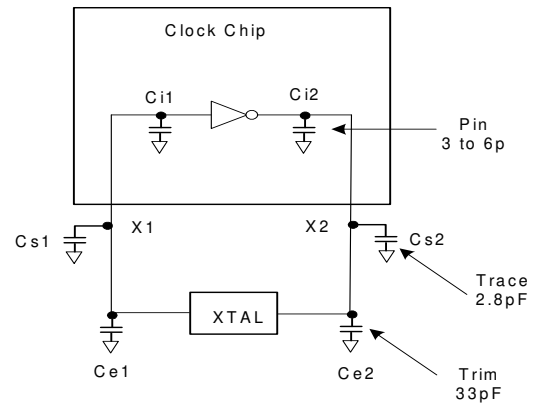

Figure 2. Crystal Loading Example

Use the following formulas to calculate the trim capacitor values for Ce1 and Ce2.

Load Capacitance (each side)

$$C_e = 2 * CL - (C_s + C_i)$$

Total Capacitance (as seen by the crystal)

$$C_{Le} = \frac{1}{\left(\frac{1}{C_{e1} + C_{s1} + C_{i1}} + \frac{1}{C_{e2} + C_{s2} + C_{i2}} \right)}$$

CL	Crystal load capacitance
CLe	Actual loading seen by crystal using standard value trim capacitors
Ce	External trim capacitors
Cs	Stray capacitance (terraced)
Ci	Internal capacitance (lead frame, bond wires, etc.)

Dial-A-Frequency® (CPU and PCIEX)

This feature allows the user to over-clock their system by slowly stepping up the CPU or SRC frequency. When the programmable output frequency feature is enabled, the CPU and SRC frequencies are determined by the following equation:

$$F_{cpu} = G * N/M \text{ or } F_{cpu} = G2 * N, \text{ where } G2 = G / M.$$

- “N” and “M” are the values programmed in Programmable Frequency Select N-Value Register and M-Value Register, respectively.
- “G” stands for the PLL Gear Constant, which is determined by the programmed value of FS[E:A]. See *Table 1, Frequency Select Table* for the Gear Constant for each Frequency selection. The PCI Express only allows user control of the N register, the M value is fixed and documented in *Table 1, Frequency Select Table*.

In this mode, the user writes the desired N and M values into the DAF I2C registers. The user cannot change only the M value and must change both the M and the N values at the same time, if they require a change to the M value. The user may change only the N value.

Associated Register Bits

- *CPU_DAF Enable* – This bit enables CPU DAF mode. By default, it is not set. When set, the operating frequency is determined by the values entered into the CPU_DAF_N register. Note that the CPU_DAF_N and M register must contain valid values before CPU_DAF is set. Default = 0, (No DAF).
- *CPU_DAF_N* – There are nine bits (for 512 values) to linearly change the CPU frequency (limited by VCO range). Default = 0, (0000). The allowable values for N are detailed in *Table 1, Frequency Select Table*.
- *CPU DAF M* – There are 7 bits (for 128 values) to linearly change the CPU frequency (limited by VCO range). Default = 0, the allowable values for M are detailed in *Table 1, Frequency Select Table*.
- *SRC_DAF Enable* – This bit enables SRC DAF mode. By default, it is not set. When set, the operating frequency is determined by the values entered into the SRC_DAF_N register. Note that the SRC_DAF_N register must contain valid values before SRC_DAF is set. Default = 0, (No DAF).
- *SRC_DAF_N* – There are nine bits (for 512 values) to linearly change the CPU frequency (limited by VCO range). Default = 0, (0000). The allowable values for N are detailed in *Table 1, Frequency Select Table*.

Smooth Switching

The device contains one smooth switch circuit that is shared by the CPU PLL and SRC PLL. The smooth switch circuit ensures that when the output frequency changes by overclocking, the transition from the old frequency to the new frequency is a slow, smooth transition containing no glitches. The rate of change of output frequency when using the smooth switch circuit is less than 1 MHz/0.667 μs. The frequency overshoot and undershoot is less than 2%.

The Smooth Switch circuit assigns auto or manual. In Auto mode, clock generator assigns smooth switch automatically when the PLL does overclocking. For manual mode, assign the smooth switch circuit to PLL via Smbus. By default the smooth switch circuit is set to auto mode. PLL can be over-clocked when it does not have control of the smooth switch circuit but it is not guaranteed to transition to the new frequency without large frequency glitches.

Do not enable over-clocking and change the N values of both PLLs in the same SMBUS block write and use smooth switch mechanism on spread spectrum on/off.

PD_RESTORE

If a ‘0’ is set for Byte 0 bit 0 then, upon assertion of PWRDWN# LOW, the CY28548 initiates a full reset. The result of this is that the clock chip emulates a cold power on start and goes to the “Latches Open” state. If the PD_RESTORE bit is set to a ‘1’ then the configuration is stored upon PWRDWN# asserted LOW. Note that if the iAMT bit, Byte 0 bit 3, is set to a ‘1’ then the PD_RESTORE bit must be ignored. In other words, in Intel iAMT mode, PWRDWN# reset is not allowed.

PWRDWN# (Power down) Clarification

The CKPWRGD/PWRDWN# pin is a dual-function pin. During initial power up, the pin functions as CKPWRGD. Once CKPWRGD has been sampled HIGH by the clock chip, the pin assumes PD# functionality. The PD# pin is an asynchronous active LOW input used to shut off all clocks cleanly before shutting off power to the device. This signal is synchronized internally to the device before powering down the clock synthesizer. PD# is also an asynchronous input for powering up the system. When PD# is asserted LOW, clocks are driven to a LOW value and held before turning off the VCOs and the crystal oscillator.

PWRDWN# (Power down) Assertion

When PD is sampled HIGH by two consecutive rising edges of CPUC, all single-ended outputs will be held LOW on their next HIGH-to-LOW transition and differential clocks must held LOW. When PD mode is desired as the initial power on state, PD must be asserted HIGH in less than 10 μs after asserting CKPWRGD.

PWRDWN# Deassertion

The power up latency is less than 1.8 ms. This is the time from the deassertion of the PD# pin or the ramping of the power supply until the time that stable clocks are generated from the clock chip. All differential outputs stopped in a three-state condition, resulting from power down are driven high in less than 300 μs of PD# deassertion to a voltage greater than 200 mV. After the clock chip’s internal PLL is powered up and locked, all outputs are enabled within a few clock cycles of

each clock. *Figure 4* is an example showing the relationship of clocks coming up.

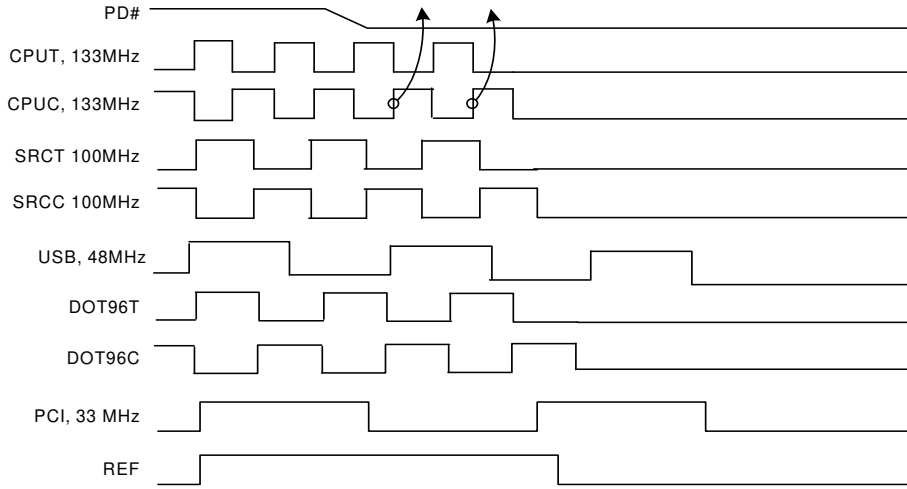

Figure 3. Power down Assertion Timing Waveform

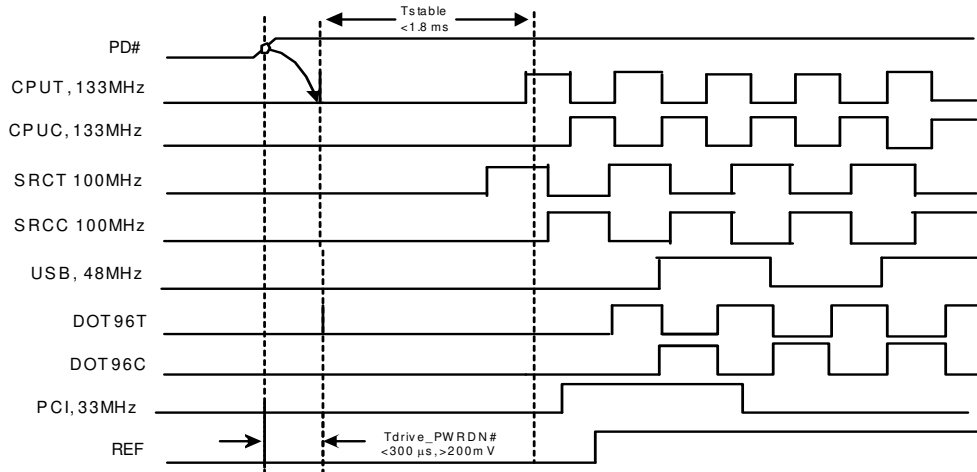

Figure 4. Power down Deassertion Timing Waveform

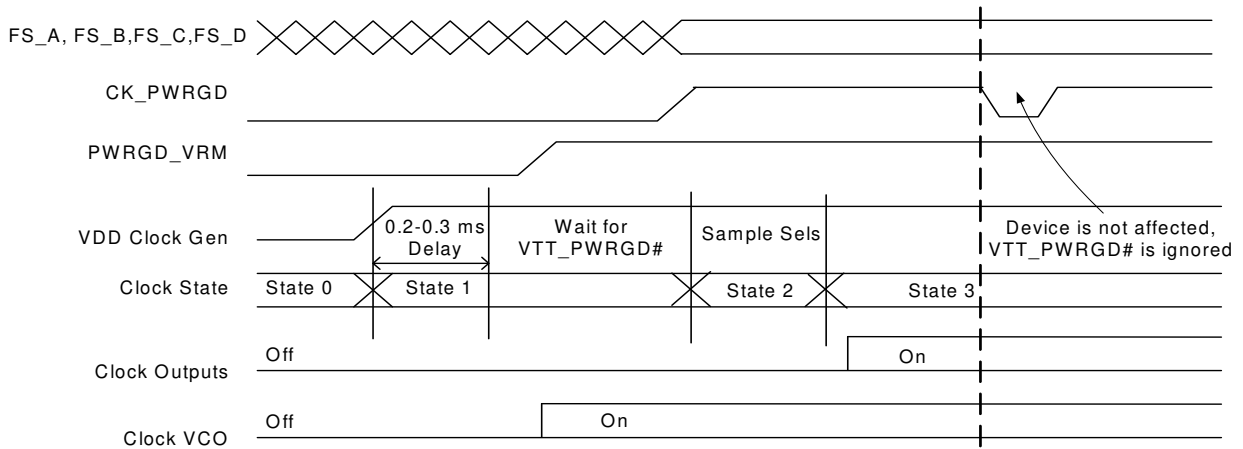

Figure 5. CK_PWRGD Timing Diagram

CPU_STP# Assertion

The CPU_STP# signal is an active LOW input used for synchronous stopping and starting the CPU output clocks while the rest of the clock generator continues to function. When the CPU_STP# pin is asserted, all CPU outputs that are set with the SMBus configuration to be stoppable are stopped within two to six CPU clock periods after sampled by two rising edges of the internal CPUC clock. The final states of the stopped CPU signals are CPUT = HIGH and CPUC = LOW.

CPU_STP# Deassertion

The deassertion of the CPU_STP# signal causes all stopped CPU outputs to resume normal operation in a synchronous manner. No short or stretched clock pulses are produced when the clock resumes. The maximum latency from the deassertion to active outputs is no more than two CPU clock cycles.

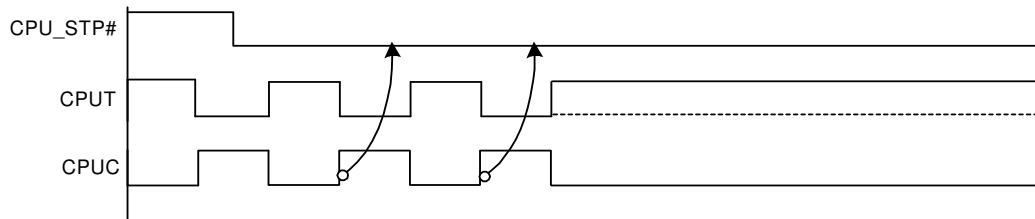

Figure 6. CPU_STP# Assertion Waveform

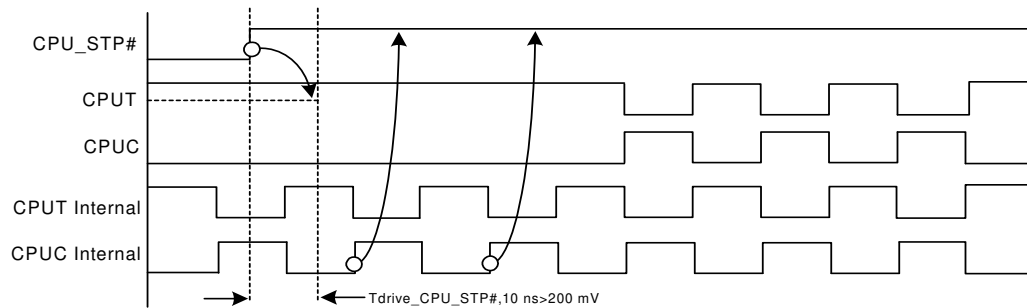

Figure 7. CPU_STP# Deassertion Waveform

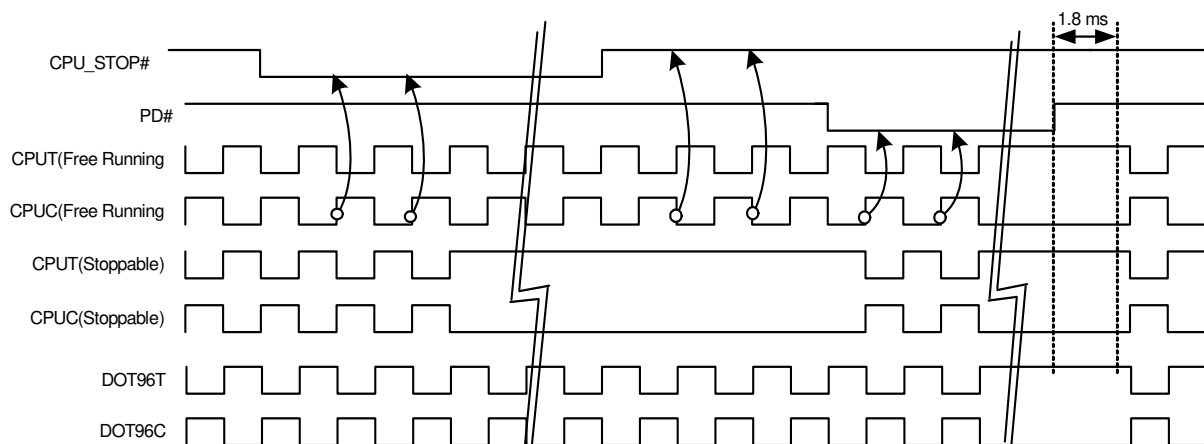

Figure 8. CPU_STP# = Driven, CPU_PD = Driven, DOT_PD = Driven

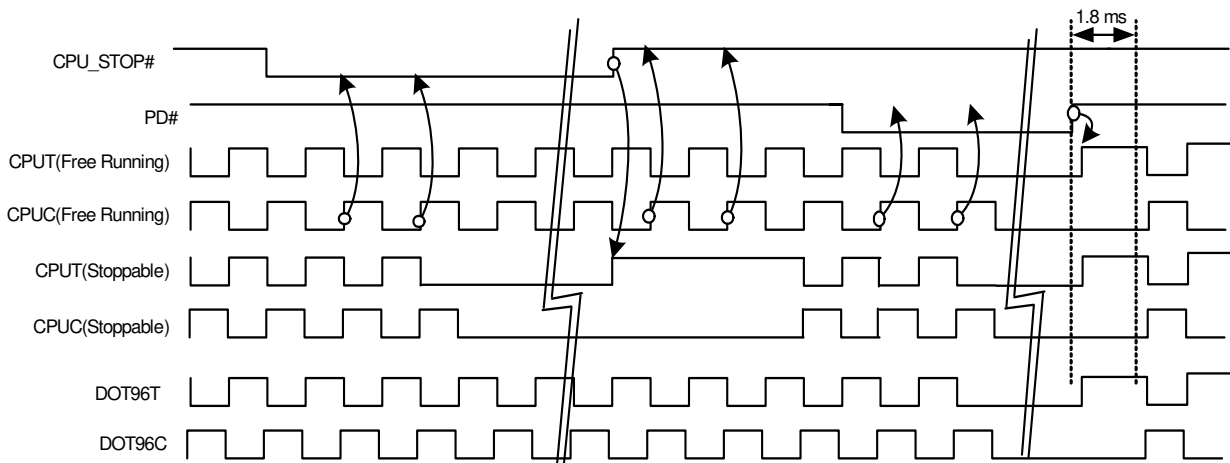

Figure 9. CPU_STP# = Tri-state, CPU_PD = Tri-state, DOT_PD = Tri-state

PCI_STP# Assertion

The PCI_STP# signal is an active LOW input used for synchronously stopping and starting the PCI outputs while the rest of the clock generator continues to function. The set-up time for capturing PCI_STP# going LOW is 10 ns (t_{SU}). (See Figure 10.) The PCIF clocks are affected by this pin if their corresponding control bit in the SMBus register is set to allow them to be free running.

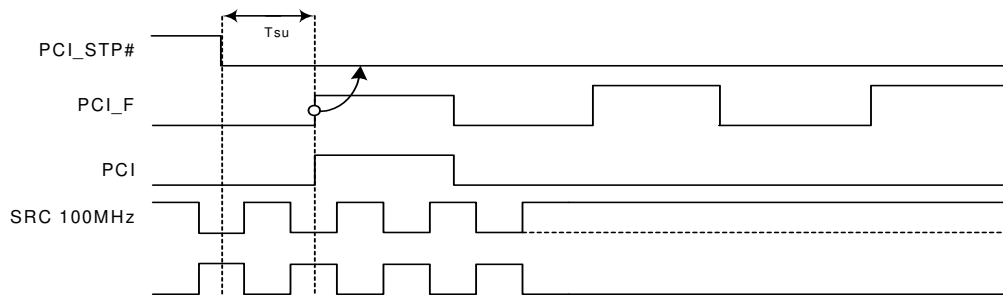

Figure 10. PCI_STP# Assertion Waveform

PCI_STP# Deassertion

The deassertion of the PCI_STP# signal causes all PCI and stoppable PCIF clocks to resume running in a synchronous manner within two PCI clock periods, after PCI_STP# transitions to a HIGH level.

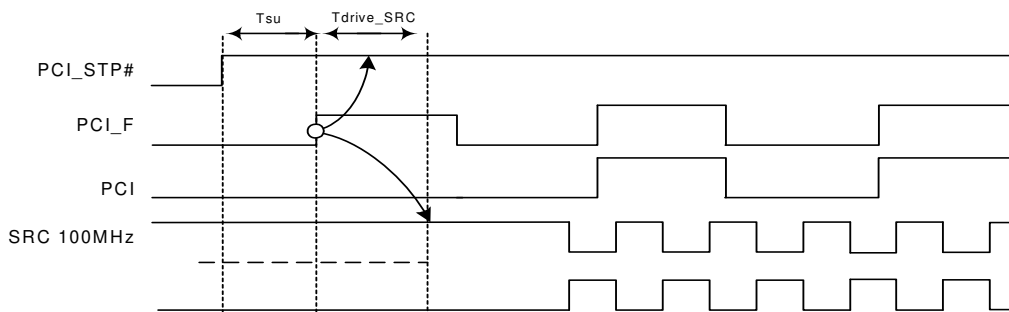

Figure 11. PCI_STP# Deassertion Waveform

Table 6. Output Driver Status during PCI-STOP# and CPU-STOP#

		PCI_STOP# Asserted	CPU_STOP# Asserted	SMBus OE Disabled
Single-ended Clocks	Stoppable	Driven low	Running	Driven low
	Non stoppable	Running	Running	
Differential Clocks	Stoppable	Clock driven high	Clock driven high	Clock driven Low or 20K pulldown
		Clock# driven low	Clock# driven low	
	Non stoppable	Running	Running	

Table 7. Output Driver Status

	All Single-ended Clocks		All Differential Clocks except CPU1		CPU1	
	w/o Strap	w/ Strap	Clock	Clock#	Clock	Clock#
Latches Open State	Low	Hi-z	Low or 20K pulldown	Low	Low or 20K pulldown	Low
Powerdown	Low	Hi-z	Low or 20K pulldown	Low	Low or 20K pulldown	Low
M1	Low	Hi-z	Low or 20K pulldown	Low	Running	Running

Table 8. PLL3/SE Configuration Table

GCLK_SEL	B1b4	B1b3	B1b2	B1b1	Pin 27 (17) MHz	Pin 25 (18) MHz	Spread (%)	Comment
0	0	0	0	0	PLL3 Disabled			
0	0	0	0	1	100	100	0.5	SRC1 from SRC_Main
0	0	0	1	0	100	100	0.5	LCD_100 from PLL3
0	0	0	1	1	100	100	1	LCD_100 from PLL3
0	0	1	0	0	100	100	1.5	LCD_100 from PLL3
0	0	1	0	1	100	100	2	LCD_100 from PLL3
0	0	1	1	0	N/A	N/A	N/A	N/A
0	0	1	1	1	N/A	N/A	N/A	N/A
0	1	0	0	0	N/A	N/A	N/A	N/A
0	1	0	0	1	N/A	N/A	N/A	N/A
0	1	0	1	0	N/A	N/A	N/A	N/A
0	1	0	1	1	N/A	N/A	N/A	N/A
0	1	1	0	0	N/A	N/A	none	N/A
0	1	1	0	1	N/A	N/A	N/A	N/A
0	1	1	1	0	N/A	N/A	N/A	N/A
0	1	1	1	1	N/A	N/A	N/A	N/A
1	0	0	0	0	N/A	N/A	N/A	
1	0	0	0	1	27M_NSS	27M_NSS	0.5	27M_NSS from PLL3
1	0	0	1	0	27M_NSS	27M_NSS	0.5	27M_NSS from PLL3
1	0	0	1	1	27M_NSS	27M_NSS	1	27M_NSS from PLL3
1	0	1	0	0	27M_NSS	27M_NSS	1.5	27M_NSS from PLL3
1	0	1	0	1	27M_NSS	27M_NSS	2	27M_NSS from PLL3
1	0	1	1	0	N/A	N/A	N/A	
1	0	1	1	1	N/A	N/A	N/A	
1	1	0	0	0	N/A	N/A	N/A	
1	1	0	0	1	N/A	N/A	N/A	
1	1	0	1	0	N/A	N/A	N/A	
1	1	0	1	1	N/A	N/A	N/A	
1	1	1	0	0	N/A	N/A	N/A	

Table 8. PLL3/SE Configuration Table (continued)

GCLK_SEL	B1b4	B1b3	B1b2	B1b1	Pin 27 (17) MHz	Pin 25 (18) MHz	Spread (%)	Comment
1	1	1	0	1	N/A	N/A	N/A	

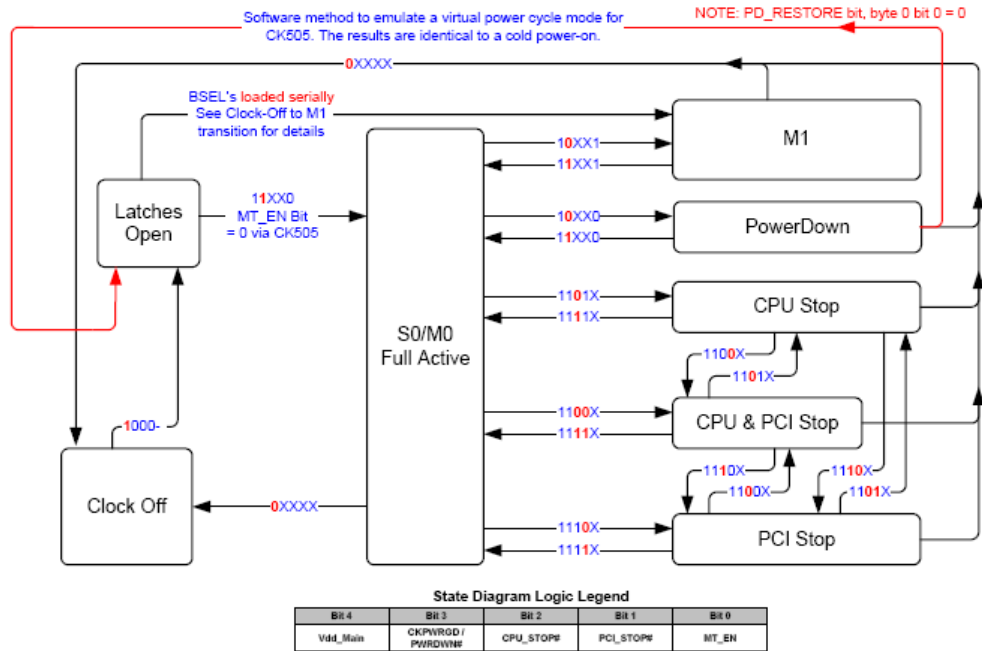

Figure 12. Clock Generator Power up/Run State Diagram

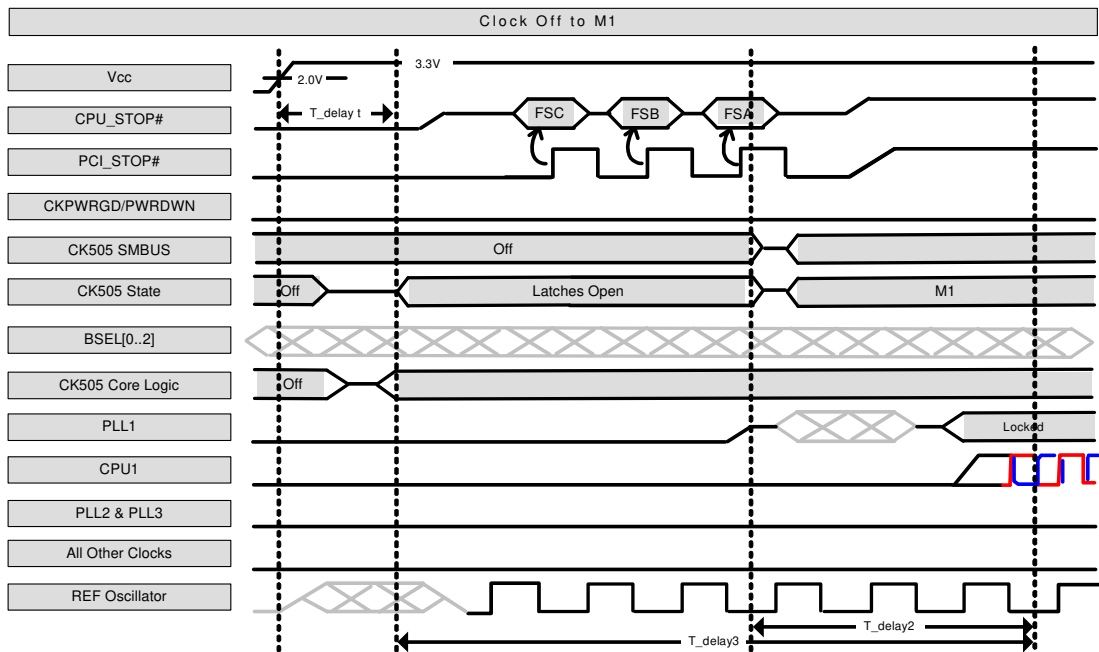

Figure 13. BSEL Serial Latching

Absolute Maximum Conditions

Parameter	Description	Condition	Min.	Max.	Unit
V _{DD}	Core Supply Voltage		–	4.6	V
V _{DD_A}	Analog Supply Voltage		–	4.6	V
V _{DD_IO}	IO Supply Voltage			1.5	V
V _{IN}	Input Voltage	Relative to V _{SS}	–0.5	4.6	V _{DC}
T _S	Temperature, Storage	Non-functional	–65	150	°C
T _A	Temperature, Operating Ambient	Functional	0	85	°C
T _J	Temperature, Junction	Functional	–	150	°C
∅ _{JC}	Dissipation, Junction to Case	Mil-STD-883E Method 1012.1	–	20	°C/W
∅ _{JA}	Dissipation, Junction to Ambient	JEDEC (JESD 51)	–	60	°C/W
ESD _{HBM}	ESD Protection (Human Body Model)	MIL-STD-883, Method 3015	2000	–	V
UL-94	Flammability Rating	At 1/8 in.	V–0		
MSL	Moisture Sensitivity Level		1		

Multiple Supplies: The Voltage on any input or I/O pin cannot exceed the power pin during power-up. Power supply sequencing is NOT required.

DC Electrical Specifications

Parameter	Description	Condition	Min.	Max.	Unit
V _{DD core}	3.3V Operating Voltage	3.3 ± 5%	3.135	3.465	V
V _{IH}	3.3V Input High Voltage (SE)		2.0	V _{DD} + 0.3	V
V _{IL}	3.3V Input Low Voltage (SE)		V _{SS} – 0.3	0.8	V
V _{IHI2C}	Input High Voltage	SDATA, SCLK	2.2	–	V
V _{ILI2C}	Input Low Voltage	SDATA, SCLK	–	1.0	V
V _{IH_FS}	FS_[A,B] Input High Voltage		0.7	1.5	V
V _{IL_FS}	FS_[A,B] Input Low Voltage		V _{SS} – 0.3	0.35	V
V _{IHFS_C_TEST}	FS_C Input High Voltage		2	V _{DD} + 0.3	V
V _{IMFS_C_NORMAL}	FS_C Input Middle Voltage		0.7	1.5	V
V _{ILFS_C_NORMAL}	FS_C Input Low Voltage		V _{SS} – 0.3	0.35	V
I _{IH}	Input High Leakage Current	Except internal pull-down resistors, 0 < V _{IN} < V _{DD}	–	5	μA
I _{IL}	Input Low Leakage Current	Except internal pull-up resistors, 0 < V _{IN} < V _{DD}	–5	–	μA
V _{OH}	3.3V Output High Voltage (SE)	I _{OH} = –1 mA	2.4	–	V
V _{OL}	3.3V Output Low Voltage (SE)	I _{OL} = 1 mA	–	0.4	V
V _{DD IO}	Low Voltage IO Supply Voltage		0.72	0.88	
V _{OH}	3.3V Input High Voltage (DIFF)		0.70	0.90	V
V _{OL}	3.3V Input Low Voltage (DIFF)			0.40	V
I _{OZ}	High-impedance Output Current		–10	10	μA
C _{IN}	Input Pin Capacitance		1.5	5	pF
C _{OUT}	Output Pin Capacitance			6	pF
L _{IN}	Pin Inductance		–	7	nH
V _{XIH}	Xin High Voltage		0.7V _{DD}	V _{DD}	V
V _{XIL}	Xin Low Voltage		0	0.3V _{DD}	V
I _{DD3.3V}	Dynamic Supply Current		–	250	mA

AC Electrical Specifications

Parameter	Description	Condition	Min.	Max.	Unit
Crystal					
T _{DC}	XIN Duty Cycle	The device operates reliably with input duty cycles up to 30/70 but the REF clock duty cycle will not be within specification	47.5	52.5	%
T _{PERIOD}	XIN Period	When XIN is driven from an external clock source	69.841	71.0	ns
T _R /T _F	XIN Rise and Fall Times	Measured between 0.3V _{DD} and 0.7V _{DD}	–	10.0	ns
T _{CCJ}	XIN Cycle to Cycle Jitter	As an average over 1-μs duration	–	500	ps
L _{ACC}	Long-term Accuracy		–	300	ppm
CPU at 0.7V					
T _{DC}	CPUT and CPUC Duty Cycle	Measured at 0V differential at 0.1s	45	55	%
T _{PERIOD}	100 MHz CPUT and CPUC Period	Measured at 0V differential at 0.1s	9.99900	10.0100	ns
T _{PERIOD}	133 MHz CPUT and CPUC Period	Measured at 0V differential at 0.1s	7.49925	7.50075	ns
T _{PERIOD}	166 MHz CPUT and CPUC Period	Measured at 0V differential at 0.1s	5.99940	6.00060	ns
T _{PERIOD}	200 MHz CPUT and CPUC Period	Measured at 0V differential at 0.1s	4.99950	5.00050	ns
T _{PERIOD}	266 MHz CPUT and CPUC Period	Measured at 0V differential at 0.1s	3.74963	3.75038	ns
T _{PERIOD}	333 MHz CPUT and CPUC Period	Measured at 0V differential at 0.1s	2.99970	3.00030	ns
T _{PERIOD}	400 MHz CPUT and CPUC Period	Measured at 0V differential at 0.1s	2.49975	2.50025	ns
T _{PERIODSS}	100 MHz CPUT and CPUC Period, SSC	Measured at 0V differential at 0.1s	10.02406	10.02607	ns
T _{PERIODSS}	133 MHz CPUT and CPUC Period, SSC	Measured at 0V differential at 0.1s	7.51804	7.51955	ns
T _{PERIODSS}	166 MHz CPUT and CPUC Period, SSC	Measured at 0V differential at 0.1s	6.01444	6.01564	ns
T _{PERIODSS}	200 MHz CPUT and CPUC Period, SSC	Measured at 0V differential at 0.1s	5.01203	5.01303	ns
T _{PERIODSS}	266 MHz CPUT and CPUC Period, SSC	Measured at 0V differential at 0.1s	3.75902	3.75978	ns
T _{PERIODSS}	333 MHz CPUT and CPUC Period, SSC	Measured at 0V differential at 0.1s	3.00722	3.00782	ns
T _{PERIODSS}	400 MHz CPUT and CPUC Period, SSC	Measured at 0V differential at 0.1s	2.50601	2.50652	ns
T _{PERIODAbs}	100 MHz CPUT and CPUC Absolute period	Measured at 0V differential at 1 clock	9.91400	10.0860	ns
T _{PERIODAbs}	133 MHz CPUT and CPUC Absolute period	Measured at 0V differential at 1 clock	7.41425	7.58575	ns
T _{PERIODAbs}	166 MHz CPUT and CPUC Absolute period	Measured at 0V differential @ 1 clock	5.91440	6.08560	ns
T _{PERIODAbs}	200 MHz CPUT and CPUC Absolute period	Measured at 0V differential @ 1 clock	4.91450	5.08550	ns
T _{PERIODAbs}	266 MHz CPUT and CPUC Absolute period	Measured at 0V differential @ 1 clock	3.66463	3.83538	ns
T _{PERIODAbs}	333 MHz CPUT and CPUC Absolute period	Measured at 0V differential @ 1 clock	2.91470	3.08530	ns
T _{PERIODAbs}	400 MHz CPUT and CPUC Absolute period	Measured at 0V differential @ 1 clock	2.41475	2.58525	ns
T _{PERIODSSAbs}	100 MHz CPUT and CPUC Absolute period, SSC	Measured at 0V differential @ 1 clock	9.91406	10.1362	ns
T _{PERIODSSAbs}	133 MHz CPUT and CPUC Absolute period, SSC	Measured at 0V differential @ 1 clock	7.41430	7.62340	ns
T _{PERIODSSAbs}	166 MHz CPUT and CPUC Absolute period, SSC	Measured at 0V differential @ 1 clock	5.91444	6.11572	ns
T _{PERIODSSAbs}	200 MHz CPUT and CPUC Absolute period, SSC	Measured at 0V differential @ 1 clock	4.91453	5.11060	ns

AC Electrical Specifications (continued)

Parameter	Description	Condition	Min.	Max.	Unit
T _{PERIODSSAbs}	266 MHz CPUT and CPUC Absolute period, SSC	Measured at 0V differential @ 1 clock	3.66465	3.85420	ns
T _{PERIODSSAbs}	333 MHz CPUT and CPUC Absolute period, SSC	Measured at 0V differential @ 1 clock	2.91472	3.10036	ns
T _{PERIODSSAbs}	400 MHz CPUT and CPUC Absolute period, SSC	Measured at 0V differential @ 1 clock	2.41477	2.59780	ns
T _{CCJ}	CPU Cycle to Cycle Jitter	Measured at 0V differential	–	85	ps
T _{CCJ2}	CPU2_ITP Cycle to Cycle Jitter	Measured at 0V differential	–	125	ps
L _{ACC}	Long-term Accuracy	Measured at 0V differential	–	100	ppm
T _{SKEW}	CPU0 to CPU1 Clock Skew	Measured at 0V differential	–	100	ps
T _{SKEW2}	CPU2_ITP to CPU0 Clock Skew	Measured at 0V differential	–	150	ps
T _R / T _F	CPU Rising/Falling Slew rate	Measured differentially from ±150 mV	2.5	8	V/ns
T _{RFM}	Rise/Fall Matching	Measured single-endedly from ±75 mV	–	20	%
V _{HIGH}	Voltage High			1.15	V
V _{LOW}	Voltage Low		–0.3	–	V
V _{OX}	Crossing Point Voltage at 0.7V Swing		300	550	mV
SRC at 0.7V					
T _{DC}	SRC Duty Cycle	Measured at 0V differential	45	55	%
T _{PERIOD}	100 MHz SRC Period	Measured at 0V differential @ 0.1s	9.99900	10.0010	ns
T _{PERIODSS}	100 MHz SRC Period, SSC	Measured at 0V differential @ 0.1s	10.02406	10.02607	ns
T _{PERIODAbs}	100 MHz SRC Absolute Period	Measured at 0V differential @ 1 clock	9.87400	10.1260	ns
T _{PERIODSSAbs}	100 MHz SRC Absolute Period, SSC	Measured at 0V differential @ 1 clock	9.87406	10.1762	ns
T _{SKEW(window)}	Any SRC Clock Skew from the earliest bank to the latest bank	Measured at 0V differential	–	3.0	ns
T _{CCJ}	SRC Cycle to Cycle Jitter	Measured at 0V differential	–	125	ps
L _{ACC}	SRC Long Term Accuracy	Measured at 0V differential	–	100	ppm
T _R / T _F	SRC Rising/Falling Slew Rate	Measured differentially from ±150 mV	2.5	8	V/ns
T _{RFM}	Rise/Fall Matching	Measured single-endedly from ±75 mV	–	20	%
V _{HIGH}	Voltage High			1.15	V
V _{LOW}	Voltage Low		–0.3	–	V
V _{OX}	Crossing Point Voltage at 0.7V Swing		300	550	mV
DOT96 at 0.7V					
T _{DC}	DOT96 Duty Cycle	Measured at 0V differential	45	55	%
T _{PERIOD}	DOT96 Period	Measured at 0V differential at 0.1s	10.4156	10.4177	ns
T _{PERIODAbs}	DOT96 Absolute Period	Measured at 0V differential at 0.1s	10.1656	10.6677	ns
T _{CCJ}	DOT96 Cycle to Cycle Jitter	Measured at 0V differential at 1 clock	–	250	ps
L _{ACC}	DOT96 Long Term Accuracy	Measured at 0V differential at 1 clock	–	100	ppm
T _R / T _F	DOT96 Rising/Falling Slew Rate	Measured differentially from ±150 mV	2.5	8	V/ns
T _{RFM}	Rise/Fall Matching	Measured single-endedly from ±75 mV	–	20	%
V _{HIGH}	Voltage High			1.15	V
V _{LOW}	Voltage Low		–0.3	–	V
V _{OX}	Crossing Point Voltage at 0.7V Swing		300	550	mV
LCD_100_SSC at 0.7V					
T _{DC}	LCD_100 Duty Cycle	Measured at 0V differential	45	55	%
T _{PERIOD}	100 MHz LCD_100 Period	Measured at 0V differential at 0.1s	9.99900	10.0010	ns

AC Electrical Specifications (continued)

Parameter	Description	Condition	Min.	Max.	Unit
T _{PERIODSS}	100 MHz LCD_100 Period, SSC -0.5%	Measured at 0V differential at 0.1s	10.02406	10.02607	ns
T _{PERIODAbs}	100 MHz LCD_100 Absolute Period	Measured at 0V differential at 1 clock	9.74900	10.25100	ns
T _{PERIODSSAbs}	100 MHz LCD_100 Absolute Period, SSC	Measured at 0V differential @ 1 clock	9.74906	10.3012	ns
T _{CCJ}	LCD_100 Cycle to Cycle Jitter	Measured at 0V differential	–	250	ps
L _{ACC}	LCD_100 Long Term Accuracy	Measured at 0V differential	–	100	ppm
T _R / T _F	LCD_100 Rising/Falling Slew Rate	Measured differentially from ±150 mV	2.5	8	V/ns
T _{RFM}	Rise/Fall Matching	Measured single-endedly from ±75 mV	–	20	%
V _{HIGH}	Voltage High			1.15	V
V _{LOW}	Voltage Low		–0.3	–	V
V _{OX}	Crossing Point Voltage at 0.7V Swing		300	550	mV
PCI/PCIF at 3.3V					
T _{DC}	PCI Duty Cycle	Measurement at 1.5V	45	55	%
T _{PERIOD}	Spread Disabled PCIF/PCI Period	Measurement at 1.5V	29.99700	30.00300	ns
T _{PERIODSS}	Spread Enabled PCIF/PCI Period	Measurement at 1.5V	30.08421	30.23459	ns
T _{PERIODAbs}	Spread Disabled PCIF/PCI Period	Measurement at 1.5V	29.49700	30.50300	ns
T _{PERIODSSAbs}	Spread Enabled PCIF/PCI Period	Measurement at 1.5V	29.56617	30.58421	ns
T _{HIGH}	Spread Enabled PCIF and PCI high time	Measurement at 2V	12.27095	16.27995	ns
T _{LOW}	Spread Enabled PCIF and PCI low time	Measurement at 0.8V	11.87095	16.07995	ns
T _{HIGH}	Spread Disabled PCIF and PCI high time	Measurement at 2.0V	12.27365	16.27665	ns
T _{LOW}	Spread Disabled PCIF and PCI low time	Measurement at 0.8V	11.87365	16.07665	ns
T _R / T _F	PCIF/PCI Rising/Falling Slew Rate	Measured between 0.8V and 2.0V	1.0	4.0	V/ns
T _{SKEW}	Any PCI clock to Any PCI clock Skew	Measurement at 1.5V	–	1000	ps
T _{CCJ}	PCIF and PCI Cycle to Cycle Jitter	Measurement at 1.5V	–	500	ps
L _{ACC}	PCIF/PCI Long Term Accuracy	Measurement at 1.5V	–	100	ppm
48_M at 3.3V					
T _{DC}	Duty Cycle	Measurement at 1.5V	45	55	%
T _{PERIOD}	Period	Measurement at 1.5V	20.83125	20.83542	ns
T _{PERIODAbs}	Absolute Period	Measurement at 1.5V	20.48125	21.18542	ns
T _{HIGH}	48_M High time	Measurement at 2V	8.216563	11.15198	ns
T _{LOW}	48_M Low time	Measurement at 0.8V	7.816563	10.95198	ns
T _R / T _F	Rising and Falling Edge Rate	Measured between 0.8V and 2.0V	1.0	2.0	V/ns
T _{CCJ}	Cycle to Cycle Jitter	Measurement at 1.5V	–	350	ps
L _{ACC}	48M Long Term Accuracy	Measurement at 1.5V	–	100	ppm
27M_NSS/27M_SS at 3.3V					
T _{DC}	Duty Cycle	Measurement at 1.5V	45	55	%
T _{PERIOD}	Spread Disabled 27M Period	Measurement at 1.5V	37.03594	37.03813	ns
	Spread Enabled 27M Period	Measurement at 1.5V	37.03594	37.03813	ns
T _R / T _F	Rising and Falling Edge Rate	Measured between 0.4V and 2.0V	1.0	4.0	V/ns
T _{CCJ}	Cycle to Cycle Jitter	Measurement at 1.5V	–	200	ps
L _{ACC}	27_M Long Term Accuracy	Measured at crossing point V _{OX}	–	50	ppm
REF					
T _{DC}	REF Duty Cycle	Measurement at 1.5V	45	55	%

AC Electrical Specifications (continued)

Parameter	Description	Condition	Min.	Max.	Unit
T _{PERIOD}	REF Period	Measurement at 1.5V	69.82033	69.86224	ns
T _{PERIODAbs}	REF Absolute Period	Measurement at 1.5V	68.83429	70.84826	ns
T _{HIGH}	REF High time	Measurement at 2V	29.97543	38.46654	ns
T _{LOW}	REF Low time	Measurement at 0.8V	29.57543	38.26654	ns
T _R / T _F	REF Rising and Falling Edge Rate	Measured between 0.8V and 2.0V	1.0	4.0	V/ns
T _{SKEW}	REF Clock to REF Clock	Measurement at 1.5V	–	500	ps
T _{CCJ}	REF Cycle to Cycle Jitter	Measurement at 1.5V	–	1000	ps
L _{ACC}	Long Term Accuracy	Measurement at 1.5V	–	100	ppm
ENABLE/DISABLE and SET-UP					
T _{STABLE}	Clock Stabilization from Power-up		–	1.8	ms
T _{SS}	Stopclock Set-up Time		10.0	–	ns

Test and Measurement Set-up

For PCI Single-ended Signals and Reference

The following diagram shows the test load configurations for the single-ended PCI, USB, and REF output signals.

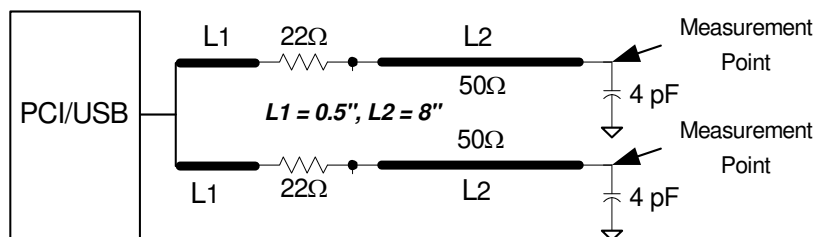

Figure 14. Single-ended PCI and USB Double Load Configuration

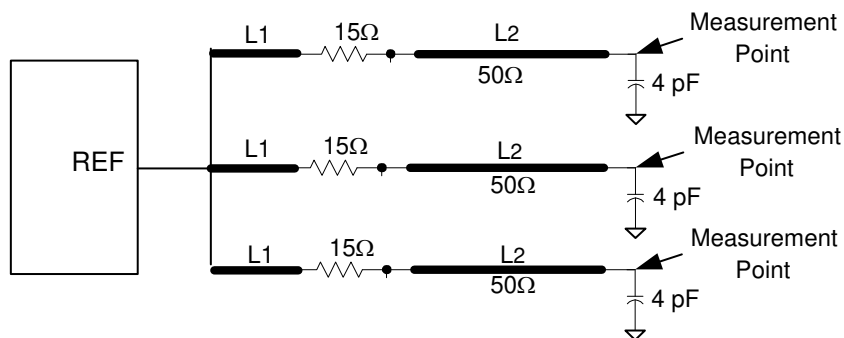

Figure 15. Single-ended REF Triple Load Configuration

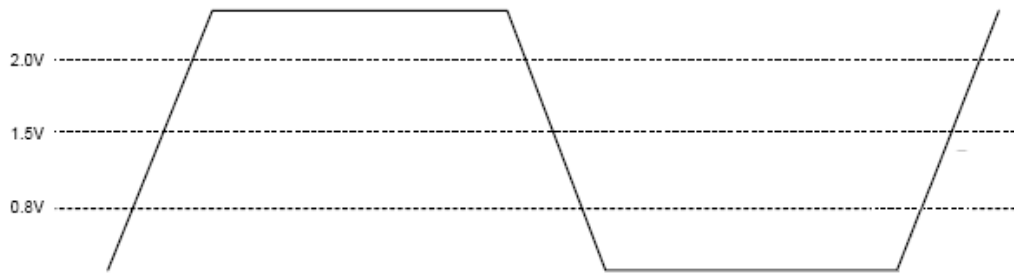

Figure 16. Single-ended Output Signals (for AC Parameters Measurement)

For CPU, SRC, and DOT96 Signals and Reference

This diagram shows the test load configuration for the differential CPU and SRC outputs

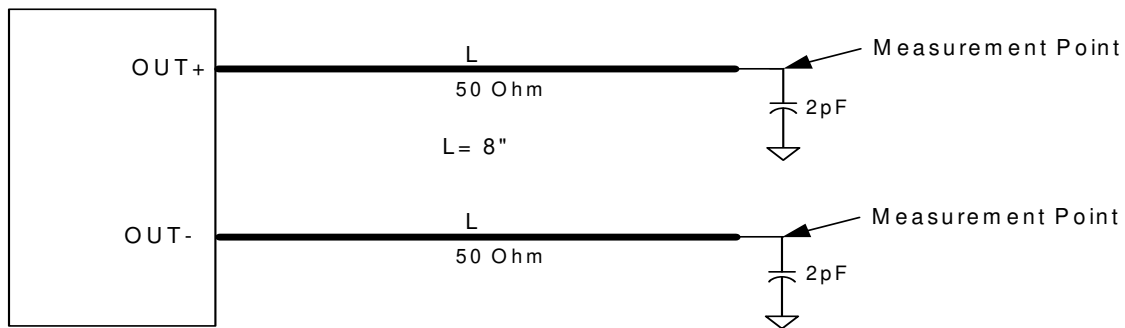

Figure 17. 0.7V Differential Load Configuration

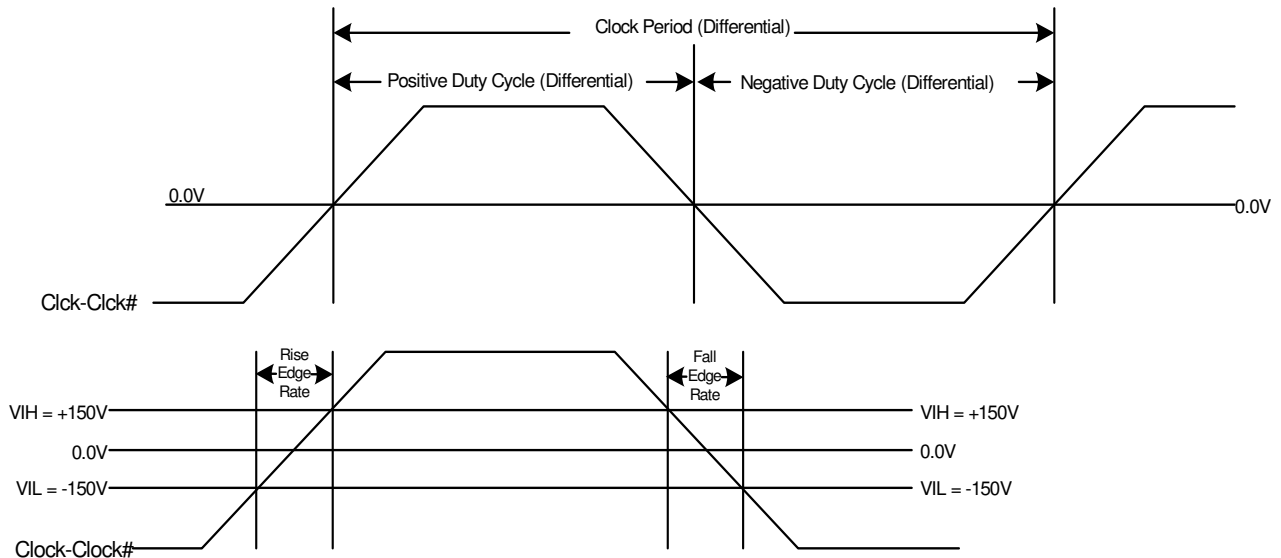

Figure 18. Differential Measurement for Differential Output Signals (for AC Parameters Measurement)

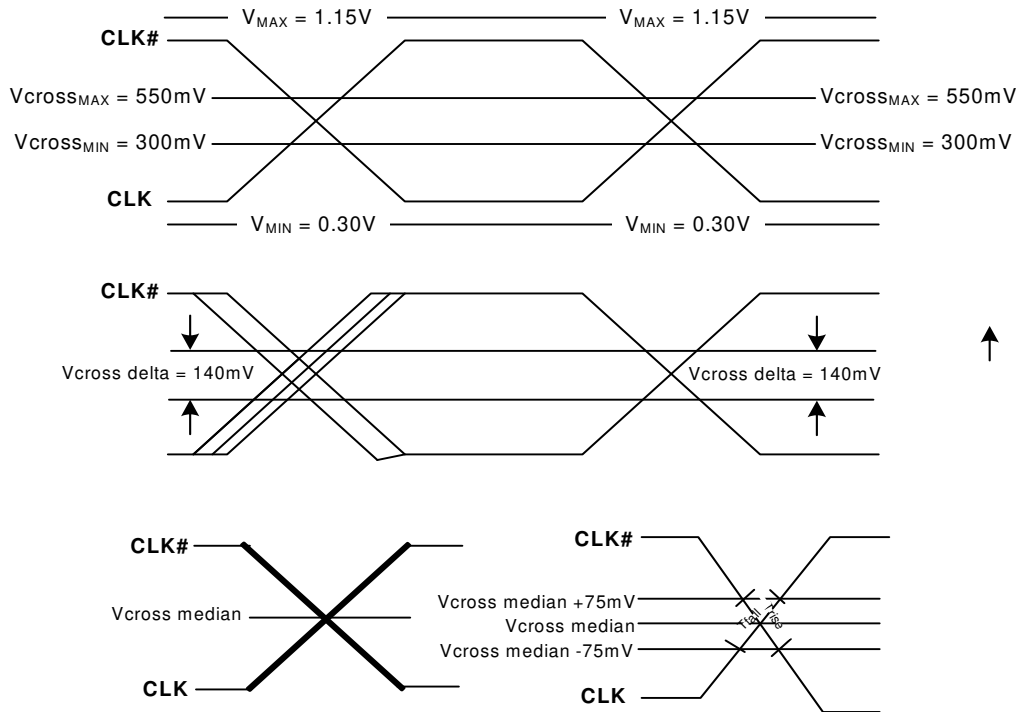

Figure 19. Single-ended Measurement for Differential Output Signals (for AC Parameters Measurement)

Ordering Information

Part Number	Package Type	Product Flow
Lead-free		
CY28548ZXC	64-pin TSSOP	Commercial, 0° to 85°C
CY28548ZXCT	64-pin TSSOP–Tape and Reel	Commercial, 0° to 85°C
CY28548LFXC	64-pin QFN	Commercial, 0° to 85°C
CY28548LFXCT	64-pin QFN–Tape and Reel	Commercial, 0° to 85°C

Package Diagrams

64-Lead Thin Shrunken Small Outline Package (6 mm x 17 mm) Z64

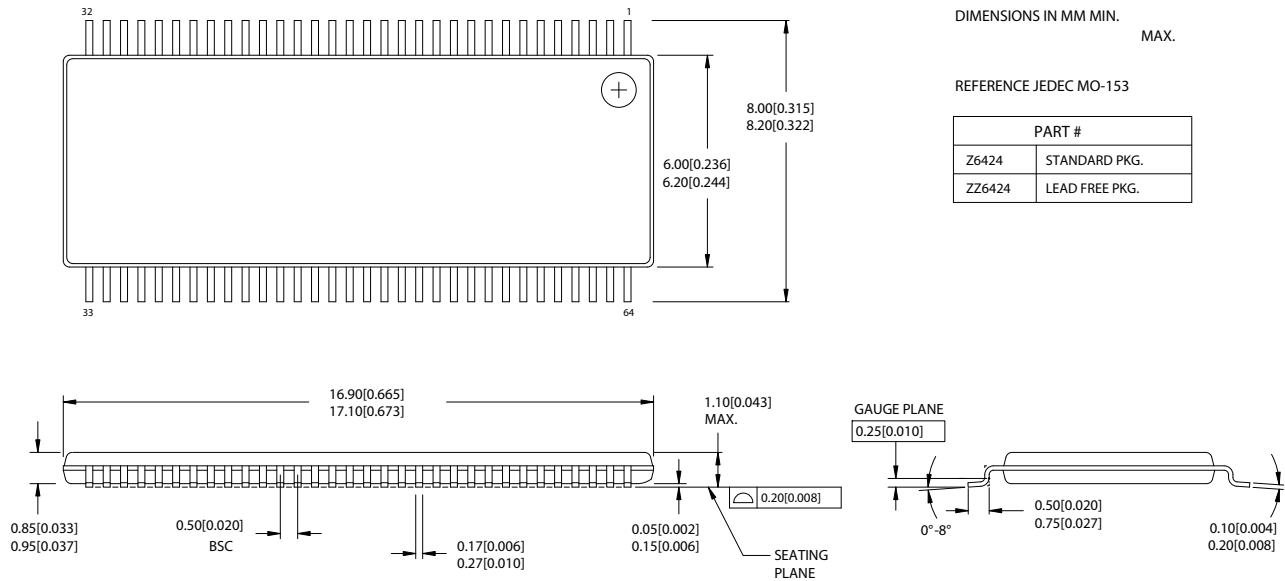

64-Lead QFN 9 x 9 mm (Punch Version) LF64A

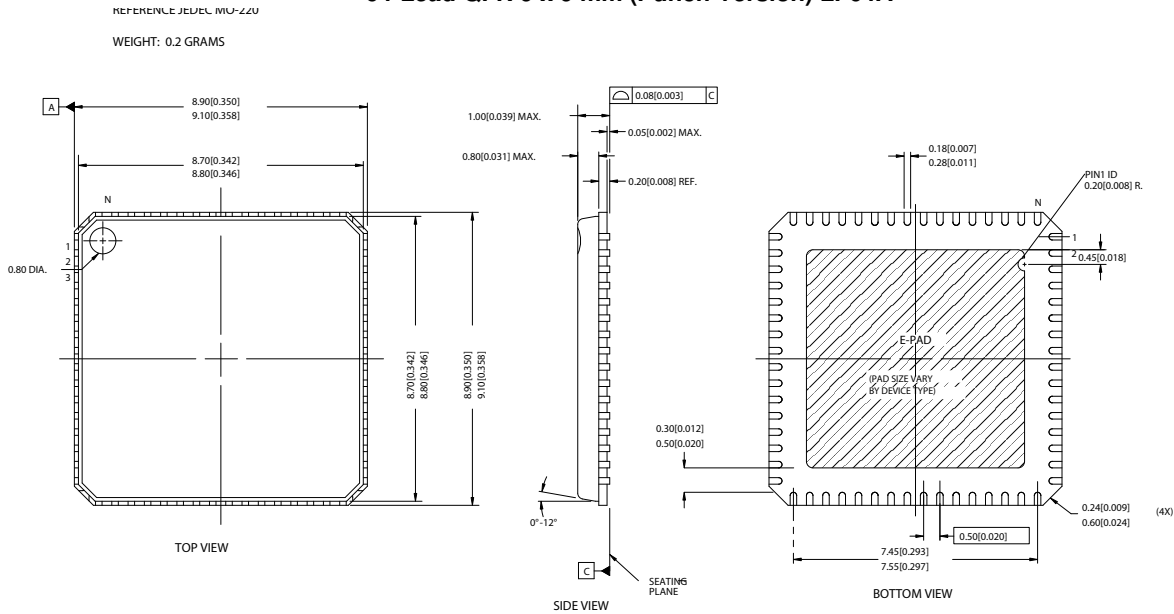



ClockBuilder Pro

One-click access to Timing tools, documentation, software, source code libraries & more. Available for Windows and iOS (CBGo only).

www.silabs.com/CBPro



Timing Portfolio
www.silabs.com/timing



SW/HW
www.silabs.com/CBPro



Quality
www.silabs.com/quality



Support and Community
community.silabs.com

Disclaimer

Silicon Laboratories intends to provide customers with the latest, accurate, and in-depth documentation of all peripherals and modules available for system and software implementers using or intending to use the Silicon Laboratories products. Characterization data, available modules and peripherals, memory sizes and memory addresses refer to each specific device, and "Typical" parameters provided can and do vary in different applications. Application examples described herein are for illustrative purposes only. Silicon Laboratories reserves the right to make changes without further notice and limitation to product information, specifications, and descriptions herein, and does not give warranties as to the accuracy or completeness of the included information. Silicon Laboratories shall have no liability for the consequences of use of the information supplied herein. This document does not imply or express copyright licenses granted hereunder to design or fabricate any integrated circuits. The products must not be used within any Life Support System without the specific written consent of Silicon Laboratories. A "Life Support System" is any product or system intended to support or sustain life and/or health, which, if it fails, can be reasonably expected to result in significant personal injury or death. Silicon Laboratories products are generally not intended for military applications. Silicon Laboratories products shall under no circumstances be used in weapons of mass destruction including (but not limited to) nuclear, biological or chemical weapons, or missiles capable of delivering such weapons.

Trademark Information

Silicon Laboratories Inc., Silicon Laboratories, Silicon Labs, SiLabs and the Silicon Labs logo, CMEMS®, EFM, EFM32, EFR, Energy Micro, Energy Micro logo and combinations thereof, "the world's most energy friendly microcontrollers", Ember®, EZLink®, EZMac®, EZRadio®, EZRadioPRO®, DSPLL®, ISOModem®, Precision32®, ProSLIC®, SiPHY®, USBXpress® and others are trademarks or registered trademarks of Silicon Laboratories Inc. ARM, CORTEX, Cortex-M3 and THUMB are trademarks or registered trademarks of ARM Holdings. Keil is a registered trademark of ARM Limited. All other products or brand names mentioned herein are trademarks of their respective holders.



Silicon Laboratories Inc.
400 West Cesar Chavez
Austin, TX 78701
USA

<http://www.silabs.com>