

AUX. VIEW  
SCALE 1:1  
4 CIRCUIT SHOWN

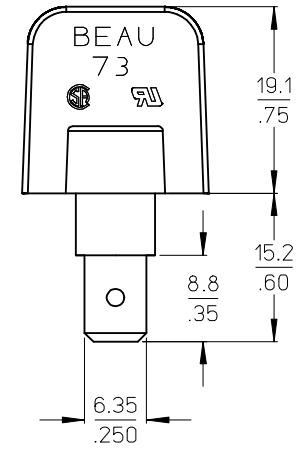
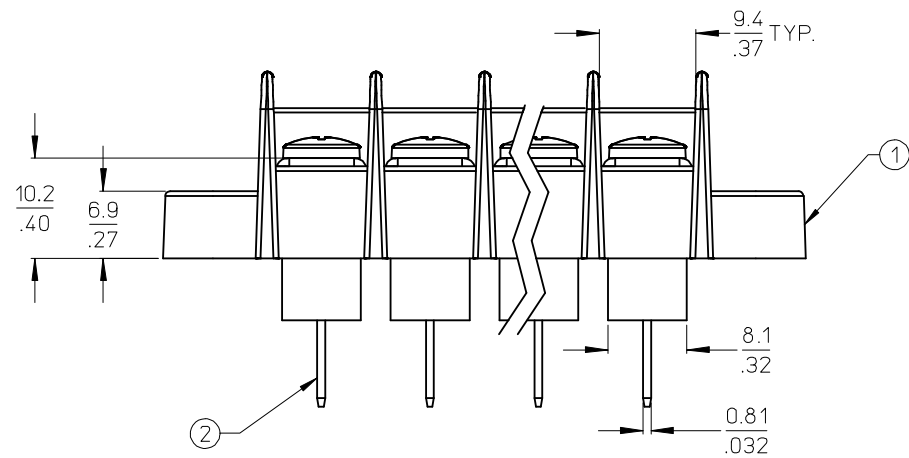

NOTES:

1. MATERIAL: SEE TABLE.
2. FINISHES: SEE TABLE.
3. PRODUCT SPECIFICATION: NOT REQUIRED.
4. "XX" REFERS TO THE QUANTITY OF CIRCUITS.
5. ROHS COMPLIANT.

4	XX	SCREW AND WASHER, #8-32, PAN HEAD (-50 OPT)	STEEL	ZN, CLEAR CHROMATE
3	XX	SCREW, #8-32, BIND. HEAD (-A OPT)	BRASS	NICKEL PLATE
2	XX	TERMINAL, QUICK CONNECT	BRASS	TIN PLATE
1	1	CS INSULATOR, SINGLE ROW	POLYESTER (PBT)	BLACK
ITEM	QTY.	DESCRIPTION	MATERIAL	FINISH

INITIAL RELEASE  
EC NO: WNA2009-0148  
DRAWN: JENC INAS 2008/09/01  
CHKD: CYORK 2008/09/09  
APPR: JMACNEIL 2008/09/10

QUALITY SYMBOLS  
▽=0  
▽/0

GENERAL TOLERANCES (UNLESS SPECIFIED)	
4 PLACES	± --- ± ---
3 PLACES	± --- ± .005
2 PLACES	± 0.13 ± .01
1 PLACE	± 0.3 ± ---
ANGULAR ± 2 °	
DRAFT WHERE APPLICABLE MUST REMAIN WITHIN DIMENSIONS	

DIMENSION STYLE  
MM/IN

DRAWN BY DATE  
JENC INAS 2008/08/22

CHECKED BY DATE  
CYORK 2008/08/25

APPROVED BY DATE  
JMACNEIL 2008/08/29

MATERIAL NO.  
SEE SHEET 2

SIZE  
B

SCALE  
2:1

DESIGN UNITS  
INCH

THIRD ANGLE PROJECTION

TITLE  
11.11MM [.438] SR BTS,  
CS FAST TAB ASY  
#8-32 SCREWS

MOLEX INCORPORATED

DOCUMENT NO.  
SD-38735-004

SHEET NO.  
1 OF 2

THIS DRAWING CONTAINS INFORMATION THAT IS PROPRIETARY TO MOLEX INCORPORATED AND SHOULD NOT BE USED WITHOUT WRITTEN PERMISSION

NO. OF CIRCUITS "XX"	DIM. "A"		DIM. "B"		DIM. "C"		DIM. "D"		ASSEMBLY MATERIAL NO. (-A OPTION)	ASSEMBLY MATERIAL NO. (-A-50 OPTION)
	mm	INCH	mm	INCH	mm	INCH	mm	INCH		
2	43.5	1.71	11.11	0.438	33.34	1.313	24.5	0.97	387356402	387356602
3	54.6	2.15	22.23	0.875	44.45	1.750	35.7	1.40	387356403	387356603
4	65.7	2.59	33.34	1.313	55.56	2.188	46.8	1.84	387356404	387356604
5	76.8	3.03	44.45	1.750	66.68	2.625	57.9	2.28	387356405	387356605
6	87.9	3.46	55.56	2.188	77.79	3.063	69.0	2.72	387356406	387356606
7	99.1	3.90	66.68	2.625	88.90	3.500	80.1	3.15	387356407	387356607
8	110.2	4.34	77.79	3.063	100.01	3.938	91.2	3.59	387356408	387356608
9	121.3	4.78	88.90	3.500	111.13	4.375	102.3	4.03	387356409	387356609
10	132.4	5.21	100.01	3.938	122.24	4.813	113.4	4.47	387356410	387356610
11	143.5	5.65	111.13	4.375	133.35	5.250	124.6	4.90	387356411	387356611
12	154.6	6.09	122.24	4.813	144.46	5.688	135.7	5.34	387356412	387356612
13	165.7	6.53	133.35	5.250	155.58	6.125	146.8	5.78	387356413	387356613
14	176.8	6.96	144.46	5.688	166.69	6.563	157.9	6.22	387356414	387356614
15	188.0	7.40	155.58	6.125	177.80	7.000	169.0	6.65	387356415	387356615
16	199.1	7.84	166.69	6.563	188.91	7.438	180.1	7.09	387356416	387356616
17	210.2	8.28	177.80	7.000	200.03	7.875	191.2	7.53	387356417	387356617
18	221.3	8.71	188.91	7.438	211.14	8.313	202.3	7.97	387356418	387356618
19	232.4	9.15	200.03	7.875	222.25	8.750	213.5	8.40	387356419	387356619
20	243.5	9.59	211.14	8.313	233.36	9.188	224.6	8.84	387356420	387356620
21	254.6	10.03	222.25	8.750	244.48	9.625	235.7	9.28	387356421	387356621
22	265.7	10.46	233.36	9.188	255.59	10.063	246.8	9.72	387356422	387356622
23	276.9	10.90	244.48	9.625	266.70	10.500	257.9	10.15	387356423	387356623
24	288.0	11.34	255.59	10.063	277.81	10.938	269.0	10.59	387356424	387356624
25	299.1	11.78	266.70	10.500	288.93	11.375	280.1	11.03	387356425	387356625
26	310.2	12.21	277.81	10.938	300.04	11.813	291.2	11.47	387356426	387356626
27	321.3	12.65	288.93	11.375	311.15	12.250	302.4	11.90	387356427	387356627
28	332.4	13.09	300.04	11.813	322.26	12.688	313.5	12.34	387356428	387356628
29	343.5	13.53	311.15	12.250	333.38	13.125	324.6	12.78	387356429	387356629
30	354.6	13.96	322.26	12.688	344.49	13.563	335.7	13.22	387356430	387356630

SEE SHEET ONE EC NO: WNA2009-0148 DRAWN: JENC INAS 2008/09/01 CHKD: CYORK 2008/09/09 APPR: JMACNEIL 2008/09/10	QUALITY SYMBOLS ▽=0 ▽=0	GENERAL TOLERANCES (UNLESS SPECIFIED)		DIMENSION STYLE MM/IN		SCALE 2:1	DESIGN UNITS INCH	THIRD ANGLE PROJECTION
		4 PLACES ± --- ± ---	DRAWN BY JENC INAS	DATE 2008/08/22	TITLE 11.11MM [.438] SR BTS, CS FAST TAB ASY #8-32 SCREWS			
		3 PLACES ± --- ± .005	CHECKED BY CYORK	DATE 2008/08/25				
		2 PLACES ± 0.13 ± .01	APPROVED BY JMACNEIL	DATE 2008/08/29	MOLEX INCORPORATED			
1 PLACE ± 0.3 ± ---	MATERIAL NO.		DOCUMENT NO.	SHEET NO.				
DRAFT WHERE APPLICABLE MUST REMAIN WITHIN DIMENSIONS		SEE CHART		SD-38735-004		2 OF 2		
THIS DRAWING CONTAINS INFORMATION THAT IS PROPRIETARY TO MOLEX INCORPORATED AND SHOULD NOT BE USED WITHOUT WRITTEN PERMISSION								