

SN54LS671, SN54LS672, SN74LS671, SN74LS672 4-BIT UNIVERSAL SHIFT REGISTERS/LATCHES WITH 3-STATE OUTPUTS

D2638, JANUARY 1981 — REVISED MARCH 1988

- 4-Bit Universal Shift Registers/Latches
- Multiplexed Outputs for Shift Register or Latched Data
- Choice of Direct SR Clear ('LS671) or Synchronous SR Clear ('LS672)
- 3-State Outputs Drive Bus Lines Directly
- Expandable to Any Word Length

description

The 'LS671 and 'LS672 each contain a 4-bit universal shift register (similar to the 'LS194A) and a 4-bit storage register (similar to the 'LS175) multiplexed to a 3-state output stage (similar to the 'LS258). The user has the option of selecting the shift or storage register via the register/shift select input R/\bar{S} . The 'LS671 has a direct-overriding shift register clear while the 'LS672 features a synchronous shift register clear. The shift register has four distinct modes of operation, namely:

- Inhibit clock (do nothing)
- Shift right (in the direction Q_A toward Q_D)
- Shift left (in the direction Q_D toward Q_A)
- Parallel (broadside) load

A cascade output for the shift register is provided so that full shift register functionality is provided even while the outputs are in the high-impedance mode. The cascade output presents Q_A data in the shift-left mode, Q_D data in the shift-right mode.

Both the shift register clock and the latch clock are triggered on the positive transition. The output control (\bar{G}) activates Q_A thru Q_D when low, it places Q_A thru Q_D into the high-impedance state when high.

SN54LS671, SN54LS672 . . . J PACKAGE
SN74LS671, SN74LS672 . . . DW OR N PACKAGE
(TOP VIEW)

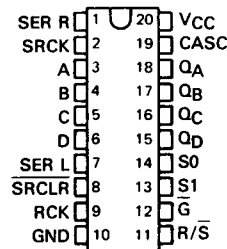

SN54LS671, SN54LS672 . . . FK PACKAGE
(TOP VIEW)

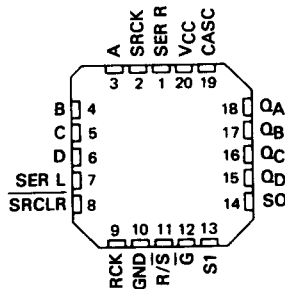

2

TTL Devices

PRODUCTION DATA documents contain information current as of publication date. Products conform to specifications per the terms of Texas Instruments standard warranty. Production processing does not necessarily include testing of all parameters.

TEXAS
INSTRUMENTS

POST OFFICE BOX 655012 • DALLAS, TEXAS 75265

2-1111

SN54LS671, SN54LS672, SN74LS671, SN74LS672
4-BIT UNIVERSAL SHIFT REGISTERS/LATCHES WITH 3-STATE OUTPUTS

logic diagram (positive logic)

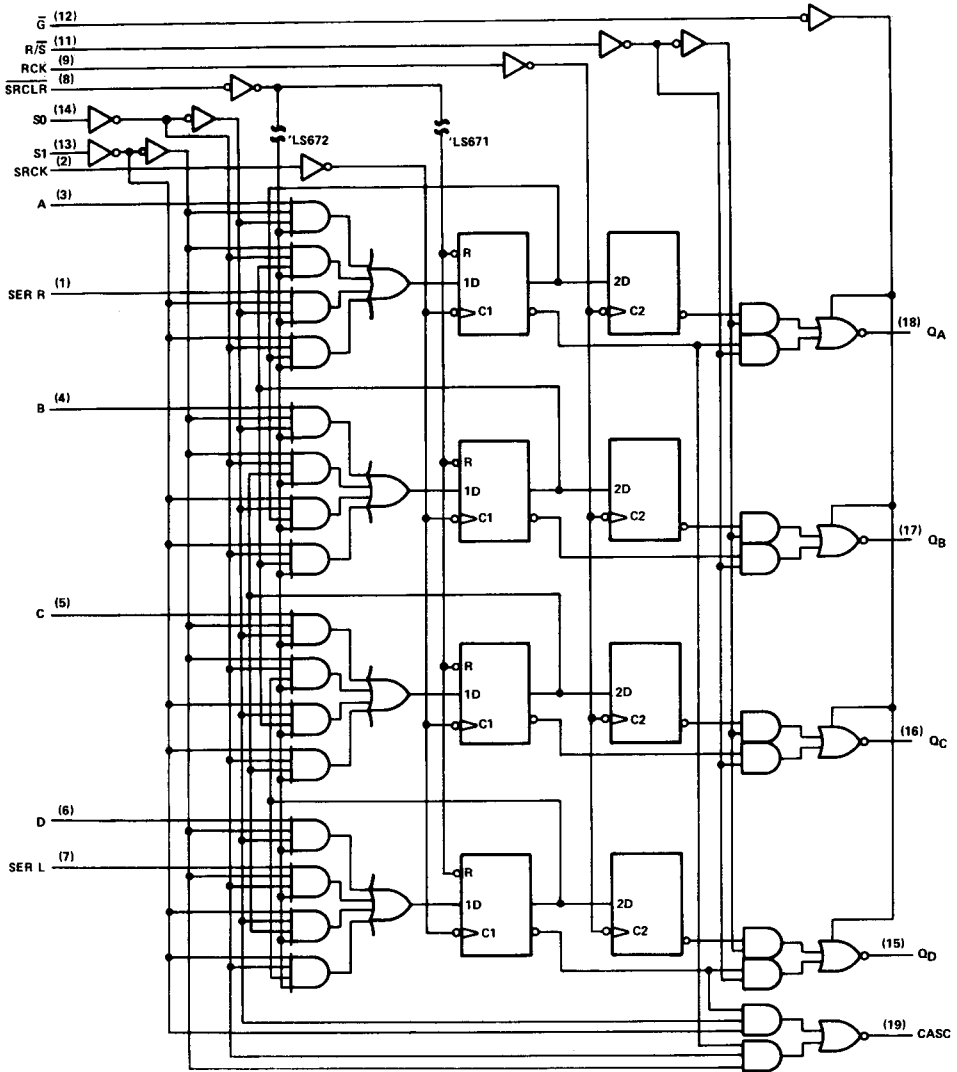

Pin numbers shown are for DW, J and N packages.

2

TTL Devices

SN54LS671, SN54LS672, SN74LS671, SN74LS672 4-BIT UNIVERSAL SHIFT REGISTERS/LATCHES WITH 3-STATE OUTPUTS

logic symbols †

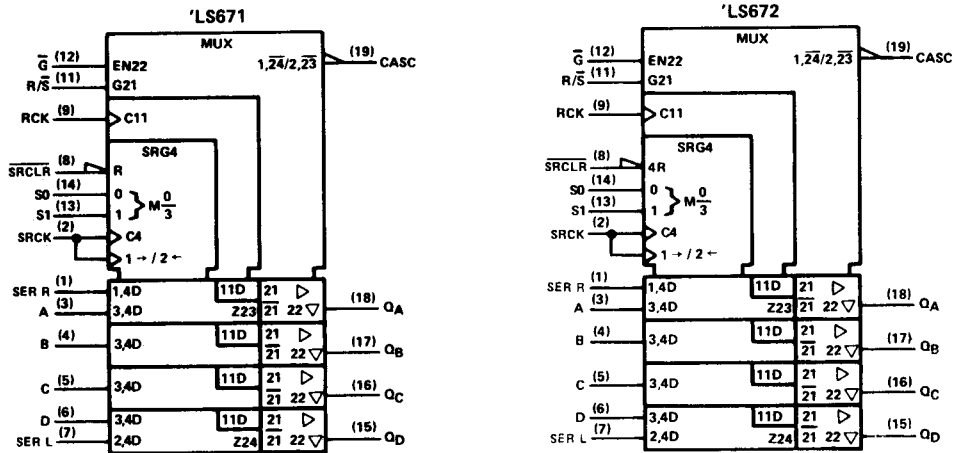

† These symbols are in accordance with ANSI/IEEE Std. 91-1984 and IEC Publication 617-12. Pin numbers shown are for DW, J, and N packages.

FUNCTION TABLE

\bar{G}	R/S	SRCLR	SR MODE		SRCK		SERIAL INPUTS		PARALLEL INPUTS				PARALLEL OUTPUTS				CASC ‡
			S1	S0	'LS671	'LS672	SL	SR	A	B	C	D	QA	QB	QC	QD	
L	L	L	X	X	X	†	X	X	X	X	X	X	L	L	L	L	(‡)
L	L	H	X	X	L	L	X	X	X	X	X	X	QA0	QB0	QC0	QD0	(‡)
L	L	H	L	L	X	X	X	X	X	X	X	X	QA0	QB0	QC0	QD0	H
L	L	H	L	H	†	†	X	H	X	X	X	X	H	QA _n	QB _n	QC _n	QC _n
L	L	H	L	H	†	†	X	L	X	X	X	X	L	QA _n	QB _n	QC _n	QC _n
L	L	H	H	L	†	†	H	X	X	X	X	X	QB _n	QC _n	QD _n	H	QB _n
L	L	H	H	L	†	†	L	X	X	X	X	X	QB _n	QC _n	QD _n	L	QB _n
L	L	H	H	H	†	†	X	X	a	b	c	d	a	b	c	d	H
H	X	X	L	H	†	†	X	X	X	X	X	X	Z	Z	Z	Z	QC _n
H	X	X	H	L	†	†	X	X	X	X	X	X	Z	Z	Z	Z	QB _n
L	H	X	X	X	X	X	X	X	X	X	X	X	Internal register contents				(‡)

When the output control \bar{G} is high, the 3-state outputs are disabled to the high-impedance state; however, sequential operation of the shift register and the output at CASC are not affected.

H = high level (steady state)

L = low level (steady state)

X = irrelevant (any input, including transitions)

† = transition from low to high level

a, b, c, d = the level of steady-state input at A, B, C, or D, respectively

QA0, QB0, QC0, QD0 = the level of QA, QB, QC, or QD, respectively, before the indicated steady-state input conditions were established

QA_n, QB_n, QC_n = the level of QA, QB, or QC, respectively, before the most-recent transition of the clock

Z = high-impedance state

‡ The cascade output displays the D bit of the shift register in mode 1 (S1, S0 = L, H), the A bit in mode 2 (S1, S0 = HL), and is inactive (H) in modes 0 and 3 (S1, S0 = LL and HH).

2
TTL Devices

SN54LS671, SN54LS672, SN74LS671, SN74LS672

4-BIT UNIVERSAL SHIFT REGISTERS/LATCHES WITH 3-STATE OUTPUTS

schematics of inputs and outputs

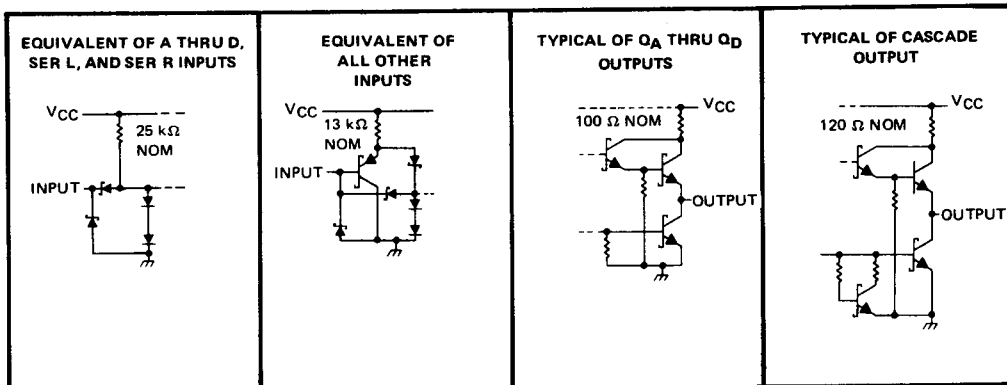

2

TTL Devices

absolute maximum ratings over operating free-air temperature range (unless otherwise noted)

Supply voltage V_{CC} (see Note 1)	7 V
Input voltage	7 V
Off-state output voltage	5.5 V
Operating free-air temperature range: SN54LS671, SN54LS672	-55°C to 125°C
SN74LS671, SN74LS672	0°C to 70°C
Storage temperature range	-65°C to 150°C

NOTE 1: Voltage values are with respect to the network ground terminal.

recommended operating conditions

		SN54LS'			SN74LS'			UNIT
		MIN	NOM	MAX	MIN	NOM	MAX	
V_{CC}	Supply voltage	4.5	5	5.5	4.75	5	5.25	V
I_{OH}	High-level output current	Cascade out		-0.4	-0.4		mA	
		Q _A , Q _B , Q _C , Q _D		-1	-2.6			
I_{OL}	Low-level output current	Cascade out		4	8		mA	
		Q _A , Q _B , Q _C , Q _D		12	24			
t_w	Width of SRCK, RCK, or SRCLR ('LS671 only) input pulse	30			30			ns
t_{su}	Inactive state setup time	SRCLR before SRCK ↑ ('LS671 only)			30			ns
t_{su}	Setup time	S0 or S1 to SRCK ↑		45	45		ns	
		SRCLR ↓ ('LS672 only) to SRCK ↑		25	25			
		A, B, C, D to SRCK ↑		30	30			
		SRCK ↑ to RCK ↑		30	30			
		SER to SRCK ↑		35	35			
t_h	Hold time	Any input from SRCK ↑			0			ns
T_A	Operating free-air temperature	-55		125	0		70	°C

SN54LS671, SN54LS672, SN74LS671, SN74LS672

4-BIT UNIVERSAL SHIFT REGISTERS/LATCHES WITH 3-STATE OUTPUTS

electrical characteristics over recommended operating free-air temperature range (unless otherwise noted)

PARAMETER		TEST CONDITIONS†		SN54LS*			SN74LS*			UNIT
				MIN	TYP‡	MAX	MIN	TYP‡	MAX	
V _{IH}	High-level input voltage				2					V
V _{IL}	Low-level input voltage					0.7			0.8	V
V _{IK}	Input clamp voltage		V _{CC} = MIN, I _I = -18 mA					-1.5		V
V _{OH}	High-level output voltage	Q _A - Q _D	V _{CC} = MIN, V _{IH} = 2 V, I _{OH} = -1 mA	2.4	3.1					V
		Q _A - Q _D	I _{OH} = -2.6 mA			2.4	3.1			
		CASC	V _{IL} = V _{IL max} , I _{OH} = -400 μA	2.5	3.2	2.7	3.2			
V _{OL}	Low-level output voltage	Q _A - Q _D	V _{CC} = MIN, V _{IH} = 2 V, I _{OL} = 12 mA		0.25	0.4	0.25	0.4		V
		Q _A - Q _D		I _{OL} = 24 mA				0.35	0.5	
		CASC	I _{OL} = 4 mA		0.25	0.4	0.25	0.4		
		CASC	I _{OL} = 8 mA				0.35	0.5		
I _{OZH}	Off-state output current, high-level voltage applied	Q _A - Q _D	V _{CC} = MAX, V _{IH} = 2 V, V _O = 2.7 V, V _{IL} = V _{IL max}			20			20	μA
I _{OZL}	Off-state output current, low-level voltage applied	Q _A - Q _D	V _{CC} = MAX, V _{IH} = 2 V, V _O = 0.4 V, V _{IL} = V _{IL max}			-20			-20	μA
I _I	Input current at maximum input voltage		V _{CC} = MAX, V _I = 7 V			0.1			0.1	mA
I _{IH}	High-level input current		V _{CC} = MAX, V _I = 2.7 V			20			20	μA
I _{IL}	Low-level input current	A, B, C, D	V _{CC} = MAX, V _I = 0.4 V			-0.4			-0.4	mA
		All others				-0.2			-0.2	
I _{OS}	Short-circuit output current§	Q _A - Q _D	V _{CC} = MAX, V _O = 0 V			-30	-130	-30	-130	mA
		CASC				-20	-100	-20	-100	
I _{CC}	Supply current	All outputs low	V _{CC} = MAX, All outputs open	See Note 2	35	70	35	70	mA	
		All outputs high		See Note 3	30	65	30	65		
		Q _A thru Q _D , at Hi-Z	See Note 4	37	70	37	70			

† For conditions shown as MIN or MAX, use the appropriate value specified under recommended operating conditions.

‡ All typical values are at V_{CC} = 5 V, T_A = 25°C.

§ Not more than one output should be shorted at a time and duration of the short-circuit should not exceed one second.

- NOTES: 2. I_{CC}L is tested after two 0-V to 4.5 V to 0-V pulses have been applied to SRCK and RCK while S0 is at 4.5 V and all other inputs are grounded.
3. I_{CC}H is tested after two 4.5-V to 0-V to 4.5-V pulses have been applied to SRCK and RCK while all other inputs are at 4.5 V.
4. I_{CC}Z is tested after two 0-V to 4.5-V to 0-V pulses have been applied to SRCK and RCK while S0 and \bar{G} are at 4.5 V and all other inputs are grounded.

2

TTL Devices

SN54LS671, SN54LS672, SN74LS671, SN74LS672 4-BIT UNIVERSAL SHIFT REGISTERS/LATCHES WITH 3-STATE OUTPUTS

switching characteristics, $V_{CC} = 5\text{ V}$, $T_A = 25^\circ\text{C}$, see note 5

PARAMETER	FROM (INPUT)	TO (OUTPUT)	TEST CONDITIONS		'LS671			'LS672			UNIT		
			MODE	LOAD	MIN	TYP	MAX	MIN	TYP	MAX			
t_{PLH}	SRCK \uparrow	CASCADE	SHIFT LEFT OR RIGHT	$R_L = 2\text{ k}\Omega$, $C_L = 15\text{ pF}$	31	45	31	45	ns				
t_{PHL}					14	25	14	25					
t_{PLH}	S0, S1				SR CLEAR	11	20	12	20	ns			
t_{PHL}						11	20	12	20				
t_{PHL}	SRCK \uparrow					19	30	19	30	ns			
t_{PHL}	SRCLR \downarrow					19	30	19	30	ns			
t_{PLH}	SRCK \uparrow	$Q_A - Q_D$	SHIFT LEFT OR RIGHT	$R_L = 667\ \Omega$, $C_L = 45\text{ pF}$		10	20	10	20	ns			
t_{PHL}						16	25	16	25				
t_{PLH}					SR LOAD	10	20	10	20	ns			
t_{PHL}						15	25	15	25				
t_{PHL}					SR CLEAR	17	30	17	30	ns			
t_{PHL}						21	30	21	30				
t_{PHL}	SRCLR \downarrow		10		20	10	20	ns					
t_{PHL}	RCK \uparrow		15		25	15	25						
t_{PLH}	R/\bar{S} \uparrow		MUX		3-STATE ENABLE	$R_L = 667\ \Omega$, $C_L = 5\text{ pF}$	12	25	13	25	ns		
t_{PHL}							15	25	15	25			
t_{PLH}	R/\bar{S} \downarrow						3-STATE DISABLE	$R_L = 667\ \Omega$, $C_L = 5\text{ pF}$	17	25	17	25	ns
t_{PHL}									16	25	16	25	
t_{PZH}	\bar{G} \downarrow	16		25					16	25	ns		
t_{PZL}	\bar{G} \uparrow	19		30					19	30			
t_{PHZ}		3-STATE DISABLE	16	25	16	25			ns				
t_{PLZ}	16		25	16	25								

NOTE 5: Load circuits and voltage waveforms are shown in Section 1.

2
TTL Devices

TYPICAL APPLICATION DATA

The 'LS671 or 'LS672 can easily be expanded utilizing the cascade output and the SER L and SER R inputs. A typical expansion is shown below.

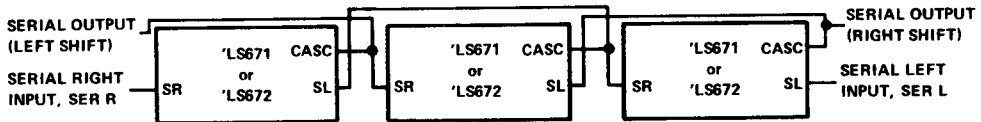

FIGURE 1 - 'LS671, 'LS672 EXPANDED TO 12 BITS, (3 PACKAGES)

Any desired word length may be obtained using the scheme shown. Corresponding control pins of all the packages are tied in common, i.e., all S0 pins are connected together, all S1 pins are connected together, etc.