

LEVER BODY

Glass-fibre reinforced polyamide based (PA) technopolymer, grey-black colour, matte finish.

PUSH BUTTON

Technopolymer, RAL 2004 orange colour, glossy finish. On request and for sufficient quantities it can be supplied in one of the other Ergostyle colours.

STANDARD EXECUTIONS

Glass-fibre reinforced technopolymer clamping element with retaining pin, black colour, with knurling on the protruding part to make initial tightening easier. AISI 302 stainless steel return spring. For quick assembly (ELESA patent) six-lobe socket ISO 10664 to fit TORX® T15 tool (registered trademark of TEXTRON INC.).

- **ERX-AV-B:** brass boss, threaded blind hole.
- **ERX-AV-p:** zinc-plated steel threaded stud, chamfered flat end UNI 947 : ISO 4753 (see Technical data on page A-10).

FEATURES AND APPLICATIONS

Even if it has a plastic push button, ERX-AV adjustable handle offers the possibility of a quick initial screwing during assembly by means of electric or pneumatic screwdrivers with controlled tightening torque system.

STRESS RESISTANCE

See ERX. page 324.

SPECIAL EXECUTIONS ON REQUEST

Lever body in orange colour.
Bosses and studs with different threadings.

INSTRUCTIONS OF USE

For clamping, lift the lever to disengage the clamping device teeth and bring it back to start position. By releasing the lever, the return spring automatically engages the teeth.



ERGOSTYLE® ELESA Original design

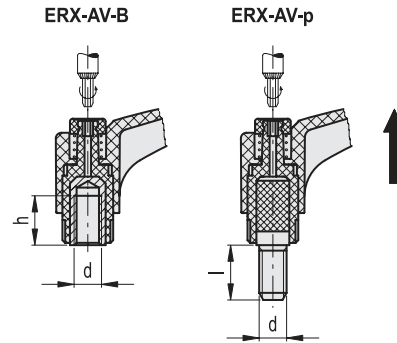
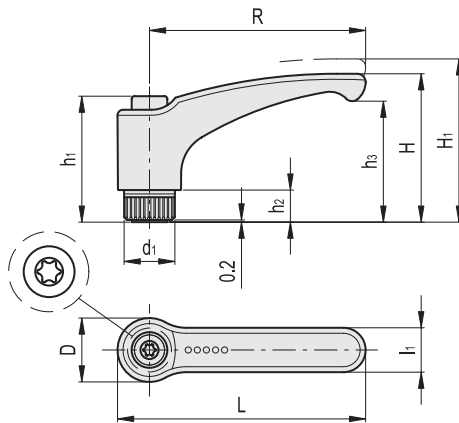
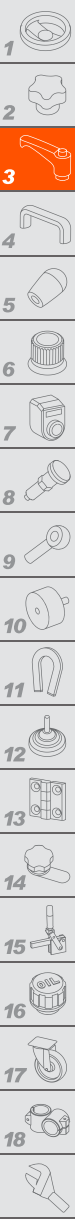

Conversion Table	
1 mm = 0.039 inch	
R	
mm	inch
78	3.07

ERX-AV-B

METRIC

Code	Description	R	d6H	L	D	H	H1	h	h1	h2	h3	d1	li	Teeth no.	⚖
233158-C2	ERX.78 AV B-M10-C2	78	M10	89.5	23	54	58	18	45	12	44	19	16	24	44
233163-C2	ERX.78 AV B-M12-C2	78	M12	89.5	23	54	58	17	45	12	44	19	16	24	43

ERX-AV-p

Code	Description	R	d6g	L	D	H	H1	h1	h2	h3	d1	li	Teeth no.	⚖	
234518-C2	ERX.78 AV p-M10x20-C2	78	M10	89.5	23	54	58	45	12	44	19	20	16	24	58
234528-C2	ERX.78 AV p-M10x30-C2	78	M10	89.5	23	54	58	45	12	44	19	30	16	24	64
234538-C2	ERX.78 AV p-M10x40-C2	78	M10	89.5	23	54	58	45	12	44	19	40	16	24	70
234543-C2	ERX.78 AV p-M10x50-C2	78	M10	89.5	23	54	58	45	12	44	19	50	16	24	76

Clamping levers