

SD-6482-1*

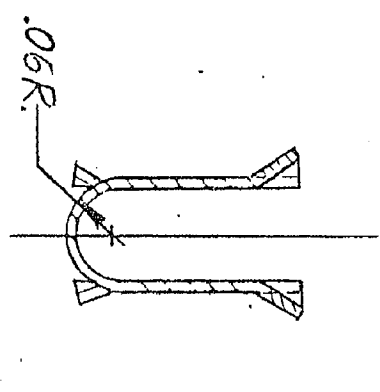
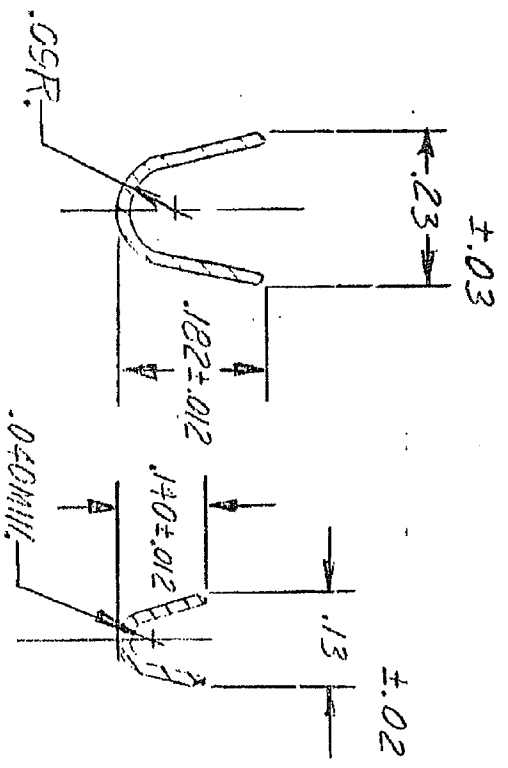
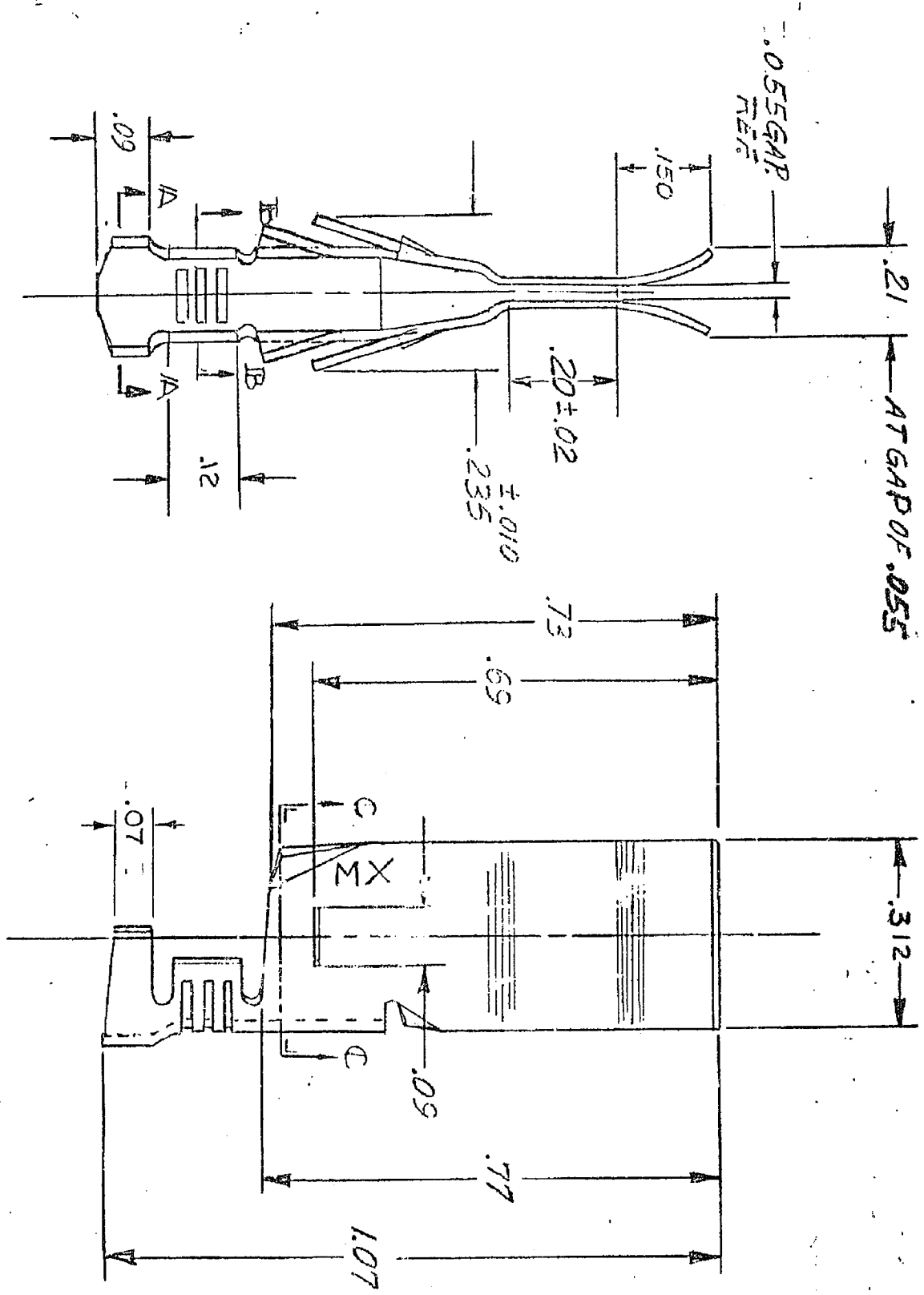

NOTES:
 ▲ FOR CRIMPING 14 TO 18 A.W.G. WIRE.

MATERIAL:
 BRONZE, HIGH TEMPERATURE, .016 THICK.

PART No	ENG No	DESCRIPTION
05-12-1102	6482-1	CHAIN

- D DELETE PART NO. ECR U2-1706 23-01-20 AG
- C .07 ADDED. ECR U8-2273 11-29-88 MB
- B REVISE MAT'L. CALLOUT BRONZE WAS BRASS & ADD EDP NO. TO 6482-1L PER ERO # 22731 6-12-86 JCS MB
- A ADD EDP # TO 6482-1 PER ERO # 19397 10-5-84 JCS
- 1 X-RELEASE PER ERO # 14276 10-12-81 JOK

REVISIONS

UNLESS OTHERWISE SPECIFIED
 TOLERANCES:
 3-PLACE DEC. DIMS ± .010
 2-PLACE DEC. DIMS ± .014
 ANGULAR ± 1/2°

DRAFT WHEN APPLICABLE MUST REMAIN WITHIN DIMENSIONS, UNLESS OTHERWISE SPECIFIED.
 DO NOT SCALE DRAWING

TERMINAL

MOLEX PRODUCTS CO.

DATE 10-12-81

SD-6482-1*

DOWNERS GROVE, ILL. 60515, U.S.A.

THIS DRAWING CONTAINS INFORMATION THAT IS PROPRIETARY TO THE MOLEX PRODUCTS COMPANY AND SHOULD NOT BE USED WITHOUT WRITTEN PERMISSION.

NO P.S.