

DATA SHEET

# SKY13449-001: 0.5 to 3.0 GHz SP3T High-Power Antenna Tuning Switch in a WLCSP Package

## Applications

- LTE TDD/FDD transmit/receive
- Antenna tuning
- GSM transmit
- Embedded modules

## Features

- Broadband frequency range: 0.5 to 3.0 GHz
- Low insertion loss: 0.7 dB @ 2.7 GHz
- SP3T for shunt antenna tuning applications
- No external DC blocking capacitors required
- Single GPIO control line with V<sub>DD</sub> voltage regulator:
  - V<sub>CTL</sub> = 1.35 to 2.7 V
  - V<sub>DD</sub> = 2.5 to 4.8 V
- Small, 9-bump WLCSP, 262 μm diameter, 400 μm pitch (1.272 x 1.272 x 0.504 mm) package (MSL1, 260 °C per JEDEC J-STD-020)



Skyworks Green™ products are compliant with all applicable legislation and are halogen-free. For additional information, refer to *Skyworks Definition of Green™*, document number SQ04-0074.

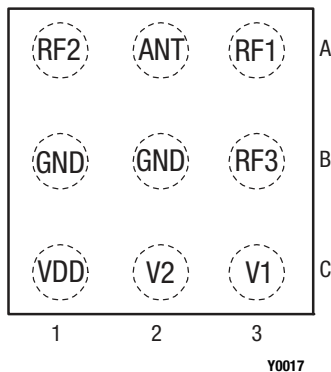

**Figure 2. SKY13449-001 Pinout (Top View, Bumps Facing Down)**

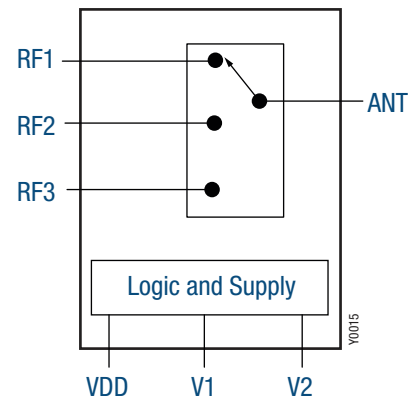

**Figure 1. SKY13449-001 Block Diagram**

## Description

The SKY13449-001 is a single-pole, triple-throw (SP3T) designed for antenna tuning applications that require very low R<sub>ON</sub> and CoFF. The SKY13449-001 can also be used for LTE/WCDMA/GSM transmit applications. Switching is controlled by an integrated GPIO interface with two control pins. Depending on the logic voltage level applied to the control pins, the antenna port is connected to one of the switched RF outputs (RF1, RF2, or RF3) through a low-insertion loss path, while the path between the antenna port and the other RF ports is in a high-isolation state.

No external DC blocking capacitors are required as long as no DC voltage is applied on any RF path.

The SKY13449-001 is provided in a compact 9-bump, 1.272 x 1.272 x 0.504 mm Wafer Level Chip Scale Package (WLCSP) that meets requirements for board-level assembly. Bump diameters are 262 microns with a minimum bump pitch of 400 microns.

A functional block diagram is shown in Figure 1. The pin configuration and package are shown in Figure 2. Signal pin assignments and functional pin descriptions are provided in Table 1.

**Table 1. SKY13449-001 Signal Descriptions**

| Pin | Name | Description                    | Pin | Name | Description                    |
|-----|------|--------------------------------|-----|------|--------------------------------|
| A1  | RF2  | RF I/O. Throw 2 of the switch. | B3  | RF3  | RF I/O. Throw 3 of the switch. |
| B1  | GND  | Ground                         | A3  | RF1  | RF I/O. Throw 1 of the switch  |
| C1  | VDD  | Supply voltage                 | A2  | ANT  | Antenna                        |
| C2  | V2   | Digital control input #2       | B2  | GND  | Ground                         |
| C3  | V1   | Digital control input #1       |     |      |                                |

**Electrical and Mechanical Specifications**

The absolute maximum ratings of the SKY13449-001 are provided in Table 2. Electrical specifications are provided in Table 3.

The state of the SKY13449-001 is determined by the logic provided in Table 4.

**Table 2. SKY13449-001 Absolute Maximum Ratings (Note 1)**

| Parameter  | Symbol | Minimum | Maximum             | Units       |
|--|--------|---------|---------------------|-------------|
| Supply voltage   | VDD    | 2.5     | 5.0                 | V           |
| Digital control voltage  | VCTL   | -0.5    | +3.0                | V           |
| GSM RF input power:<br>Low band<br>High band   | PIN    |         | +36<br>+34          | dBm<br>dBm  |
| Operating temperature  | TOP    | -30     | +90                 | °C          |
| Storage temperature  | TSTG   | -55     | +150                | °C          |
| Electrostatic discharge:<br>Charged Device Model (CDM)<br>Human Body Model (HBM)<br>Machine Model (MM) | ESD    |         | 1000<br>1000<br>100 | V<br>V<br>V |

**Note 1:** Exposure to maximum rating conditions for extended periods may reduce device reliability. There is no damage to device with only one parameter set at the limit and all other parameters set at or below their nominal value. Exceeding any of the limits listed here may result in permanent damage to the device.

**CAUTION:** Although this device is designed to be as robust as possible, electrostatic discharge (ESD) can damage this device. This device must be protected at all times from ESD. Static charges may easily produce potentials of several kilovolts on the human body or equipment, which can discharge without detection. Industry-standard ESD precautions should be used at all times.

**Table 3. SKY13449-001 Electrical Specifications (1 of 2) (Note 1)**  
**(V<sub>DD</sub> = 2.65 V, T<sub>OP</sub> = +25 °C, Characteristic Impedance [Z<sub>0</sub>] = 50 Ω, Unless Otherwise Noted)**

| Parameter                               | Symbol             | Test Condition  | Min            | Typical             | Max                  | Units          |
|---|--------------------|---|----------------|---------------------|----------------------|----------------|
| <b>DC Specifications</b>                |                    |   |                |                     |                      |                |
| Supply voltage                          | V <sub>DD</sub>    |   | 2.50           | 2.65                | 4.80                 | V              |
| Control voltage:<br>Low                 | V <sub>CTL_L</sub> |   | 0              | 0                   | +0.45                | V              |
| High                                    | V <sub>CTL_H</sub> |   | +1.35          | +1.80               | +2.70                | V              |
| Current on V1, V2                       | I <sub>CTL</sub>   |   |                |                     | 5                    | μA             |
| Supply current                          | I <sub>DD</sub>    | V <sub>DD</sub> = 2.65 V, V1 or V2 = V <sub>CTL_H</sub>   |                | 30                  | 65                   | μA             |
| DC supply turn-on/turn-off time         | t <sub>ON</sub>    | Measured from 50% of final V <sub>DD</sub> supply voltage to final RF power ± 1 dB  |                | 10                  | 20                   | μs             |
| RF path switching time                  | t <sub>SW</sub>    | From one active state to another active state transition, measured from 50% of final control voltage to final RF input power ± 1 dB |                | 2                   | 5                    | μs             |
| <b>RF Specifications</b>                |                    |   |                |                     |                      |                |
| Insertion loss, RF1, RF2, or RF3 to ANT | IL                 | 700 to 960 MHz<br>1710 to 2170 MHz<br>2300 to 2690 MHz  |                | 0.35<br>0.55<br>0.7 | 0.45<br>0.65<br>0.85 | dB<br>dB<br>dB |
| Isolation, ANT to RF1, RF2, or RF3      | ISO                | 700 to 960 MHz<br>1710 to 2170 MHz<br>2300 to 2690 MHz  | 26<br>18<br>16 | 28<br>20<br>18      |                      | dB<br>dB<br>dB |
| Isolation, RFx to RFx                   | ISO                | 700 to 960 MHz<br>1710 to 2170 MHz<br>2300 to 2690 MHz  | 22<br>18<br>15 | 21<br>18<br>14      |                      | dB<br>dB<br>dB |
| Return loss, all ports                  | RL                 | Referenced to 50 Ω, 700 to 2690 MHz   | 10             | 14                  |                      | dB             |
| <b>Large Signal Specifications</b>      |                    |   |                |                     |                      |                |
| Harmonics RF1, FR2, or RF3 to ANT       | 2fo                | fo = 700 MHz to 915 MHz,<br>P <sub>IN</sub> = +35 dBm, 50 Ω   |                | -70                 | -60                  | dBm            |
| Harmonics RF1, FR2, or RF3 to ANT       | 2fo                | fo = 700 MHz to 915 MHz,<br>P <sub>IN</sub> = +35 dBm, VSWR = 2.5:1   |                | -60                 | -45                  | dBm            |
| Harmonics RF1, FR2, or RF3 to ANT       | 2fo                | fo = 1710 MHz to 1910 MHz,<br>P <sub>IN</sub> = +33 dBm, 50 Ω   |                | -60                 | -48                  | dBm            |
| Harmonics RF1, FR2, or RF3 to ANT       | 2fo                | fo = 1710 MHz to 1910 MHz,<br>P <sub>IN</sub> = +33 dBm, VSWR = 2.5:1   |                | -50                 | -45                  | dBm            |
| Harmonics RF1, FR2, or RF3 to ANT       | 2fo                | fo = 2170 MHz to 2690 MHz,<br>P <sub>IN</sub> = +25 dBm, 50 Ω   |                | -60                 | -40                  | dBm            |
| Harmonics RF1, FR2, or RF3 to ANT       | 2fo                | fo = 2170 MHz to 2690 MHz,<br>P <sub>IN</sub> = +25 dBm, VSWR = 2.5:1   |                | -55                 | -40                  | dBm            |
| Harmonics RF1, FR2 or RF3 to ANT        | 3fo                | fo = 700 MHz to 915 MHz,<br>P <sub>IN</sub> = +35 dBm, 50 Ω   |                | -60                 | -55                  | dBm            |
| Harmonics RF1, FR2 or RF3 to ANT        | 3fo                | fo = 700 MHz to 915 MHz,<br>P <sub>IN</sub> = +35 dBm, VSWR = 2.5:1   |                | -50                 | -45                  | dBm            |
| Harmonics RF1, FR2, or RF3 to ANT       | 3fo                | fo = 1710 MHz to 1910 MHz,<br>P <sub>IN</sub> = +33 dBm, 50 Ω   |                | -60                 | -50                  | dBm            |

**Table 3. SKY13449-001 Electrical Specifications (2 of 2) (Note 1)**  
**(V<sub>DD</sub> = 2.65 V, T<sub>OP</sub> = +25 °C, Characteristic Impedance [Z<sub>0</sub>] = 50 Ω, Unless Otherwise Noted)**

| Parameter  | Symbol | Test Condition  | Min | Typical | Max  | Units |
|--|--------|---|-----|---------|------|-------|
| <b>Large Signal Specifications</b>                               |        |   |     |         |      |       |
| Harmonics RF1, RF2, or RF3 to ANT                                | 3fo    | f <sub>o</sub> = 1710 MHz to 1910 MHz,<br>P <sub>IN</sub> = +33 dBm, VSWR = 2.5:1   |     | -50     | -36  | dBm   |
| Harmonics RF1, RF2, or RF3 to ANT                                | 3fo    | f <sub>o</sub> = 2170 MHz to 2690 MHz,<br>P <sub>IN</sub> = +25 dBm, 50 Ω   |     | -60     | -42  | dBm   |
| Harmonics RF1, RF2, or RF3 to ANT                                | 3fo    | f <sub>o</sub> = 2170 MHz to 2690 MHz,<br>P <sub>IN</sub> = +25 dBm, VSWR = 2.5:1   |     | -55     | -36  | dBm   |
| Band 17 3rd Harmonic   | 3fo    | f <sub>o</sub> = 704 MHz to 716 MHz,<br>P <sub>IN</sub> = +25 dBm, 50 Ω   |     | -85     |      | dBm   |
| Band 13 2nd Harmonic   | 2fo    | f <sub>o</sub> = 777 MHz to 787 MHz,<br>P <sub>IN</sub> = +25 dBm, 50 Ω   |     | -93     |      | dBm   |
| Second order intermodulation distortion, ANT to RF1, RF2, or RF3 | IMD2   | f <sub>TX</sub> = 1950 MHz, P <sub>tx</sub> = +21dBm<br>f <sub>BLK</sub> = 190 MHz, P <sub>bl</sub> = -15 dBm<br>f <sub>IMD</sub> = 2140 MHz      |     | -108    | -100 | dBm   |
| Second order intermodulation distortion, ANT to RF1, RF2, or RF3 | IMD2   | f <sub>TX</sub> = 1950 MHz, P <sub>tx</sub> = +21 dBm<br>f <sub>BLK</sub> = 4090 MHz, P <sub>bl</sub> = -15 dBm<br>f <sub>IMD</sub> = 2140 MHz    |     | -110    | -95  | dBm   |
| Second order intermodulation distortion, ANT to RF1, RF2, or RF3 | IMD2   | f <sub>TX</sub> = 836.5 MHz, P <sub>tx</sub> = +21 dBm<br>f <sub>BLK</sub> = 45 MHz, P <sub>bl</sub> = -15 dBm<br>f <sub>IMD</sub> = 881.5 MHz    |     | -101    | -90  | dBm   |
| Second order intermodulation distortion, ANT to RF1, RF2, or RF3 | IMD2   | f <sub>TX</sub> = 836.5 MHz, P <sub>tx</sub> = +21 dBm<br>f <sub>BLK</sub> = 1718 MHz, P <sub>bl</sub> = -15 dBm<br>f <sub>IMD</sub> = 881.5 MHz  |     | -110    | -100 | dBm   |
| Second order intermodulation distortion, ANT to RF1, RF2, or RF3 | IMD2   | f <sub>TX</sub> = 2535 MHz, P <sub>tx</sub> = +21 dBm<br>f <sub>BLK</sub> = 120 MHz, P <sub>bl</sub> = -15 dBm<br>f <sub>IMD</sub> = 2655 MHz     |     | -110    | -105 | dBm   |
| Second order intermodulation distortion, ANT to RF1, RF2, or RF3 | IMD2   | f <sub>TX</sub> = 2535 MHz, P <sub>tx</sub> = +21 dBm<br>f <sub>BLK</sub> = 5190 MHz, P <sub>bl</sub> = -15 dBm<br>f <sub>IMD</sub> = 2655 MHz    |     | -100    | -85  | dBm   |
| Third order intermodulation distortion, ANT to RF1, RF2, or RF3  | IMD3   | f <sub>TX</sub> = 1950 MHz, P <sub>tx</sub> = +21 dBm<br>f <sub>BLK</sub> = 1760 MHz, P <sub>bl</sub> = -15 dBm<br>f <sub>IMD</sub> = 2140 MHz    |     | -110    | -105 | dBm   |
| Third order intermodulation distortion, ANT to RF1, RF2, or RF3  | IMD3   | f <sub>TX</sub> = 836.5 MHz, P <sub>tx</sub> = +21 dBm<br>f <sub>BLK</sub> = 791.5 MHz, P <sub>bl</sub> = -15 dBm<br>f <sub>IMD</sub> = 881.5 MHz |     | -110    | -105 | dBm   |
| Third order intermodulation distortion, ANT to RF1, RF2, or RF3  | IMD3   | f <sub>TX</sub> = 2535 MHz, P <sub>tx</sub> = +21 dBm<br>f <sub>BLK</sub> = 2415 MHz, P <sub>bl</sub> = -15 dBm<br>f <sub>IMD</sub> = 2655 MHz    |     | -105    | -85  | dBm   |

**Note 1:** Performance is guaranteed only under the conditions listed in this table.

**Table 4. SKY13449-001 Truth Table (Note 1)**

| Logic State | V1 | V2 | Active Path |
|-------------|----|----|-------------|
| 1           | 0  | 1  | ANT-RF2     |
| 2           | 1  | 0  | ANT-RF3     |
| 3           | 1  | 1  | ANT-RF1     |

**Note 1:** 0 indicates V1, V2 = V<sub>CTL\_L</sub> (0 to 0.4 V)  
 1 indicates V1, V2 = V<sub>CTL\_H</sub> (1.3 to 3.0 V)

### Evaluation Board Description

The SKY13449-001 Evaluation Board is used to test the performance of the SKY13449-001 SP3T Switch. An Evaluation Board schematic diagram is shown in Figure 3. An assembly drawing for the Evaluation Board is shown in Figure 4. The PCB layout footprint is shown in Figure 5.

### Package Dimensions

Package dimensions for the SKY13449-001 die are shown in Figure 6, and tape and reel dimensions are provided in Figure 7.

### Package and Handling Information

Instructions on the shipping container label regarding exposure to moisture after the container seal is broken must be followed. Otherwise, problems related to moisture absorption may occur when the part is subjected to high temperature during solder assembly.

The SKY13449-001 is rated to Moisture Sensitivity Level 1 (MSL1) at 260 °C. It can be used for lead or lead-free soldering. For additional information, refer to the Skyworks Application Note, *Wafer Level Chip Scale Packages: SMT Process Guidelines and Handling Considerations*, document number 201676.

Care must be taken when attaching this product, whether it is done manually or in a production solder reflow environment. Production quantities of this product are shipped in a standard tape and reel format.

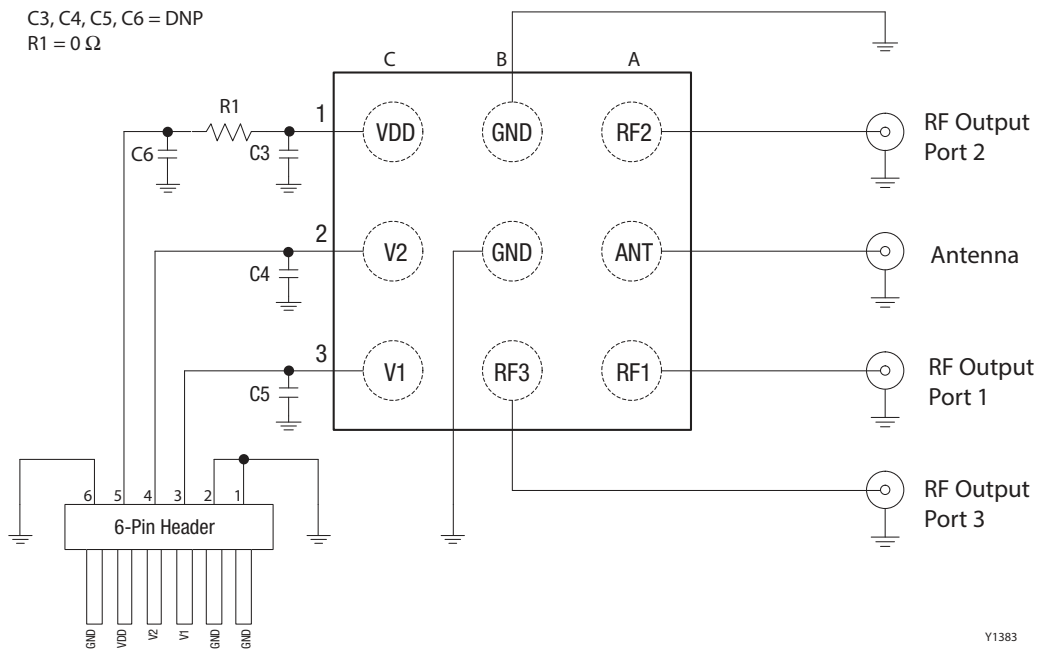
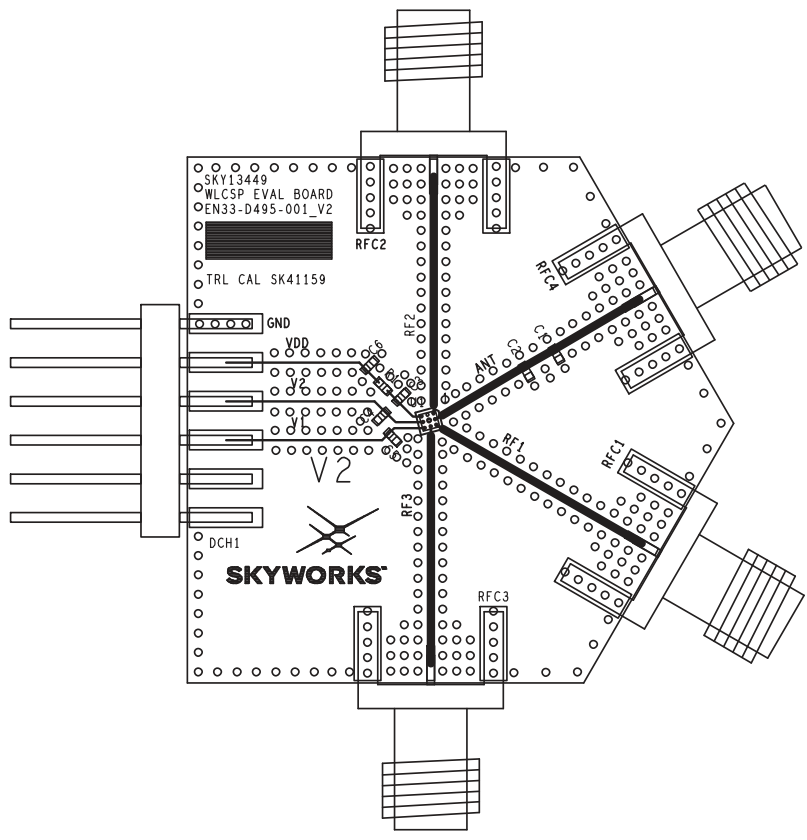
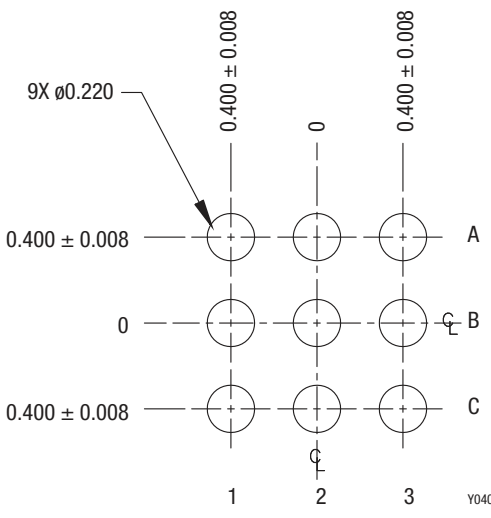

Figure 3. SKY13449-001 Evaluation Board Schematic



Y0016

Figure 4. SKY13449-001 Evaluation Board Assembly Diagram



Y0406

Figure 5. SKY13449-001 PCB Layout Footprint (9-Bump WLCSP)

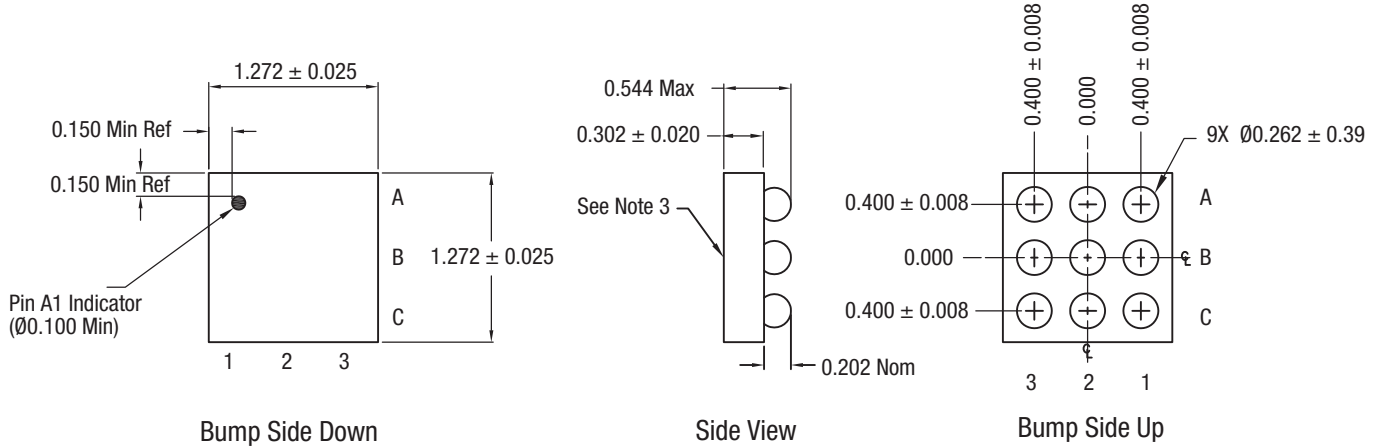

Notes:

1. All dimensions are in millimeters unless otherwise specified.
2. Marking shown is for package orientation reference only.
3. Includes backside coating.
4. Ball height tolerance is  $\pm 10\%$  of nominal ball height.

ts241

Figure 6. SKY13449-001 Package Dimensions

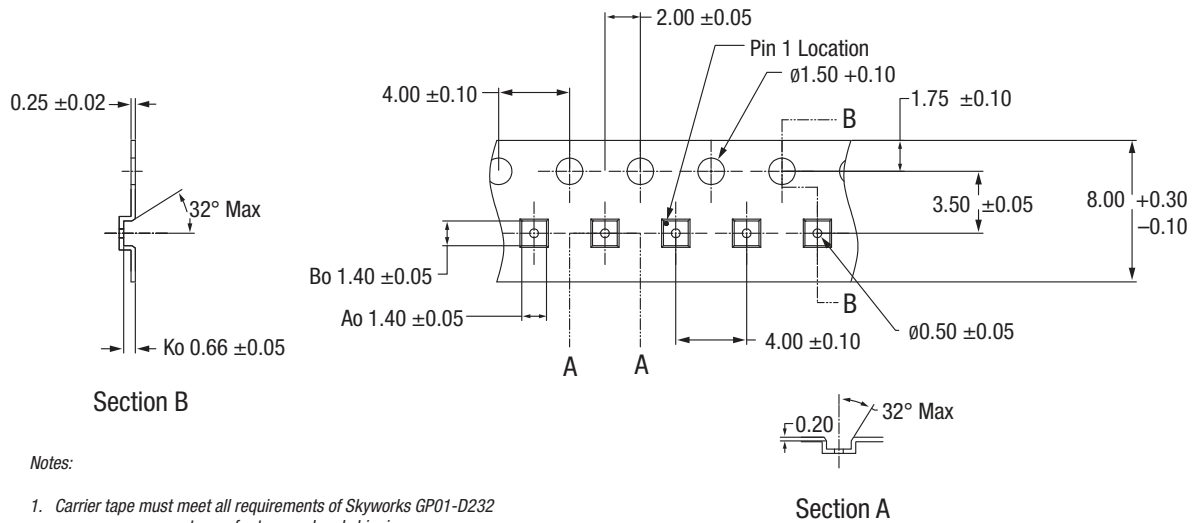

Notes:

1. Carrier tape must meet all requirements of Skyworks GP01-D232 procurement spec for tape and reel shipping.
2. Carrier tape material: black conductive polycarbonate.
3. Cover tape material: transparent conductive.
4. ESD surface resistivity must meet all ESD requirements of Skyworks specified on GP01-D232.
5. 10-sprocket hole pitch cumulative tolerance:  $\pm 0.20$  mm.
6. Pocket position relative to sprocket hole measured as true position of pocket.
7. Ao and Bo measured on plane 0.30 mm above the bottom of the pocket.
8. All dimensions are in millimeters.

Y1384

Figure 7. SKY13449-001 Tape and Reel Dimensions

## Ordering Information

| Model Name  | Manufacturing Part Number | Evaluation Board Part Number |
|---|---------------------------|------------------------------|
| SKY13449-001: 0.5 to 3.0 GHz SP3T Switch in a WLCSP Package | SKY13449-001              | SKY13449-001-EVB             |

Copyright © 2014 Skyworks Solutions, Inc. All Rights Reserved.

Information in this document is provided in connection with Skyworks Solutions, Inc. ("Skyworks") products or services. These materials, including the information contained herein, are provided by Skyworks as a service to its customers and may be used for informational purposes only by the customer. Skyworks assumes no responsibility for errors or omissions in these materials or the information contained herein. Skyworks may change its documentation, products, services, specifications or product descriptions at any time, without notice. Skyworks makes no commitment to update the materials or information and shall have no responsibility whatsoever for conflicts, incompatibilities, or other difficulties arising from any future changes.

No license, whether express, implied, by estoppel or otherwise, is granted to any intellectual property rights by this document. Skyworks assumes no liability for any materials, products or information provided hereunder, including the sale, distribution, reproduction or use of Skyworks products, information or materials, except as may be provided in Skyworks Terms and Conditions of Sale.

THE MATERIALS, PRODUCTS AND INFORMATION ARE PROVIDED "AS IS" WITHOUT WARRANTY OF ANY KIND, WHETHER EXPRESS, IMPLIED, STATUTORY, OR OTHERWISE, INCLUDING FITNESS FOR A PARTICULAR PURPOSE OR USE, MERCHANTABILITY, PERFORMANCE, QUALITY OR NON-INFRINGEMENT OF ANY INTELLECTUAL PROPERTY RIGHT; ALL SUCH WARRANTIES ARE HEREBY EXPRESSLY DISCLAIMED. SKYWORKS DOES NOT WARRANT THE ACCURACY OR COMPLETENESS OF THE INFORMATION, TEXT, GRAPHICS OR OTHER ITEMS CONTAINED WITHIN THESE MATERIALS. SKYWORKS SHALL NOT BE LIABLE FOR ANY DAMAGES, INCLUDING BUT NOT LIMITED TO ANY SPECIAL, INDIRECT, INCIDENTAL, STATUTORY, OR CONSEQUENTIAL DAMAGES, INCLUDING WITHOUT LIMITATION, LOST REVENUES OR LOST PROFITS THAT MAY RESULT FROM THE USE OF THE MATERIALS OR INFORMATION, WHETHER OR NOT THE RECIPIENT OF MATERIALS HAS BEEN ADVISED OF THE POSSIBILITY OF SUCH DAMAGE.

Skyworks products are not intended for use in medical, lifesaving or life-sustaining applications, or other equipment in which the failure of the Skyworks products could lead to personal injury, death, physical or environmental damage. Skyworks customers using or selling Skyworks products for use in such applications do so at their own risk and agree to fully indemnify Skyworks for any damages resulting from such improper use or sale.

Customers are responsible for their products and applications using Skyworks products, which may deviate from published specifications as a result of design defects, errors, or operation of products outside of published parameters or design specifications. Customers should include design and operating safeguards to minimize these and other risks. Skyworks assumes no liability for applications assistance, customer product design, or damage to any equipment resulting from the use of Skyworks products outside of stated published specifications or parameters.

Skyworks and the Skyworks symbol are trademarks or registered trademarks of Skyworks Solutions, Inc., in the United States and other countries. Third-party brands and names are for identification purposes only, and are the property of their respective owners. Additional information, including relevant terms and conditions, posted at [www.skyworksinc.com](http://www.skyworksinc.com), are incorporated by reference.