

Type ANM-W Automotive Blade Fuse Miniature with Lead Wire



www.optifuse.com (619) 593-5050

Specifications:

- Voltage: 32VDC
- Amperage: 10A, 15A, 20A
- Body: PA 66
- Wire: 16 or 18 AWG Red Wire
- Terminals: Zinc alloy
- Designed to meet SAE and ISO 8820 Standards.
- Interrupt Rating – 1000A @ 32 VDC

Part Number:

ANM-W-XXA-YYZ

Where **XX** = Amperage (10, 15, 20)

YY = Wire Gauge (16, 18 AWG)

Z = Wire Color (Standard: **R**= Red)

Other colors available – special order

Time Characteristics:		
% of Rated Current	Min Hold Time	Max Hold Time
110%	100h	~
135%	~	1800s
200%	~	5s

Part Number	Amperage	Body Color	Wire Gauge	Max. Extended Circuit
ANM-W-10A-16R	10A	Red	16 AWG	10A
ANM-W-15A-16R	15A	Blue	16 AWG	10A
ANM-W-20A-16R	20A	Yellow	16 AWG	10A
ANM-W-10A-18R	10A	Red	18 AWG	5A
ANM-W-15A-18R	15A	Blue	18 AWG	5A
ANM-W-20A-18R	20A	Yellow	18 AWG	5A

Mechanical Dimensions: Inches [mm]

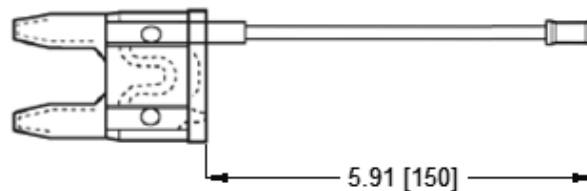
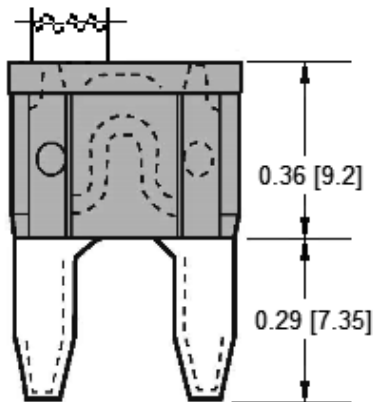
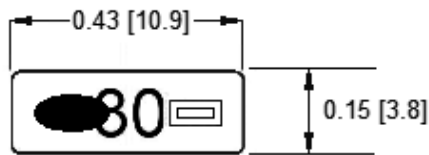

Warning:



-Operation beyond the specified maximum ratings or improper use may result in damage and possible electrical arcing and/or flame.

-Avoid contact of device with chemical solvent. Prolonged contact will damage the device performance.

Note: All specifications subject to change without notice.

Rev A 06/2015 - Page: 1/2
Code H02-01H

**Type ANM-W
Automotive Blade Fuse
Miniature with Lead Wire**



www.optifuse.com (619) 593-5050

Time Current Curve

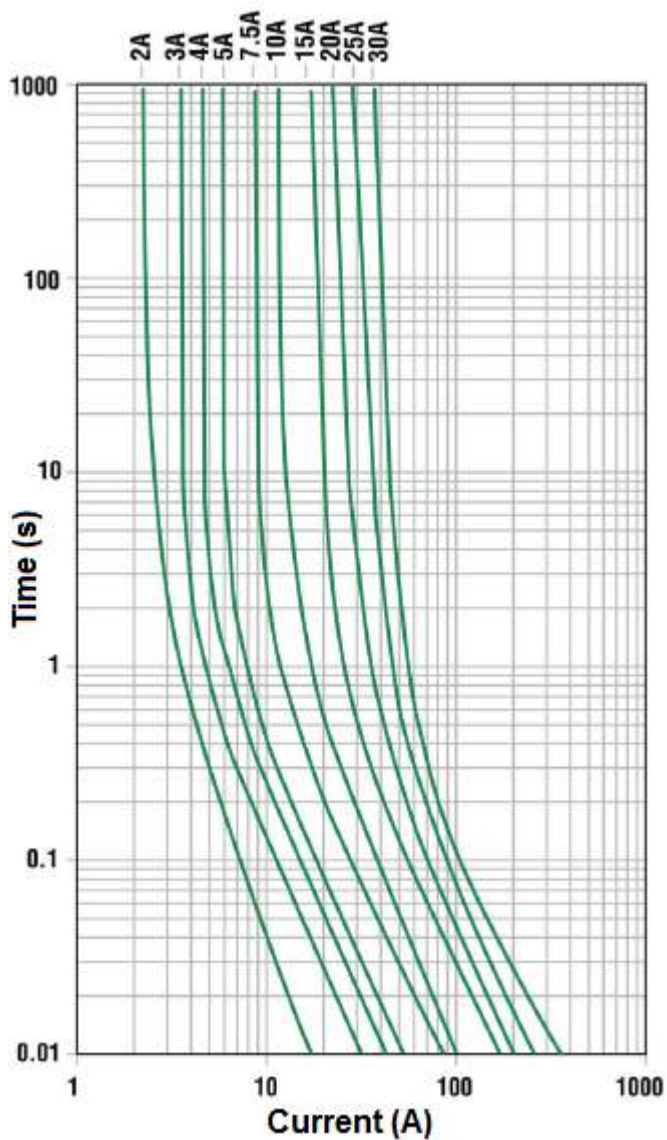

Note: All specifications subject to change without notice.

Rev A 06/2015 - Page: 2/2
Code H02-01H