

# FL7760LED1GEVK

## 3W SPI Controllable LED Driver Evaluation Board User's Manual

### OVERVIEW

This manual covers the specification, theory of operation, testing and construction of the FL7760LED1GEVK demonstration kit. The FL7760 kit demonstrates a 1 A buck LED driver intended for a single high-power LED. The SPI (Serial Peripheral Interface) bus does both analog and PWM dimming. The kit includes a load/SPI interface board to facilitate operation of the driver. The driver can be driven independently from any SPI controller. The nominal input voltage is 12 V.

**Table 1. SPECIFICATIONS**

Input Voltage	10.8 V dc – 13.2 V dc	
Output Voltage	2.5 V dc – 5.0 V dc	
Output Current	1 A	Max
Output Ripple	40 mA	P–P
Efficiency	85%	Typ.
Switching Frequency	200 kHz	
Rise/Fall Time	< 20 $\mu$ s	
Dimming Interface	SPI	
Dimming Resolution	8 bits	
PCB Size	30 mm $\times$ 30 mm	

The key features of this demo kit include:

- Low Parts Count
- Single Sided Assembly
- Small Footprint
- Very Fast Rise/Fall Times
- SPI Dimming Control for Analog and PWM Dimming
- 12 V Operation
- Integrated Thermal Shutdown and UVLO

### THEORY OF OPERATION

#### Power Stage

The power stage is a CCM inverted buck converter. The output inductor sets the switching frequency because the control operates in hysteretic control mode. The peak and valley current are fixed percentages of the current reference. This fixes the inductor ripple current and eliminates the need for closed loop compensation. A novel high side current sense enables direct accurate control of the output current.



ON Semiconductor®

[www.onsemi.com](http://www.onsemi.com)

### EVAL BOARD USER'S MANUAL

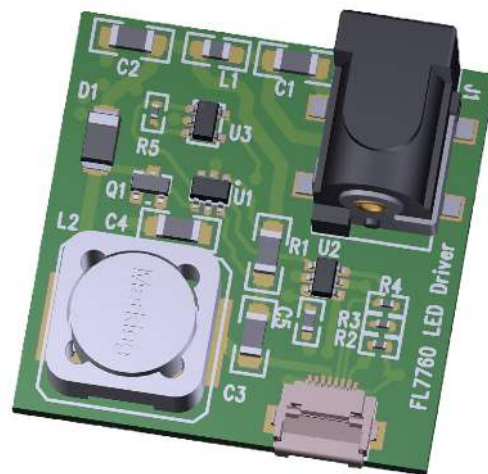

**FL7760LED1GEVK  
Evaluation Board**

# FL7760LED1GEVK

## HV Start

The FL7760 supplies its own Vcc power greatly simplifying implementation. The input voltage range is 8 V – 70V. The internal Vcc regulates to 5 V ± 10%. The internal Vcc supplies a 3.3 V LDO for powering the DAC. The regulator and DAC draw less than 1mA combined.

## Dimming

The FL7760 dim input controls both amplitude and on/off control. This makes the dim interface controllable by analog, PWM, or both at the same time. The DAC has an output range of 0 V – 3.3 V for 8 bits of resolution. A dim signal below 0.5 V turns off the output and a dim signal above 3 V is 100% output.

## Protection

### Thermal Protection

The thermal protection is built into the FL7760 and shuts down the FL7760 when the die temperature exceeds 150°C.

## OVP

The output voltage is inherently limited to be less than or equal to Vin. As such, no OVP is required due this inherent limitation.

## Load Board Operation

The load board connects to the LED driver via an 8 conductor FPC cable. The FPC cable makes a simple and convenient interconnection. The load board serves 2 major functions: 1) provide an easy connection to an LED load 2) provide a USB–SPI bridge for computer control of the LED driver.

The daughter card on the load has a mini USB–A connection for attachment to your computer. See the test procedure for details of the setup of the SPI terminal application.

## SCHEMATIC

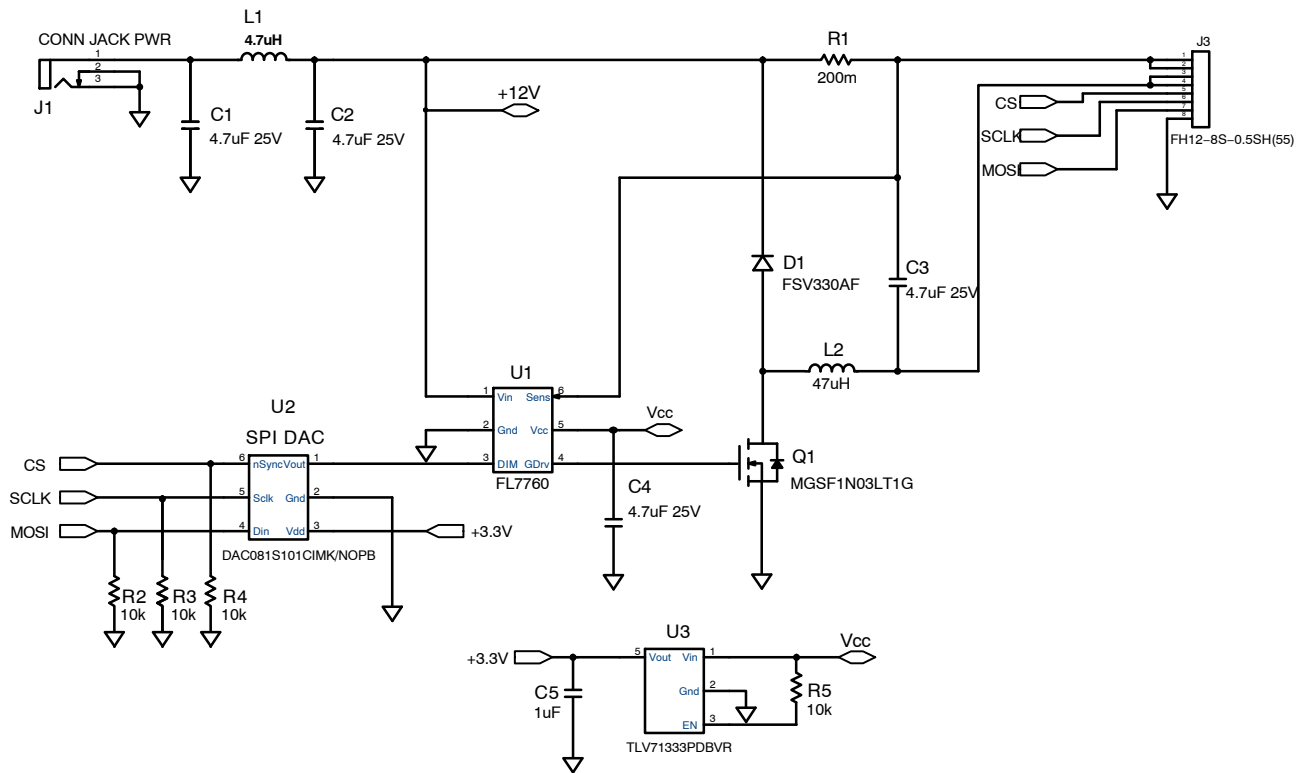

Figure 1. LED Driver Circuit



# FL7760LED1GEVK

## TEST PROCEDURE

### Equipment Needed

DC Source – 12 V ± 5% @ 1 A

2 – DC Voltmeter – 300 V dc minimum 0.1% accuracy or better

2 – DC Ammeter – 1 A dc minimum 0.1% accuracy or better

LED Load – 2.5 V – 5.0 V @ 1.0 A

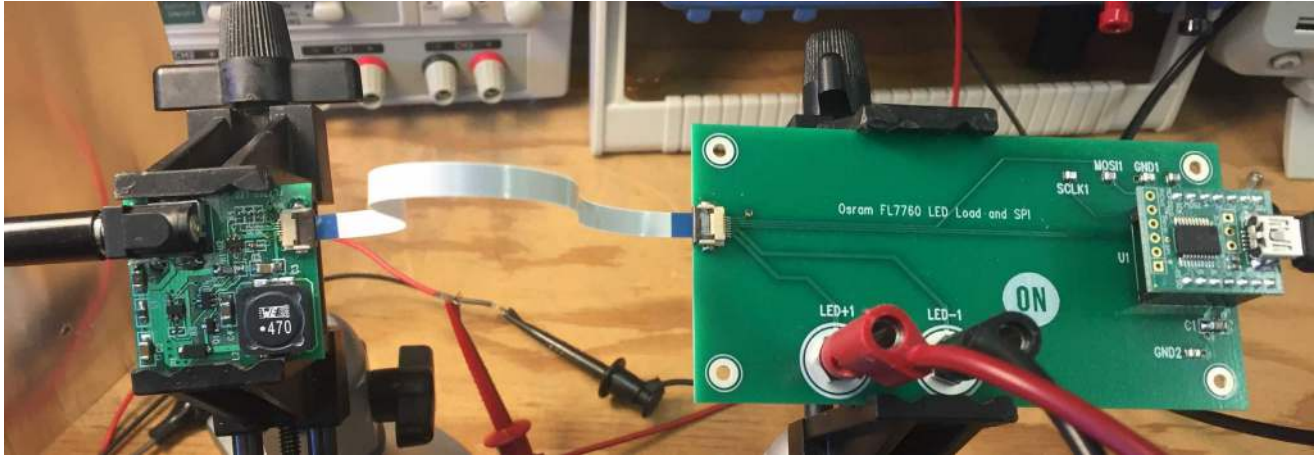

Figure 3. Test Set Up

### The Connections

1. Connect the LED load board to the LED driver using the FPC cable provided in the kit.
2. Connect red (+) and black (-) leads through the ammeter to the LED load.
3. Connect a 12 V dc source to the input power connector.

NOTE: Unless otherwise specified, all voltage measurements are taken at the terminals of the UUT.

### Functional Test Procedure

1. Set the LED Load for 3.5 V output.
2. Set the input voltage to 12 V.
3. Measure input voltage and current.
4. Measure output voltage and current.

### Regulation

See Table 3.

Table 3. REGULATION

DAC Data	I <sub>out</sub> Target	Output Current	Output Voltage	Input Voltage	Input Current
00 00	0 A				
0F F0	1 A ± 5%				
07 00	0.5 A ± 5%				

$$\text{Efficiency} = \frac{V_{\text{out}} \times I_{\text{out}}}{V_{\text{in}} \times I_{\text{in}}} \times 100\%$$

# FL7760LED1GEVK

## TEST DATA

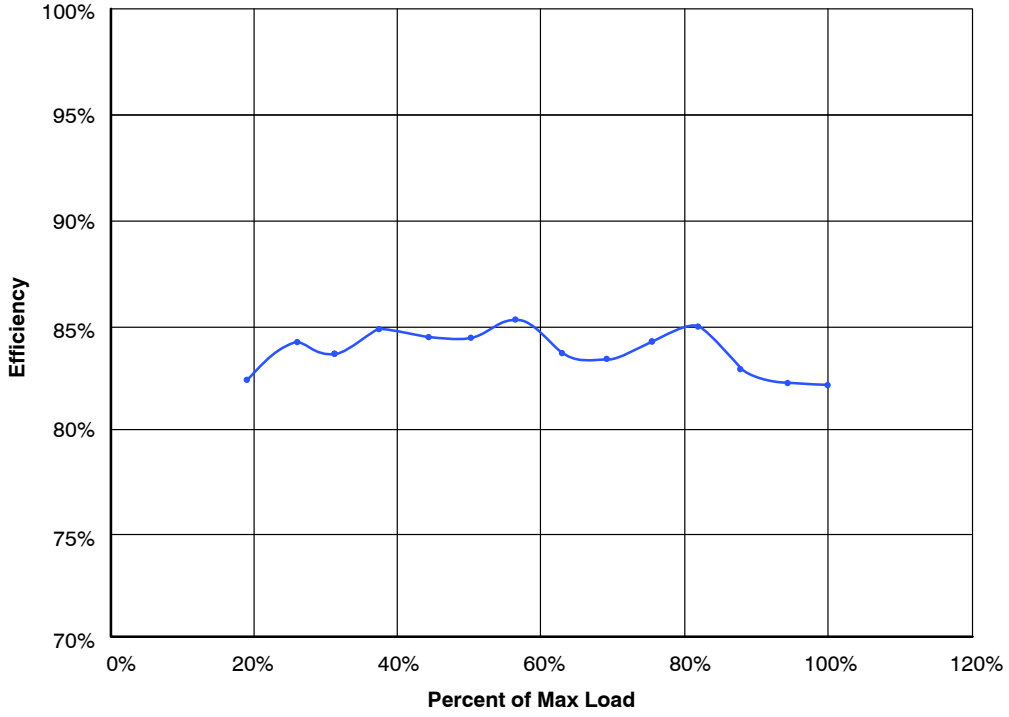

Figure 4. Efficiency

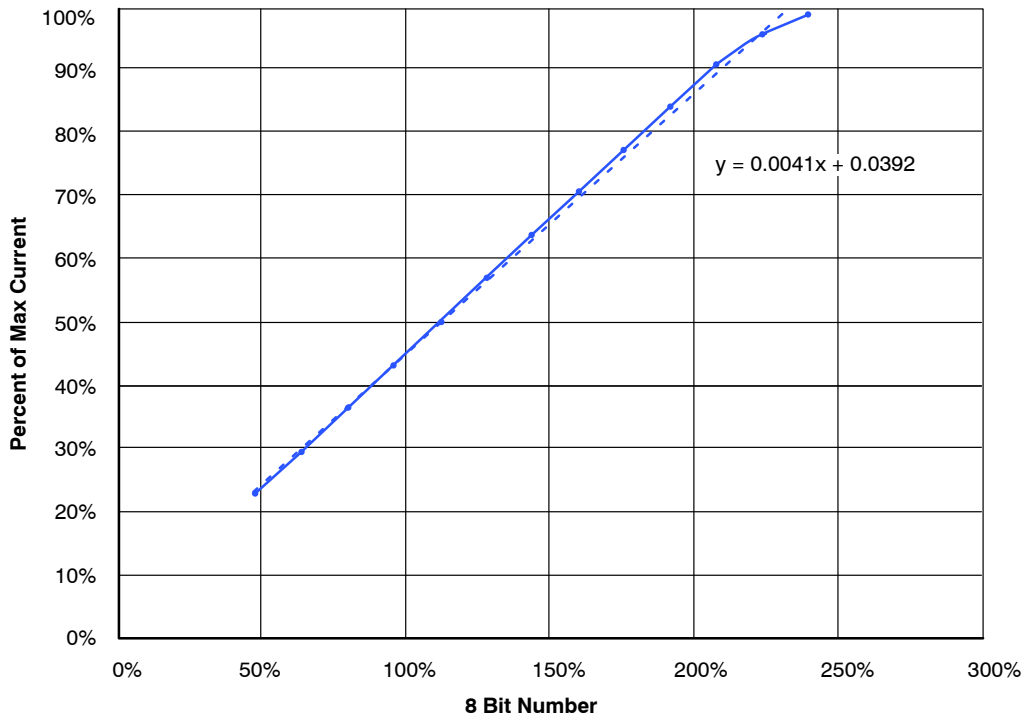

Figure 5. Dim Curve

# FL7760LED1GEVK

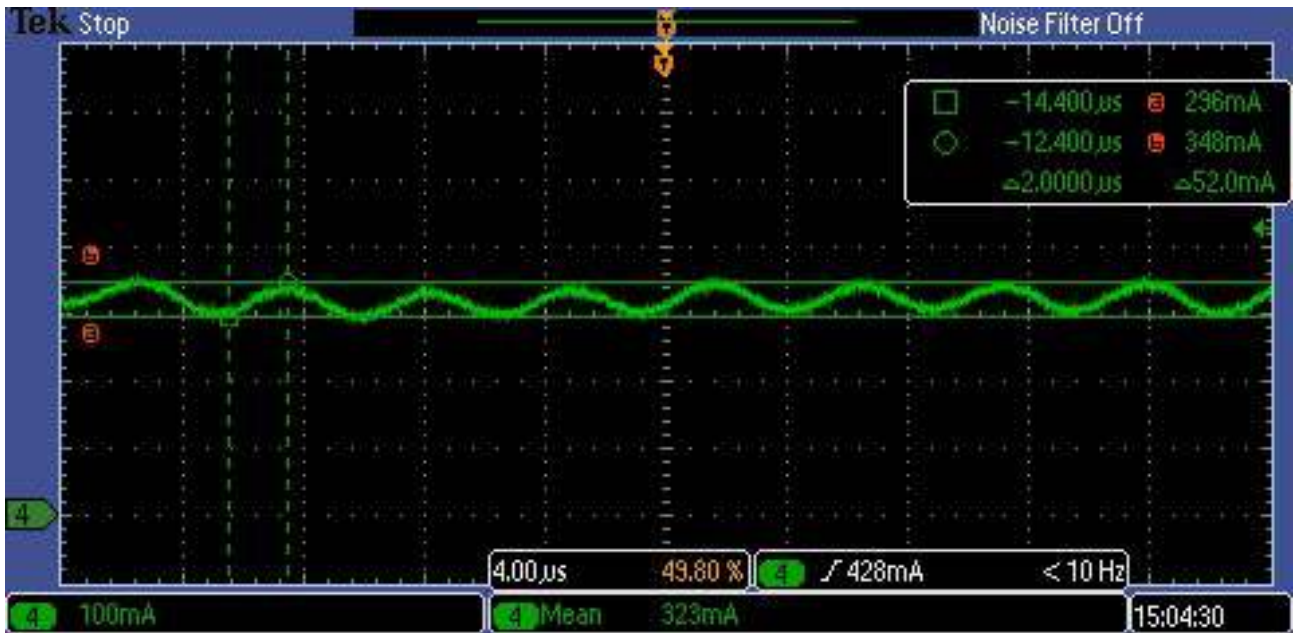

Figure 6. Input Current Ripple

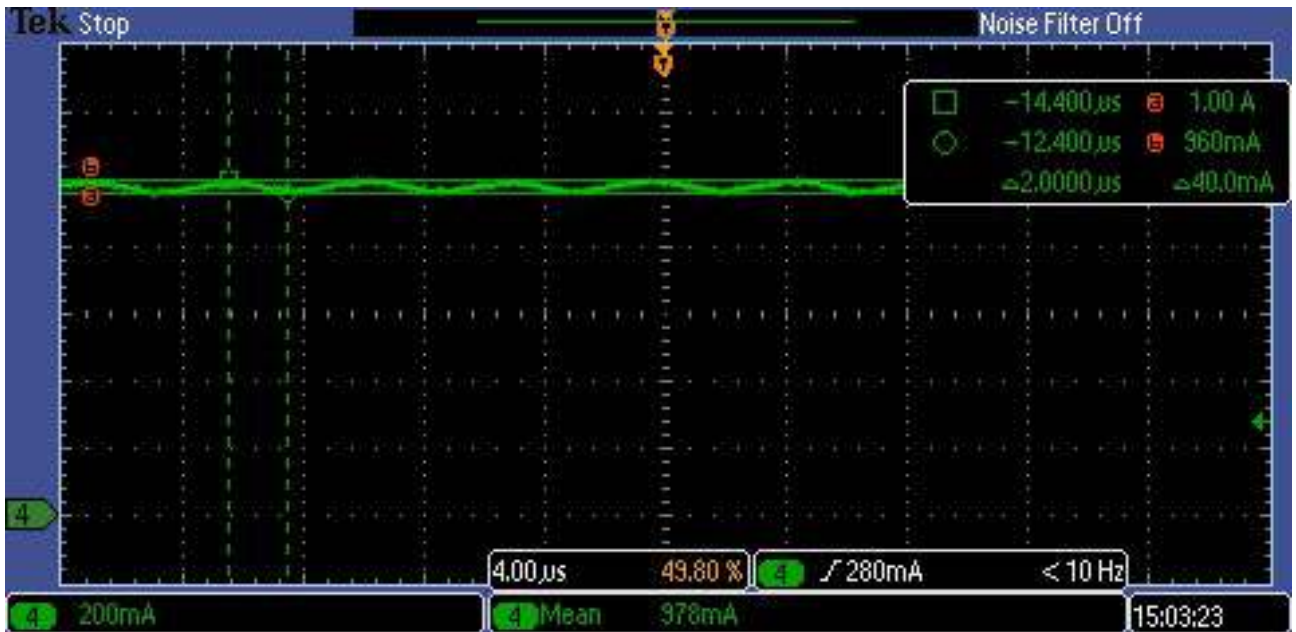

Figure 7. Output Current Ripple

# FL7760LED1GEVK

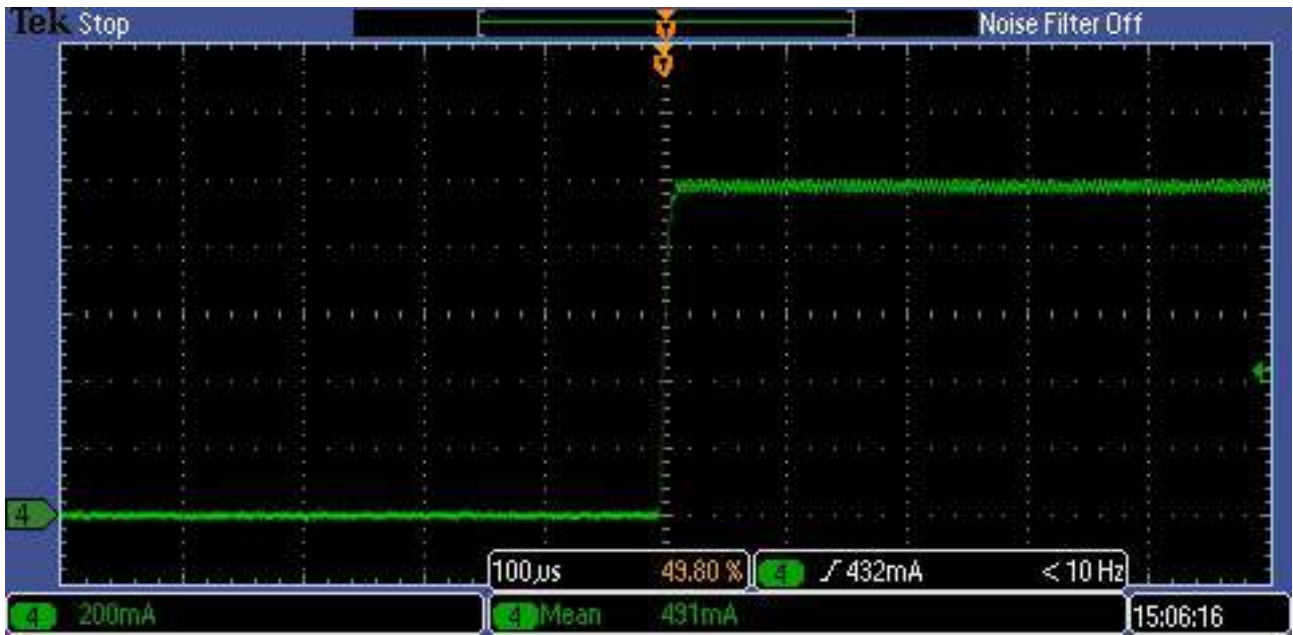

Figure 8. Input Current Rise

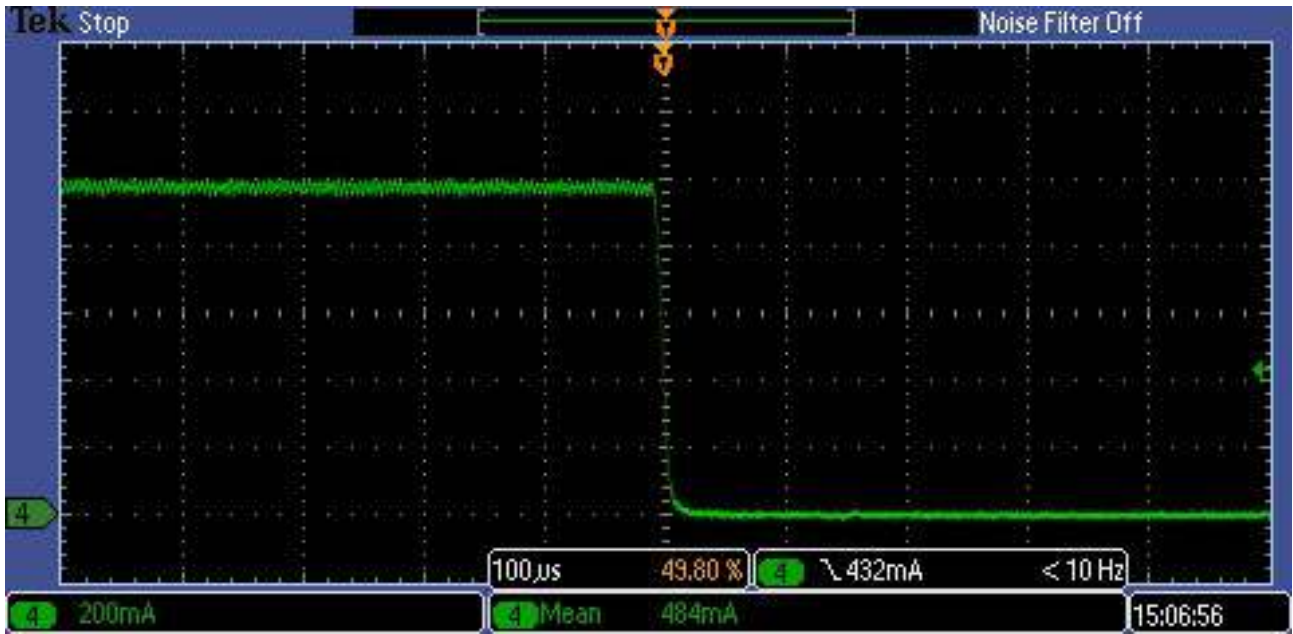

Figure 9. Output Current Fall

# FL7760LED1GEVK

## THERMAL IMAGE

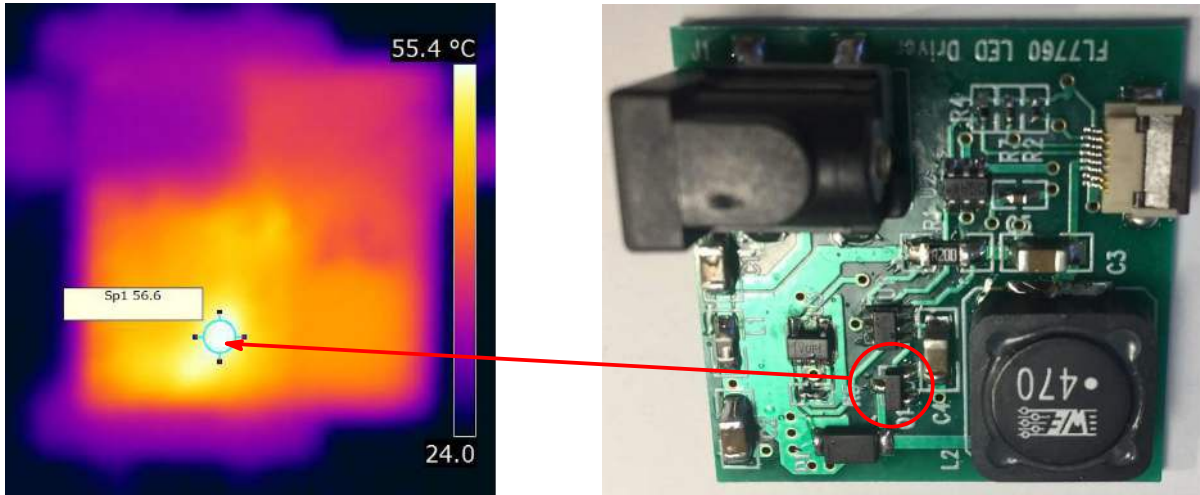

Figure 10.



**onsemi**, **Onsemi**, and other names, marks, and brands are registered and/or common law trademarks of Semiconductor Components Industries, LLC dba "**onsemi**" or its affiliates and/or subsidiaries in the United States and/or other countries. **onsemi** owns the rights to a number of patents, trademarks, copyrights, trade secrets, and other intellectual property. A listing of **onsemi**'s product/patent coverage may be accessed at [www.onsemi.com/site/pdf/Patent-Marking.pdf](http://www.onsemi.com/site/pdf/Patent-Marking.pdf). **onsemi** is an Equal Opportunity/Affirmative Action Employer. This literature is subject to all applicable copyright laws and is not for resale in any manner.

The evaluation board/kit (research and development board/kit) (hereinafter the "board") is not a finished product and is not available for sale to consumers. The board is only intended for research, development, demonstration and evaluation purposes and will only be used in laboratory/development areas by persons with an engineering/technical training and familiar with the risks associated with handling electrical/mechanical components, systems and subsystems. This person assumes full responsibility/liability for proper and safe handling. Any other use, resale or redistribution for any other purpose is strictly prohibited.

**THE BOARD IS PROVIDED BY ONSEMI TO YOU "AS IS" AND WITHOUT ANY REPRESENTATIONS OR WARRANTIES WHATSOEVER. WITHOUT LIMITING THE FOREGOING, ONSEMI (AND ITS LICENSORS/SUPPLIERS) HEREBY DISCLAIMS ANY AND ALL REPRESENTATIONS AND WARRANTIES IN RELATION TO THE BOARD, ANY MODIFICATIONS, OR THIS AGREEMENT, WHETHER EXPRESS, IMPLIED, STATUTORY OR OTHERWISE, INCLUDING WITHOUT LIMITATION ANY AND ALL REPRESENTATIONS AND WARRANTIES OF MERCHANTABILITY, FITNESS FOR A PARTICULAR PURPOSE, TITLE, NON-INFRINGEMENT, AND THOSE ARISING FROM A COURSE OF DEALING, TRADE USAGE, TRADE CUSTOM OR TRADE PRACTICE.**

**onsemi** reserves the right to make changes without further notice to any board.

You are responsible for determining whether the board will be suitable for your intended use or application or will achieve your intended results. Prior to using or distributing any systems that have been evaluated, designed or tested using the board, you agree to test and validate your design to confirm the functionality for your application. Any technical, applications or design information or advice, quality characterization, reliability data or other services provided by **onsemi** shall not constitute any representation or warranty by **onsemi**, and no additional obligations or liabilities shall arise from **onsemi** having provided such information or services.

**onsemi** products including the boards are not designed, intended, or authorized for use in life support systems, or any FDA Class 3 medical devices or medical devices with a similar or equivalent classification in a foreign jurisdiction, or any devices intended for implantation in the human body. You agree to indemnify, defend and hold harmless **onsemi**, its directors, officers, employees, representatives, agents, subsidiaries, affiliates, distributors, and assigns, against any and all liabilities, losses, costs, damages, judgments, and expenses, arising out of any claim, demand, investigation, lawsuit, regulatory action or cause of action arising out of or associated with any unauthorized use, even if such claim alleges that **onsemi** was negligent regarding the design or manufacture of any products and/or the board.

This evaluation board/kit does not fall within the scope of the European Union directives regarding electromagnetic compatibility, restricted substances (RoHS), recycling (WEEE), FCC, CE or UL, and may not meet the technical requirements of these or other related directives.

FCC WARNING – This evaluation board/kit is intended for use for engineering development, demonstration, or evaluation purposes only and is not considered by **onsemi** to be a finished end product fit for general consumer use. It may generate, use, or radiate radio frequency energy and has not been tested for compliance with the limits of computing devices pursuant to part 15 of FCC rules, which are designed to provide reasonable protection against radio frequency interference. Operation of this equipment may cause interference with radio communications, in which case the user shall be responsible, at its expense, to take whatever measures may be required to correct this interference.

**onsemi** does not convey any license under its patent rights nor the rights of others.

LIMITATIONS OF LIABILITY: **onsemi** shall not be liable for any special, consequential, incidental, indirect or punitive damages, including, but not limited to the costs of requalification, delay, loss of profits or goodwill, arising out of or in connection with the board, even if **onsemi** is advised of the possibility of such damages. In no event shall **onsemi**'s aggregate liability from any obligation arising out of or in connection with the board, under any theory of liability, exceed the purchase price paid for the board, if any.

The board is provided to you subject to the license and other terms per **onsemi**'s standard terms and conditions of sale. For more information and documentation, please visit [www.onsemi.com](http://www.onsemi.com).

## ADDITIONAL INFORMATION

### TECHNICAL PUBLICATIONS:

Technical Library: [www.onsemi.com/design/resources/technical-documentation](http://www.onsemi.com/design/resources/technical-documentation)  
onsemi Website: [www.onsemi.com](http://www.onsemi.com)

ONLINE SUPPORT: [www.onsemi.com/support](http://www.onsemi.com/support)

For additional information, please contact your local Sales Representative at [www.onsemi.com/support/sales](http://www.onsemi.com/support/sales)