

FEATURES

- * High input-output isolation voltage
($V_{iso} = 5,000V_{rms}$)
- * Current transfer ratio
(CTR : MIN. 10% at $I_F = 10mA$, $V_{CE} = 10V$)
- * Dual-in-line package :
H11A1, H11A2, H11A3, H11A4, H11A5
- * Wide lead spacing package :
H11A1M, H11A2M, H11A3M, H11A4M, H11A5M
- * Surface mounting package :
H11A1S, H11A2S, H11A3S, H11A4S, H11A5S
- * Tape and reel packaging :
(TYPE I) H11A1S-TA, H11A2S-TA, H11A3S-TA, H11A4S-TA, H11A5S-TA
(TYPE II) H11A1S-TA1, H11A2S-TA1, H11A3S-TA1, H11A4S-TA1, H11A5S-TA1
- * UL approved (No. E113898)
- * FIMKO approved (No. 209049)
- * NEMKO approved (No. P99102464)
- * DEMKO approved (No. 99-04182)
- * SEMKO approved (No. 9943380 / 01-20)
- * VDE approved (No. 094722)
- * CSA approve in progress

OUTLINE DIMENSIONS

Dual-in-line package:

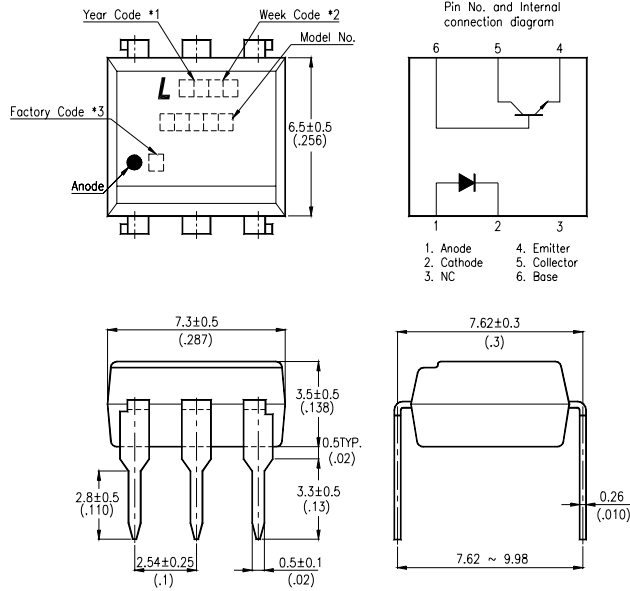

Wide lead spacing package :

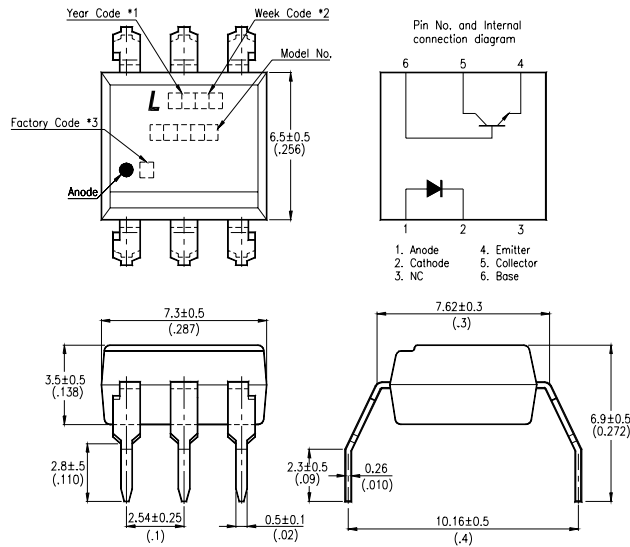

- *1. Year date code.
- *2. 2-digit work week.
- *3. Factory identification mark shall be marked (Z : Taiwan, Y : Thailand).
- *4. Model No.: H11A1, H11A2, H11A3, H11A4, H11A5

OUTLINE DIMENSIONS

Surface mounting package :

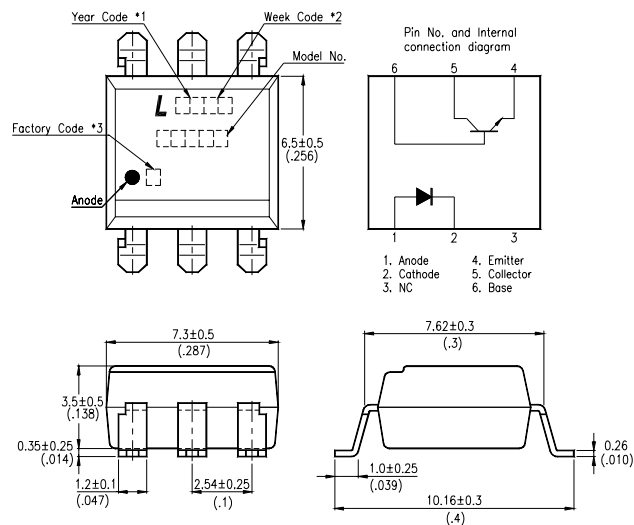

- *1. Year date code.
- *2. 2-digit work week.
- *3. Factory identification mark shall be marked (Z : Taiwan, Y : Thailand).
- *4. Model No.: H11A1, H11A2, H11A3, H11A4, H11A5

TAPING DIMENSIONS

Tape and reel packaging (TYPE I):

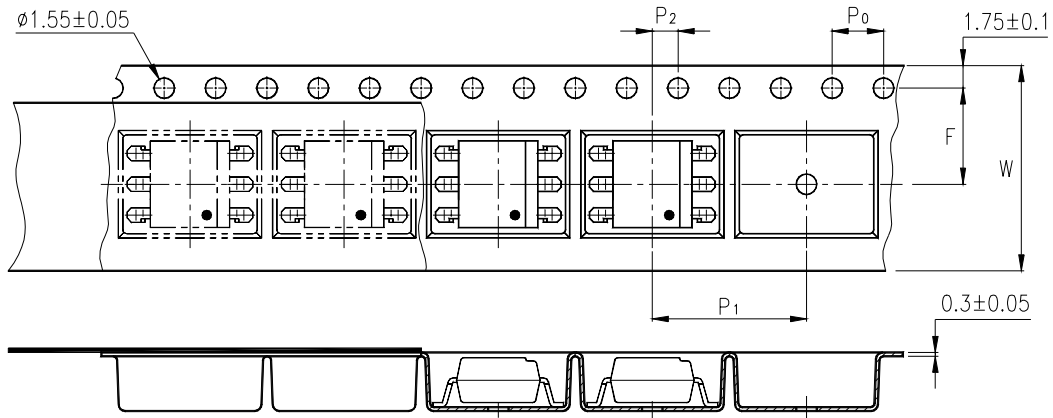

Tape and reel packaging (TYPE II):

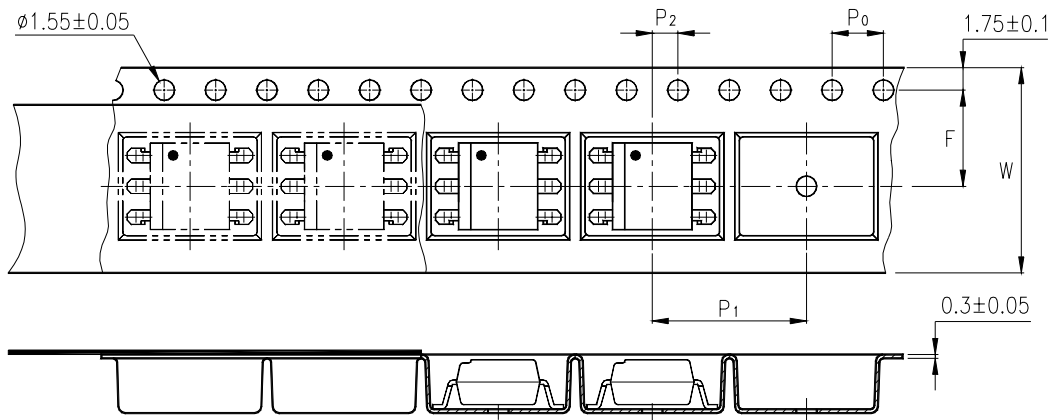

Description	Symbol	Dimensions in mm (inches)
Tape wide	W	16 ± 0.3 (.63)
Pitch of sprocket holes	P ₀	4 ± 0.1 (.15)
Distance of compartment	F	7.5 ± 0.1 (.295)
Distance of compartment to compartment	P ₁	2 ± 0.1 (.079)
Distance of compartment to compartment	P ₂	12 ± 0.1 (.472)

ABSOLUTE MAXIMUM RATING

(Ta = 25°C)

PARAMETER		SYMBOL	RATING	UNIT
INPUT	Forward Current	I _F	60	mA
	Reverse Voltage	V _R	6	V
	Power Dissipation	P	100	mW
OUTPUT	Collector - Emitter Voltage	V _{CEO}	30	V
	Emitter - Collector Voltage	V _{ECO}	7	V
	Collector - Base Voltage	V _{CBO}	70	V
	Collector Current	I _C	150	mA
	Collector Power Dissipation	P _C	150	mW
Total Power Dissipation		P _{tot}	250	mW
*1	Isolation Voltage	V _{iso}	5,000	V _{rms}
Operating Temperature		T _{opr}	-55 ~ +100	°C
Storage Temperature		T _{stg}	-55 ~ +150	°C
*2	Soldering Temperature	T _{sol}	260	°C

*1. AC For 1 Minute, R.H. = 40 ~ 60%

Isolation voltage shall be measured using the following method.

- (1) Short between anode and cathode on the primary side and between collector, emitter and base on the secondary side.
- (2) The isolation voltage tester with zero-cross circuit shall be used.
- (3) The waveform of applied voltage shall be a sine wave.

*2. For 10 Seconds

ELECTRICAL - OPTICAL CHARACTERISTICS

(Ta = 25°C)

PARAMETER		SYMBOL	MIN.	TYP.	MAX.	UNIT	CONDITIONS	
INPUT	Forward Voltage	V _F	—	1.2	1.5	V	I _F =10mA	
	Reverse Current	I _R	—	—	10	μA	V _R =6V	
	Terminal Capacitance	C _t	—	18	—	pF	V=0, f=1MHz	
OUTPUT	Collector Dark Current	I _{CEO}	—	—	50	nA	V _{CE} =10V, I _F =0	
	Collector-Emitter Breakdown Voltage	BV _{CEO}	30	—	—	V	I _C =0.1mA I _F =0	
	Emitter-Collector Breakdown Voltage	BV _{ECO}	7	—	—	V	I _E =10μA I _F =0	
	Collector-Base Breakdown Voltage	BV _{CBO}	70	—	—	V	I _C =0.1mA I _F =0	
	Collector-Emitter Capacitance	C _{CE}	—	12	—	pF	V=0V, f=1MHz	
	Collector-Base Capacitance	C _{CB}	—	17	—	pF	V _{CB} =0V, f=1MHz	
	Emitter-Base Capacitance	C _{EB}	—	25	—	pF	V _{EB} =0V, f=1MHz	
TRANSFER CHARACTERISTICS	* Current Transfer Ratio	H11A1	CTR	50	—	—	%	I _F =10mA V _{CE} =10V
		H11A2		20	—	—		
		H11A3		20	—	—		
		H11A4		10	—	—		
		H11A5		30	—	—		
	Collector-Emitter Saturation Voltage	V _{CE(sat)}	—	0.15	0.4	V	I _F =10mA I _C =0.5mA	
	Isolation Resistance	R _{iso}	100	—	—	GΩ	DC500V 40 ~ 60% R.H.	
	Floating Capacitance	C _f	—	0.3	—	pF	V=0, f=1MHz	
	Response Time (Rise)	t _r	—	2.8	—	μs	V _{CC} =10V, I _F =10mA R _L =100Ω	
	Response Time (Fall)	t _f	—	4.5	—	μs		

$$* CTR = \frac{I_C}{I_F} \times 100\%$$

CHARACTERISTICS CURVES

Fig.1 Forward Current vs. Ambient Temperature

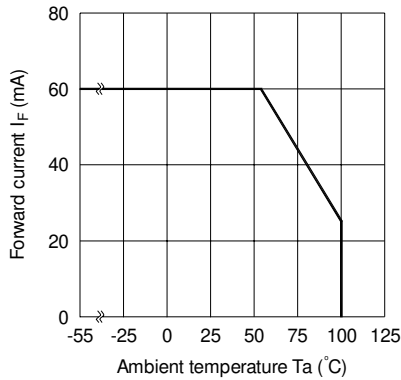

Fig.2 Collector Power Dissipation vs. Ambient Temperature

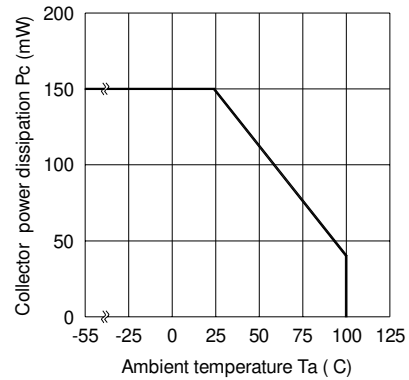

Fig.3 Collector-emitter saturation Voltage vs. Forward current

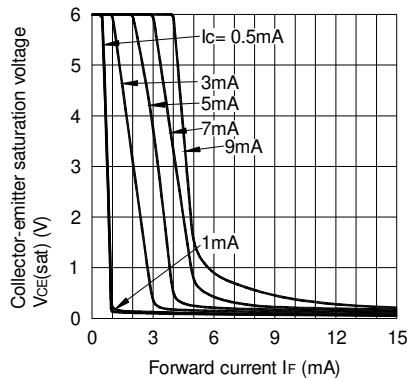

Fig.4 Turn-On Switching Times

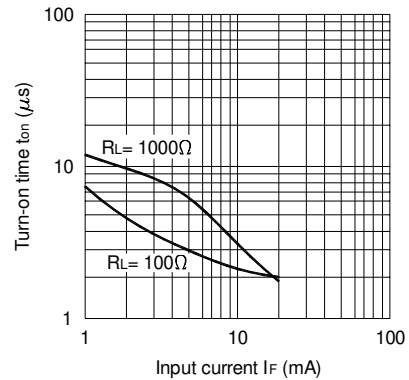

Fig.5 Current Transfer Ratio vs. Forward Current

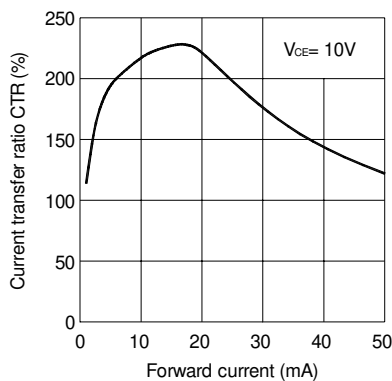
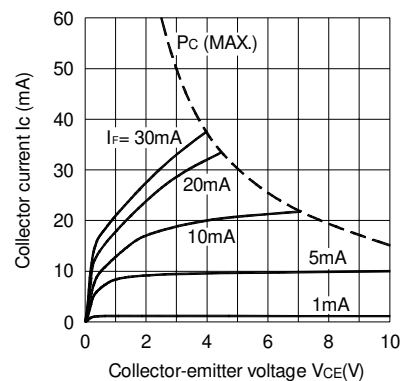

Fig.6 Collector Current vs. Collector-emitter Voltage



CHARACTERISTICS CURVES

Fig.7 Rise and Fall Times

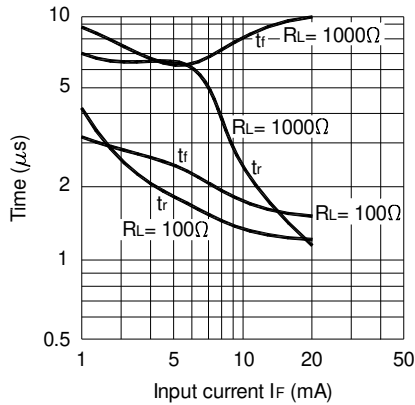
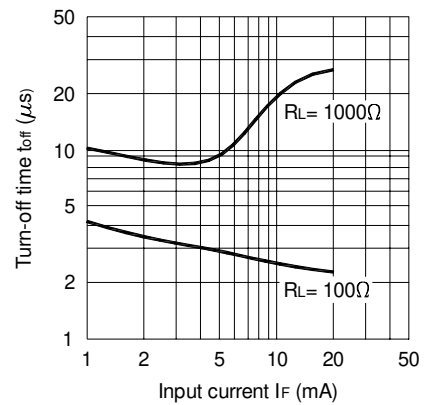
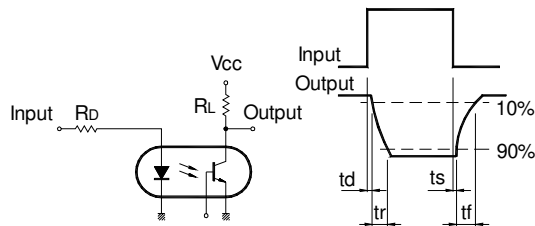

Fig.8 Turn-off Switching Times



Test Circuit for Response Time



Test Circuit for Frequency Response

