

LOC		DIST		REVISIONS			
DF	DO	REV	DATE	DESCRIPTION	DATE	OWN	APVD
		E	05NOV08	REV PER ECO 08-025425		PK	BW

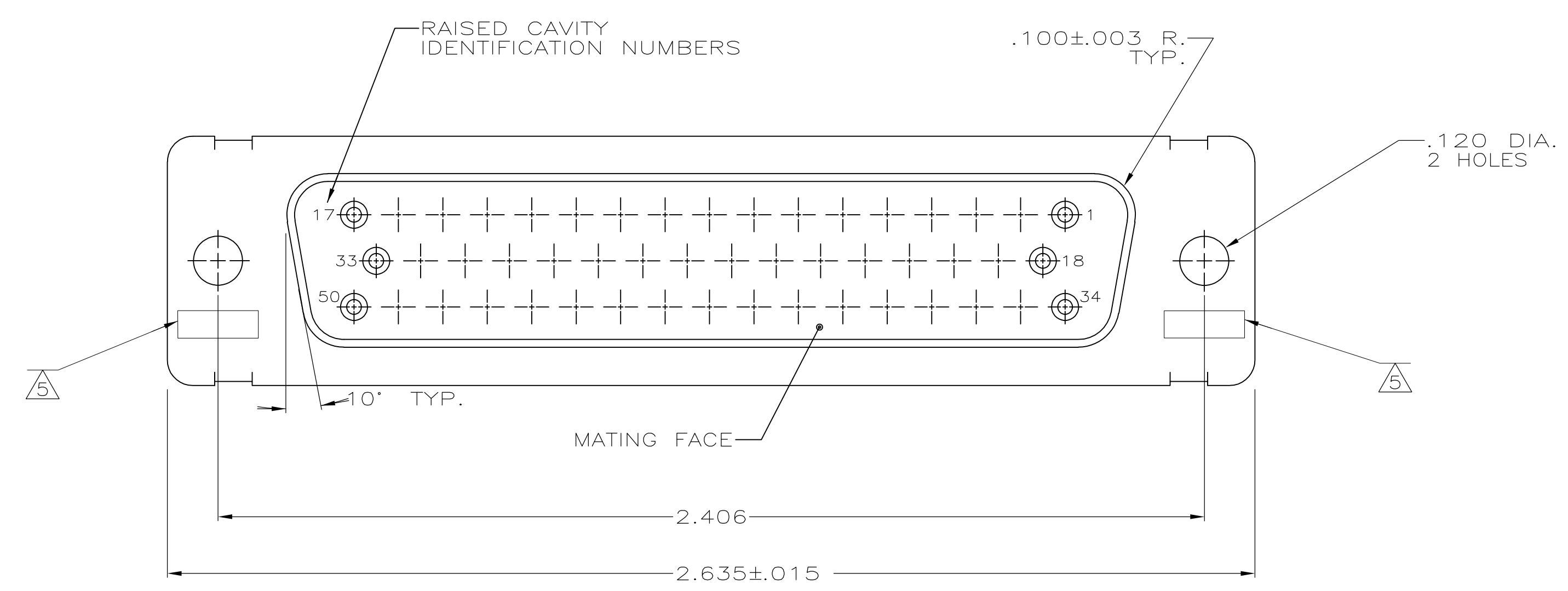

1. THIS RECEPTACLE WILL MATE WITH ANY 50 POSN., SIZE 5 PLUG IN THE AMPLIMITE SERIES.
  2. MAXIMUM WIRE INSULATION USED WITH THIS CONNECTOR IS .068 DIA.
  3. BE-CU RETENTION CLIPS ARE INCLUDED IN INSERT.
  4. CONNECTOR SUPPLIED WITHOUT CONTACTS; SHOWN FOR ILLUSTRATION ONLY.
- ⚠ UL/CSA DESIGNATION STAMPED IN THIS AREA, OPTIONAL

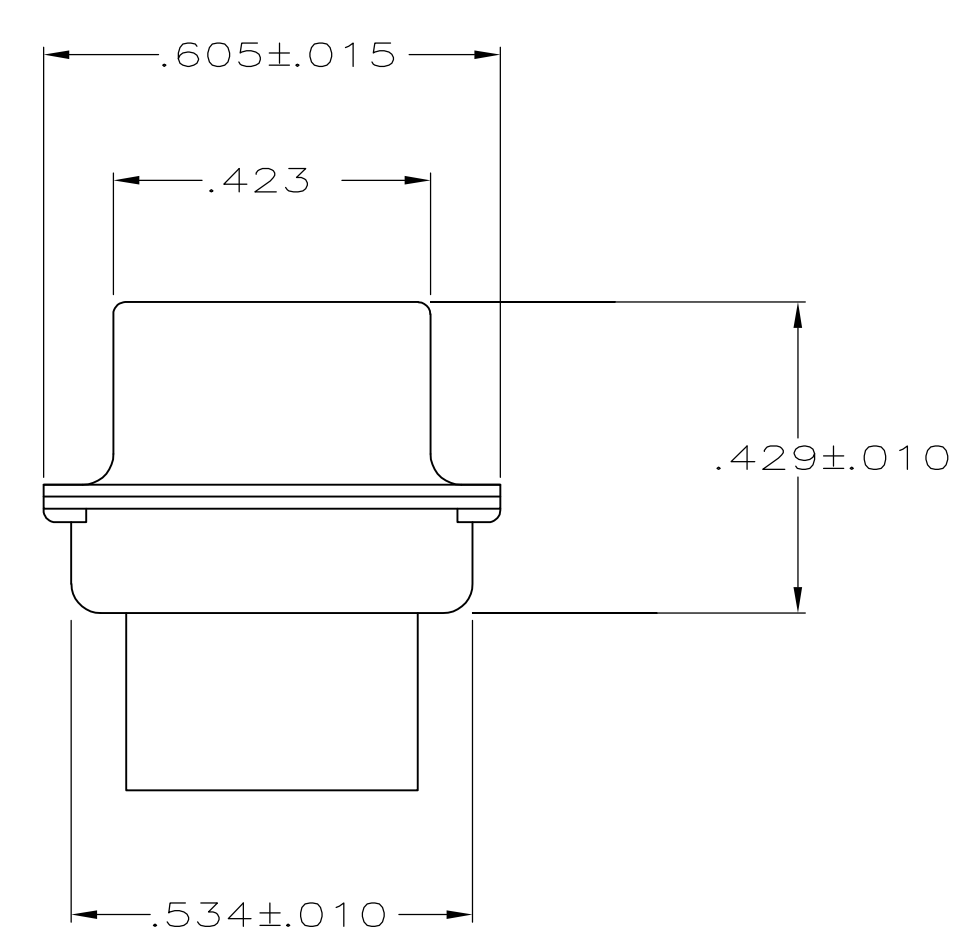
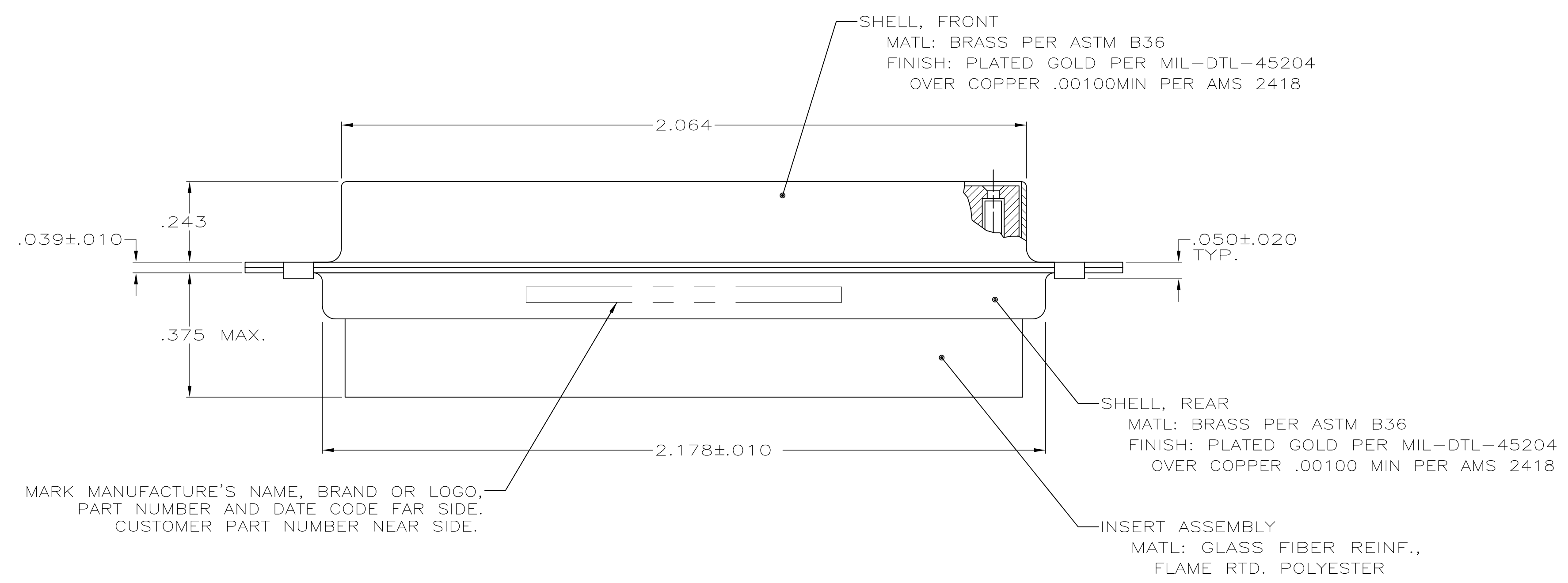

1A01-005RHW	1-211617-1
1A01-005RHA	211617-1
CUSTOMER PART NO	PART NO

THIS DRAWING IS A CONTROLLED DOCUMENT.		DWN T. SHUEY 11-13-87	Tyco Electronics Corporation Harrisburg, PA 17105-3608	
DIMENSIONS: INCHES		CHK F.C. RALLEW III 11-30-87	NAME F.C. RALLEW III	
TOLERANCES UNLESS OTHERWISE SPECIFIED:		APVD F.C. RALLEW III 11-30-87	PRODUCT SPEC	
0 PLC ± -		APPLICATION SPEC		
1 PLC ± -		SIZE		
2 PLC ± -		CAGE CODE		
3 PLC ± .005		DRAWING NO		
4 PLC ± -		RESTRICTED TO		
ANGLES ± 0°30'		A1 00779 ©=211617		
MATERIAL SEE CALLOUTS		WEIGHT		SCALE 4:1
FINISH SEE CALLOUTS		CUSTOMER DRAWING		SHEET 1 OF 1
				REV E