

LOC		DIST		REVISIONS			
P	LTN	DESCRIPTION	DATE	DMN	APVD		
R3		REVISED PER ECR-18-004355	30JUL2018	BDA	SG		
S		REVISED PER ECR-19-015071	16OCT2019	BDA	SW		

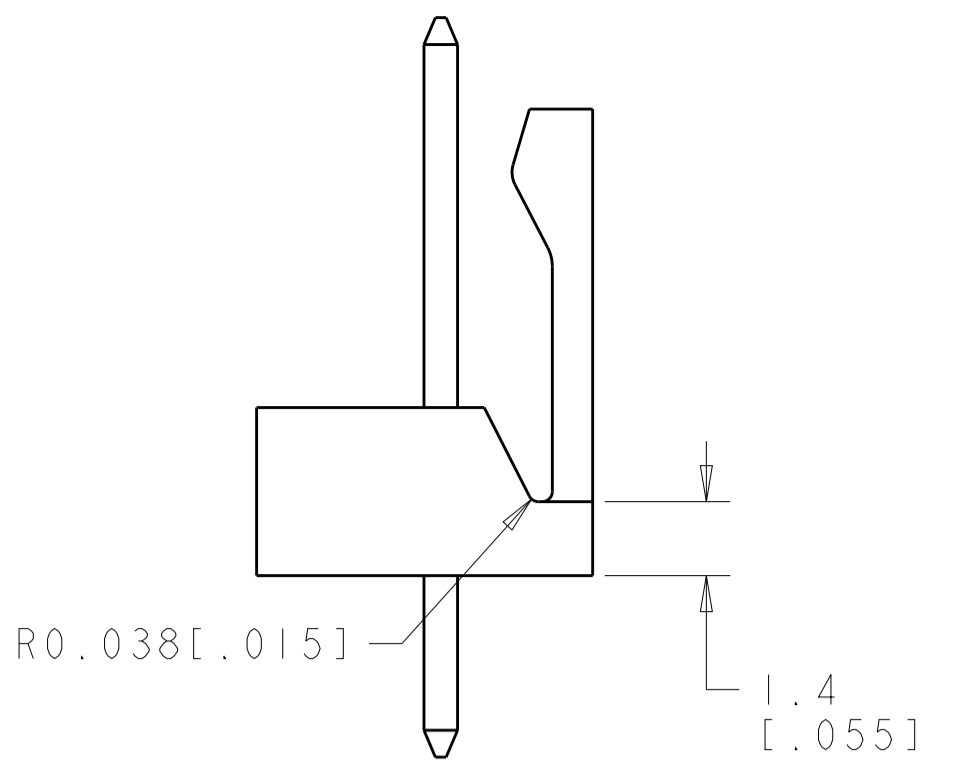

TYPICAL END VIEW FOR 4 THROUGH 7 POSITION

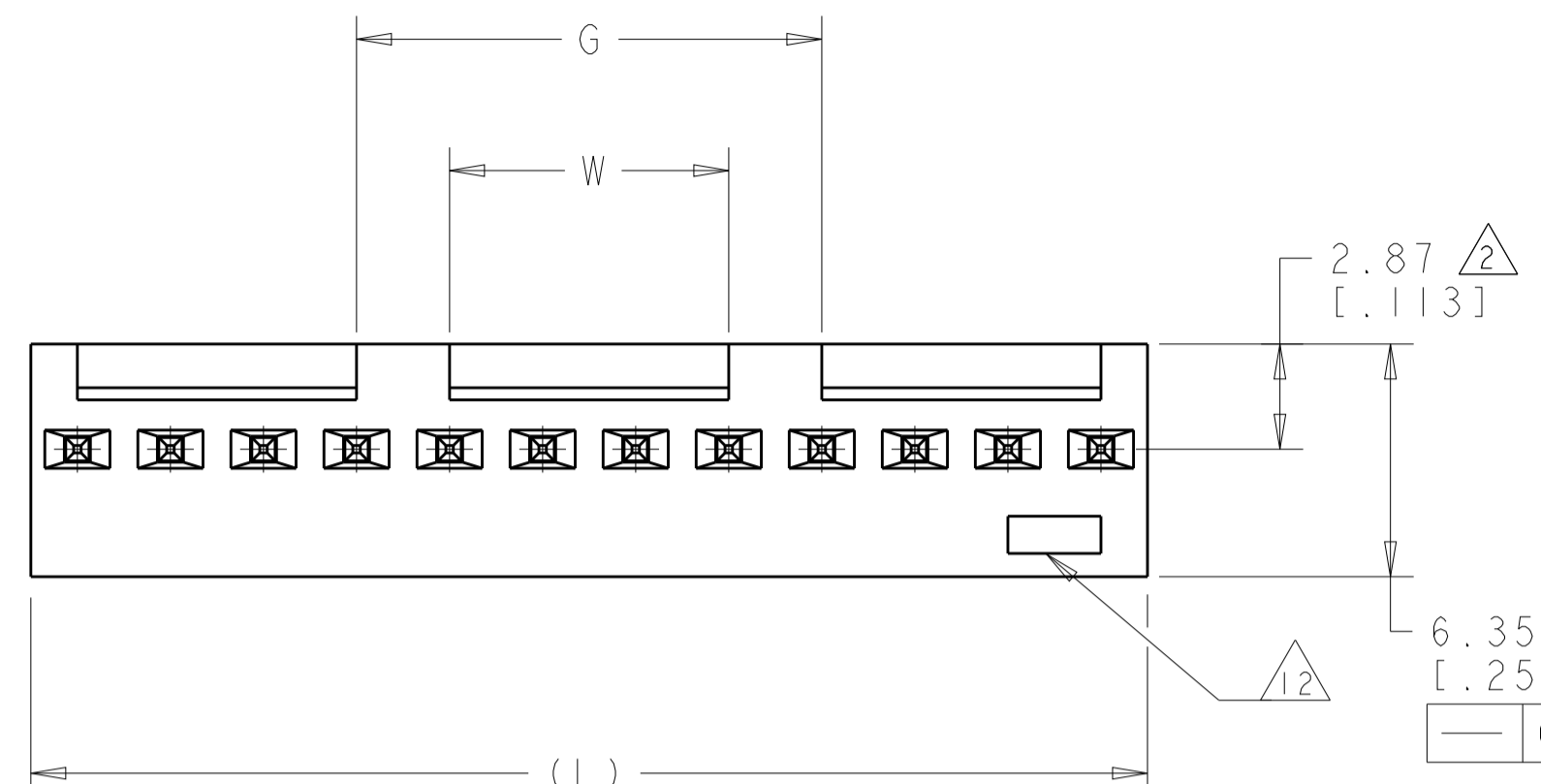
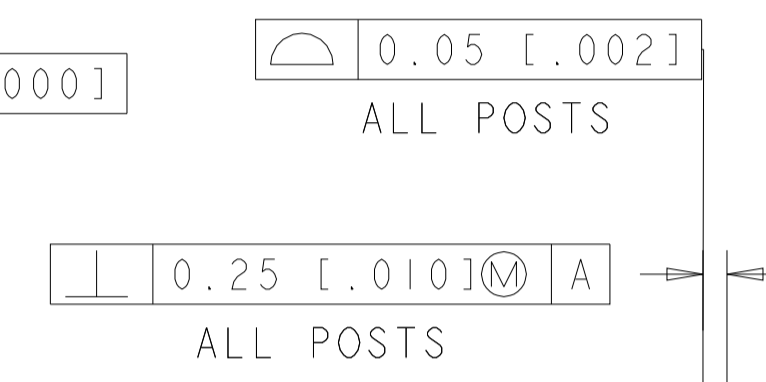

- 1. POST WITHSTAND 13 NEWTONS (3 LBS) MIN AXIAL FORCE IN DIRECTION SHOWN WITHOUT DISLODGING.
- 2. MEASURED AT -A-.
- 3. PARTS COMPLY WITH SOLDERABILITY SPEC 109-11-2.
- 4. MATERIAL:
HOUSING: UL94V-0 NYLON, 4/T, HIGH TEMP, BLACK.
POST - COPPER ALLOY (SEE TABLE FOR PLATING).
- 5. COORDINATE DIMENSION APPLIES FROM CENTER OF ACTUAL FEATURE.
- 6. POSTS TO BE MEASURED WHEN STRIP HELD FLAT.
- 7. DIMENSIONS IN BRACKETS ARE IN INCHES.
- 8. PLATING: GOLD PLATE AREA, 0.00076 [0.00030] GOLD OR 0.00008 [0.00003] MIN GOLD FLASH OVER 0.00068 [0.00027] PALLADIUM NICKEL, PER TE CONNECTIVITY'S DISCRETION, ALL SIDES, OVER NICKEL UNDERPLATE, 0.00127 [0.00050] MIN, ALL SIDES AND ENTIRE LENGTH OF POST.
- 9. BRIGHT TIN/LEAD (93/7) PLATE AREA, 0.00381-0.00889 [0.000150-.000350] THICK, ALL FOUR SIDES, 3.56 [0.140] MIN.
- 10. TOLERANCES APPLY TO SOLDER SIDE OF BOARD.
- 11. ONE HOLE MAY BE UNDERSIZED 0.81-0.90 [0.032-.035] DIAMETER FOR ASSEMBLY RETENTION DURING PROCESSING.
- 12. TE LOGO, UL, AND CSA TRADEMARKS TO APPEAR ON THIS SURFACE.
- 13. MATTE TIN PLATE AREA, 0.00381-0.00889 [0.000150-.000350] THICK, ALL FOUR SIDES, 3.56 [0.140] MIN.
- 14. OBSOLETE PARTS: OBSOLETE CIS STREAMLINING PER D.RENAUD/D.SINISI

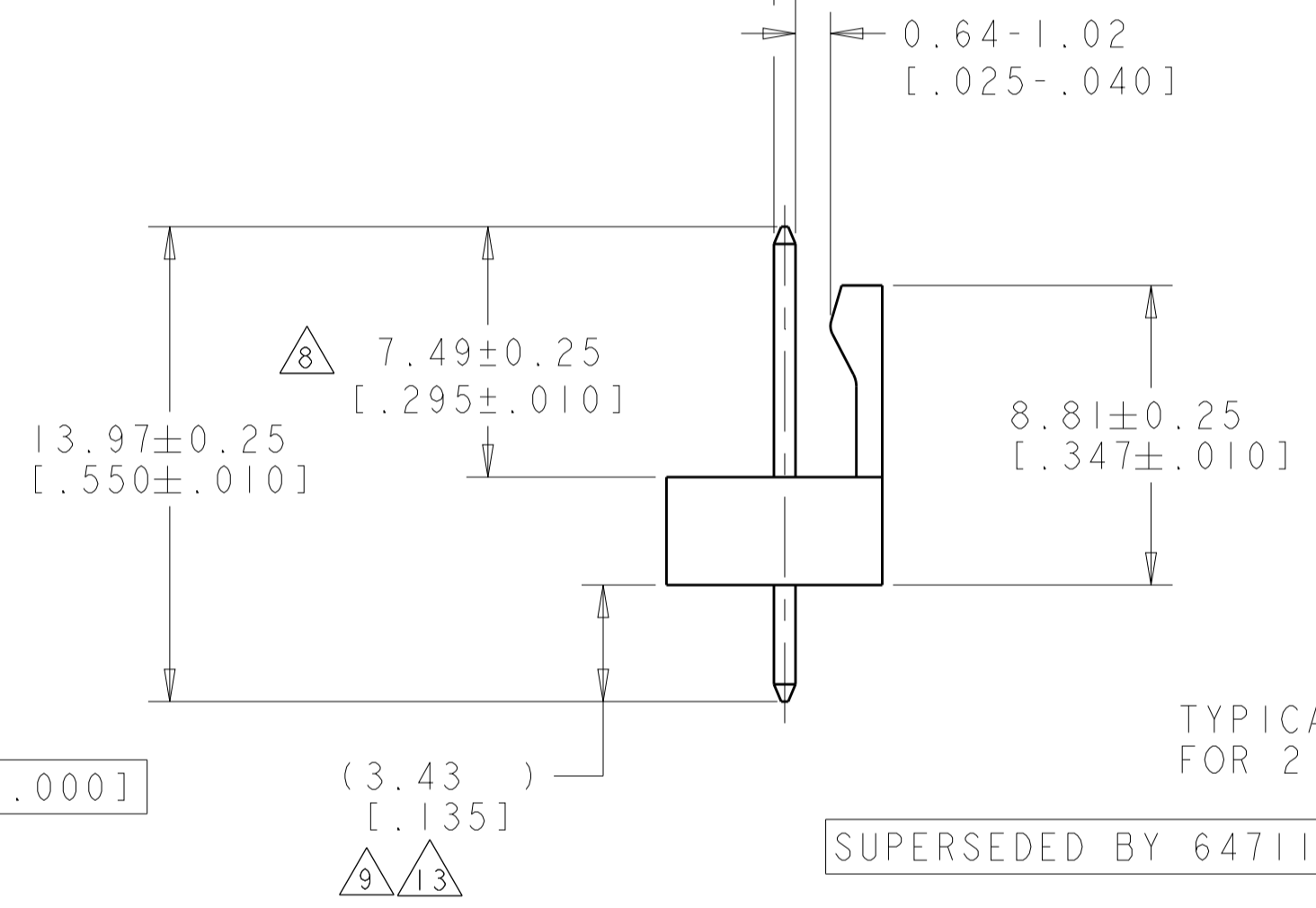
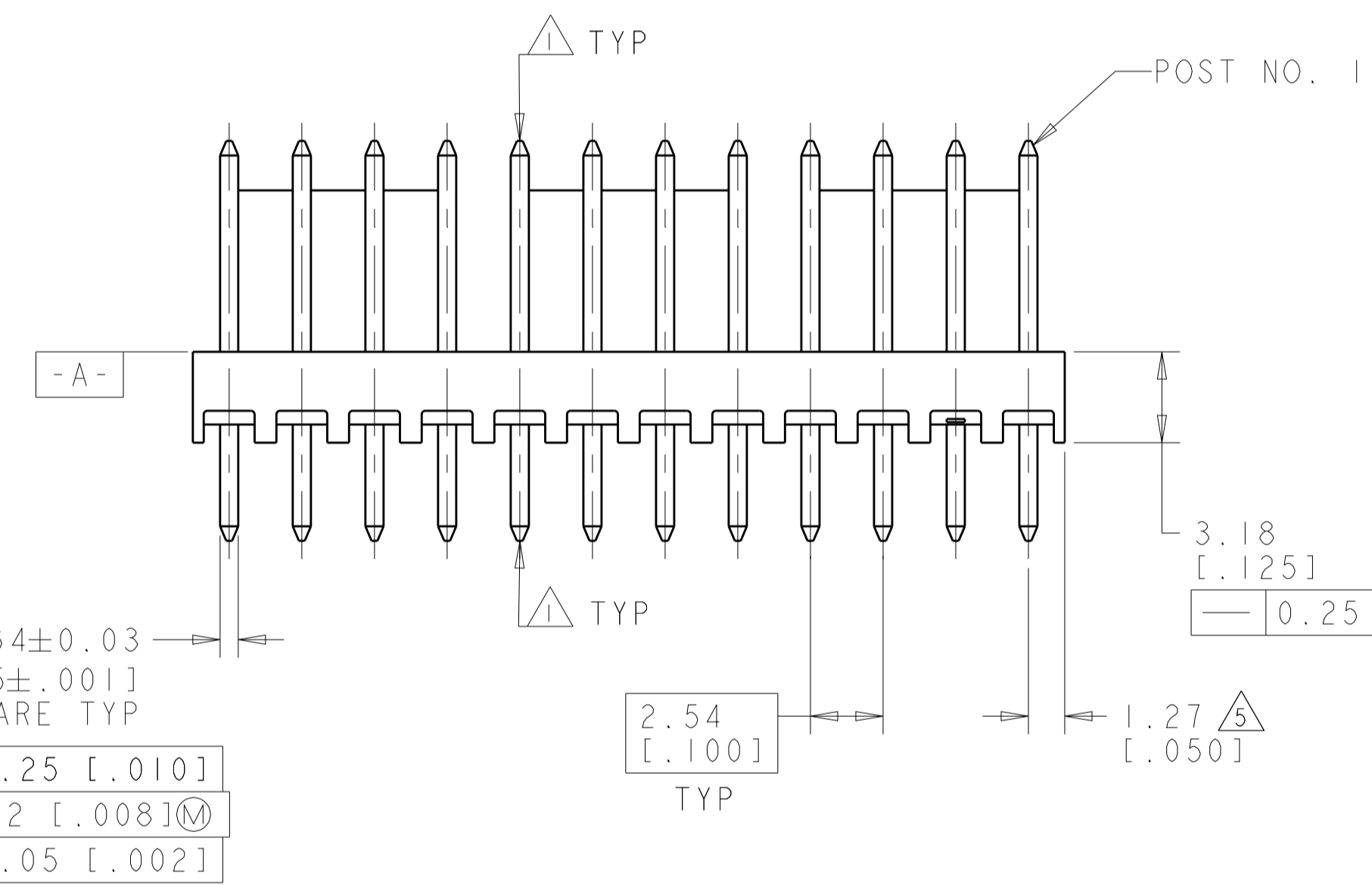

TYPICAL END VIEW FOR 2 POSITION ONLY

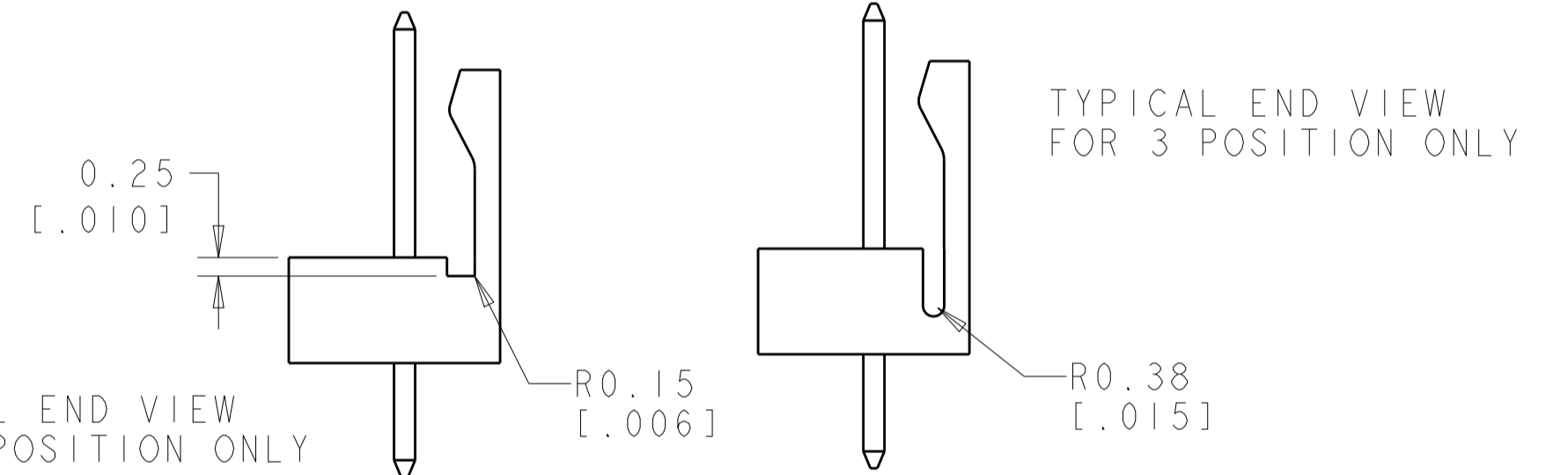

TYPICAL END VIEW FOR 3 POSITION ONLY

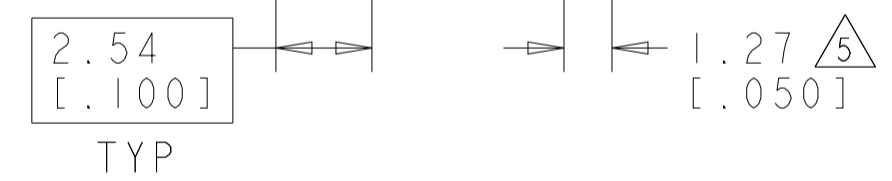
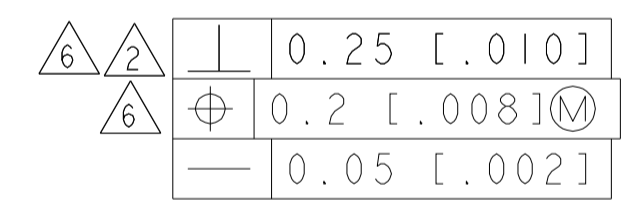

SUPERSEDED BY 647116-MXCU

POST FINISH	W	G	L	NO OF POSN	PART NO	
8, 9	12.70 [0.500]	25.40 [1.000]	43.18 [1.700]	17	4-647116-7	
	7.62 [0.300]	12.70 [0.500]	30.48 [1.200]	12	4-647116-2	
	-	10.16 [0.400]	27.94 [1.100]	11	4-647116-1	
	-	7.62 [0.300]	25.40 [1.000]	10	4-647116-0	
	-	5.08 [0.200]	22.86 [0.900]	9	3-647116-9	
	-	2.54 [0.100]	20.32 [0.800]	8	3-647116-8	
	-	-	17.78 [0.700]	7	3-647116-7	
	-	-	15.24 [0.600]	6	3-647116-6	
	-	-	12.70 [0.500]	5	3-647116-5	
	-	-	10.16 [0.400]	4	3-647116-4	
	-	-	7.62 [0.300]	3	3-647116-3	
	-	-	5.08 [0.200]	2	3-647116-2	
	8, 9	7.62 [0.300]	12.70 [0.500]	30.48 [1.200]	12	1-647116-2
		-	10.16 [0.400]	27.94 [1.100]	11	1-647116-1
		-	7.62 [0.300]	25.40 [1.000]	10	1-647116-0
		-	5.08 [0.200]	22.86 [0.900]	9	647116-9
		-	2.54 [0.100]	20.32 [0.800]	8	647116-8
-		-	17.78 [0.700]	7	647116-7	
-		-	15.24 [0.600]	6	647116-6	
8, 9	-	-	12.70 [0.500]	5	647116-5	
	-	-	10.16 [0.400]	4	647116-4	
	-	-	7.62 [0.300]	3	647116-3	
	-	-	5.08 [0.200]	2	647116-2	
	-	-	-	-	-	

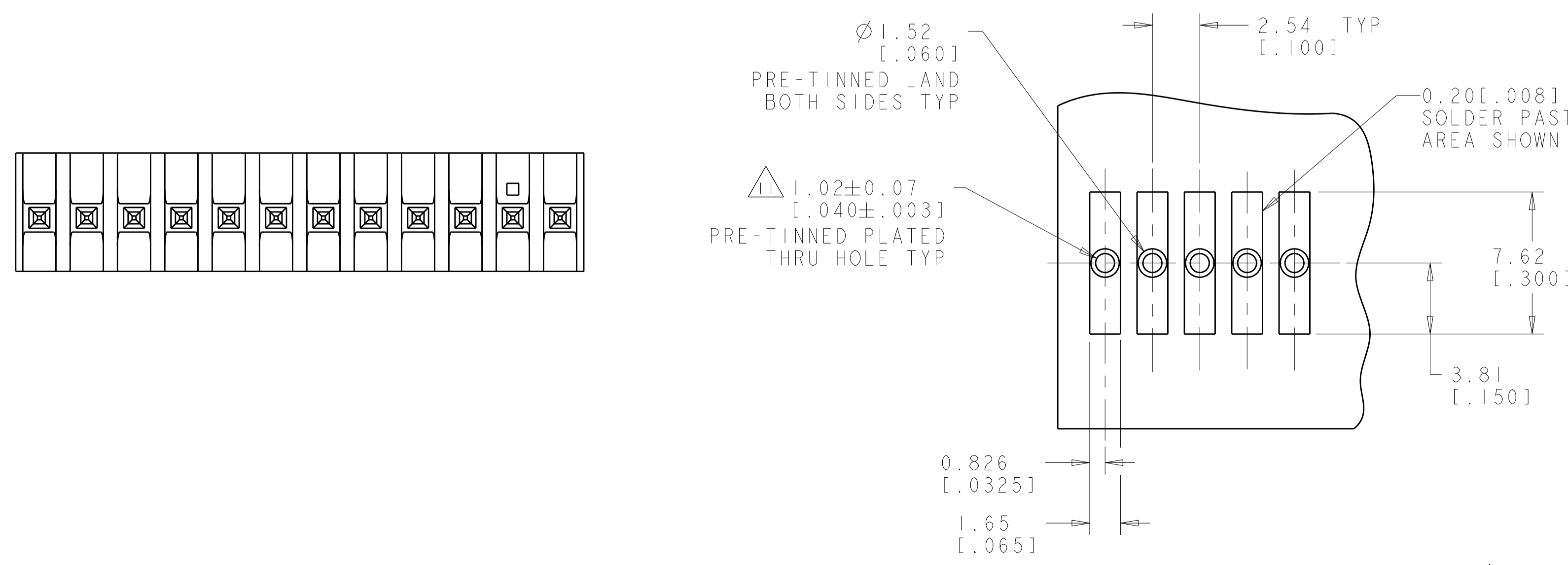

RECOMMENDED MOUNTING HOLE PATTERN FOR 1.57±0.20 [0.062±0.008] THICK P.C. BOARD

- 1. SUP 4-647116-1
- 2. SUP 4-647116-0
- 3. OBSOLETE
- 4. SUP 3-647116-8
- 5. SUP 3-647116-7
- 6. SUP 3-647116-5
- 7. SUP 3-647116-3

THIS DRAWING IS A CONTROLLED DOCUMENT. CHK. D. BOSSI, APVD. D. BOSSI, DATE: 01NOV2001. DWG. H. WHITAKER, DATE: 01NOV2001.

STE TE Connectivity

NAME: MTA-100 HEADER ASSY, HIGH TEMPERATURE FRICTION LOCK, .025 SQUARE, STRAIGHT POST, .000030 GOLD

SIZE: A1, CAGE CODE: 00779, DRAWING NO: 647116, SHEET 1 OF 1, REV S