

MATERIALS AND FINISHES:

TAPE: SHEET 2
REEL: SHEET 3

BODY: BRASS
PLATED: GOLD (10μ-in MIN)
OVER NICKEL (100μ-in MIN)

CONTACT: BERYLLIUM COPPER
PLATED: GOLD (30μ-in MIN)
OVER NICKEL (100μ-in MIN)

INSULATOR: PEEK OR LCP

KAPTON: POLYIMIDE
COLOR: BLACK

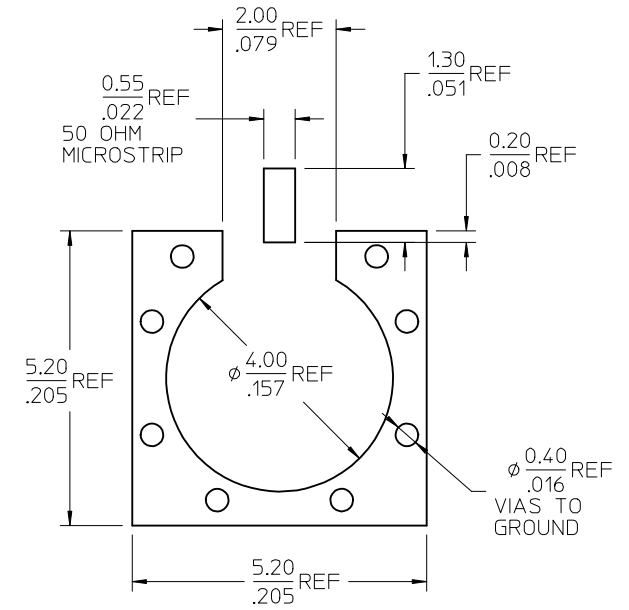
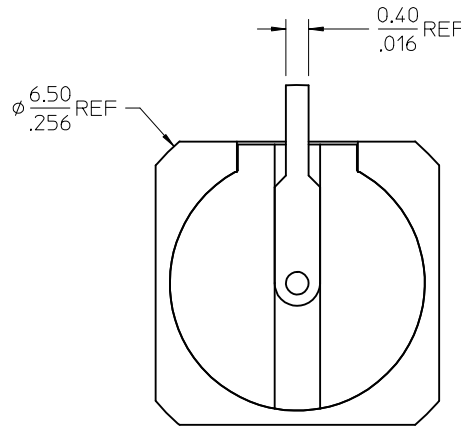
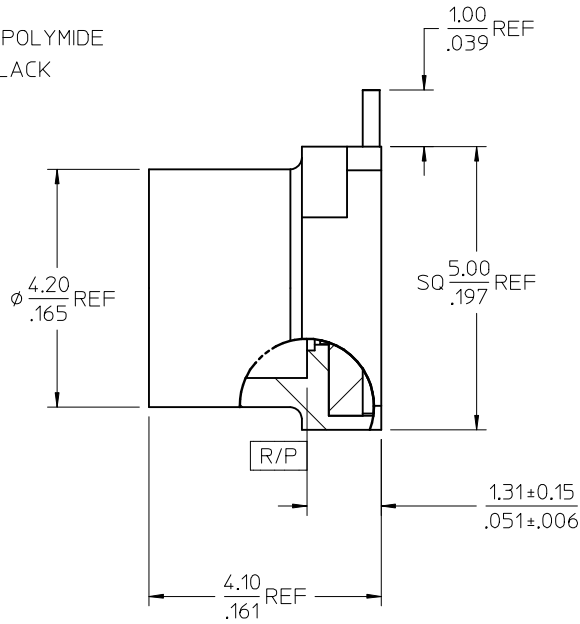
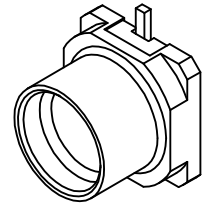

RECOMMENDED PCB LAYOUT

73415-3811	73415-3810, ONE PER BAG
73415-3810	TAPE AND REEL WITH KAPTON
PART NO.	PACKAGING

PS-89675-3320	PRODUCT SPECIFICATION
MIL-STD-348B, FIG. 326.4	INTERFACE SMP SB
SPECIFICATION	DESCRIPTION

CHG: ADD TOLERANCE TO DIM 1.31/.051 IN E9_ZONE
UPD MATERIALS AND FINISHES NOTE.
EC NO: URF2017-0403
DRWIN:APRAKASH01 2017/05/31
CHKD:888 2017/05/31
APPR:AROBERTSON 2017/06/29

QUALITY SYMBOLS	DESCRIPTION
▽=0	
▽=0	
▽=0	

GENERAL TOLERANCES (UNLESS SPECIFIED)	
	mm INCH
4 PLACES	± --- ± ---
3 PLACES	± --- ± .010
2 PLACES	± 0.25 ± ---
1 PLACE	± --- ± ---
0 PLACE	± --- ± ---
ANGULAR ± 2 °	
DRAFT WHERE APPLICABLE MUST REMAIN WITHIN DIMENSIONS	

DIMENSION STYLE MM/IN	
DRAWN BY	DATE
TEF	2002/03/25
CHECKED BY	DATE
SSS	2002/03/25
APPROVED BY	DATE
GMH	2002/03/25
MATERIAL NO.	DOCUMENT NO.
SEE TABLE	SD-73415-381

SCALE	DESIGN UNITS METRIC	THIRD ANGLE PROJECTION
TITLE		
SMP PLUG SMOOTH BORE PCB SMT 50 OHM SMP-P/PCB, EWR-3604		
molex		
DOCUMENT NO.		SHEET NO.
SD-73415-381		1 OF 3
THIS DRAWING CONTAINS INFORMATION THAT IS PROPRIETARY TO MOLEX INCORPORATED AND SHOULD NOT BE USED WITHOUT WRITTEN PERMISSION		

NOTE:
 1. 10 PITCHES CUMULATIVE TOLERANCE ±0.20(.008)

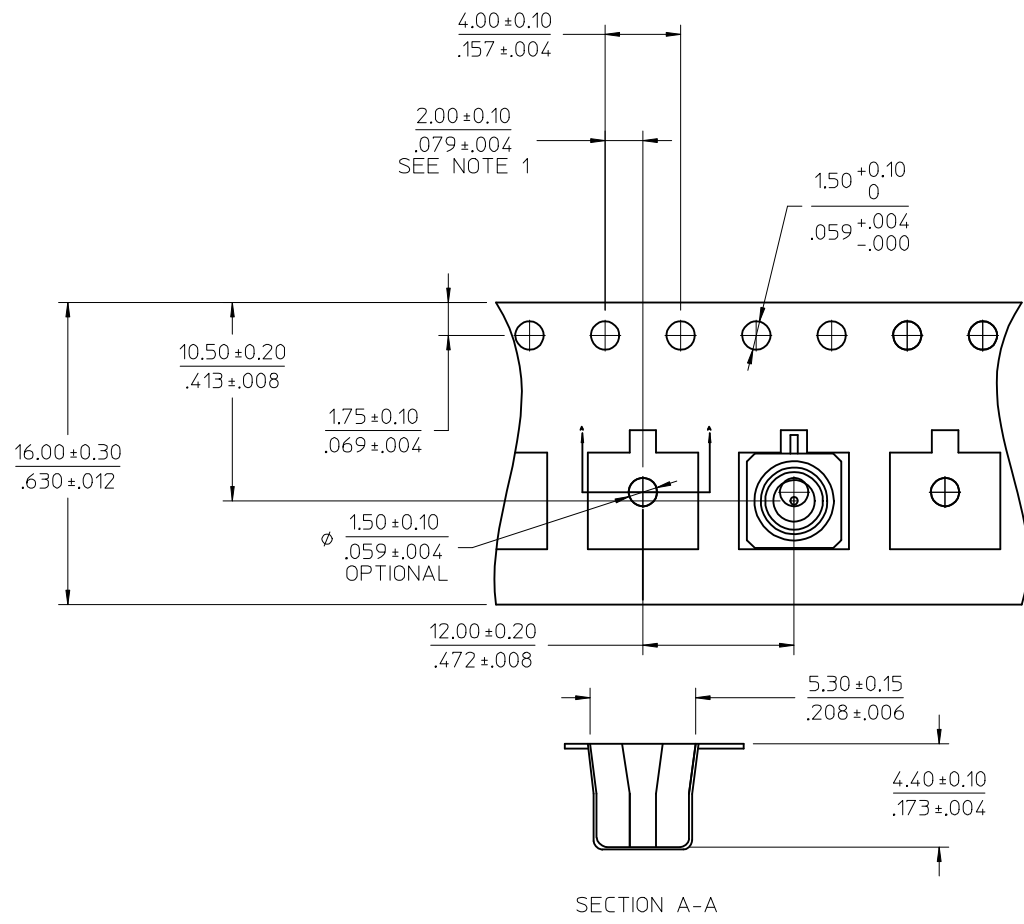

CHG: SEE SHEET 1
 EC NO: URF2017-0403
 DRW:APRAKASHO1 2017/05/31
 CHKD:BBB 2017/05/31
 APPR:AROBERTSON 2017/06/29

REV	DESCRIPTION
A4	

QUALITY SYMBOLS	
	0
	0
	0

GENERAL TOLERANCES (UNLESS SPECIFIED)	
	mm
	INCH
4 PLACES	± .25
3 PLACES	± .10
2 PLACES	± .05
1 PLACE	± .02
0 PLACE	± .01

DIMENSION STYLE		SCALE	DESIGN UNITS	THIRD ANGLE PROJECTION
MM/IN			METRIC	
DRAWN BY	DATE	TITLE		
TEF	2002/03/25	SMP PLUG SMOOTH BORE		
CHECKED BY	DATE	PCB SMT 50 OHM		
SSS	2002/03/25	SMP-P/PCB, EWR-3604		
APPROVED BY	DATE	molex		
GMH	2002/03/25			
MATERIAL NO.		DOCUMENT NO.		SHEET NO.
SEE SHEET 1		SD-73415-381		2 OF 3
DRAFT WHERE APPLICABLE MUST REMAIN WITHIN DIMENSIONS				
THIS DRAWING CONTAINS INFORMATION THAT IS PROPRIETARY TO MOLEX INCORPORATED AND SHOULD NOT BE USED WITHOUT WRITTEN PERMISSION				

LABEL:
 - ORDER NO.
 - QUANTITY
 - PART NUMBER
 - LOT NO.

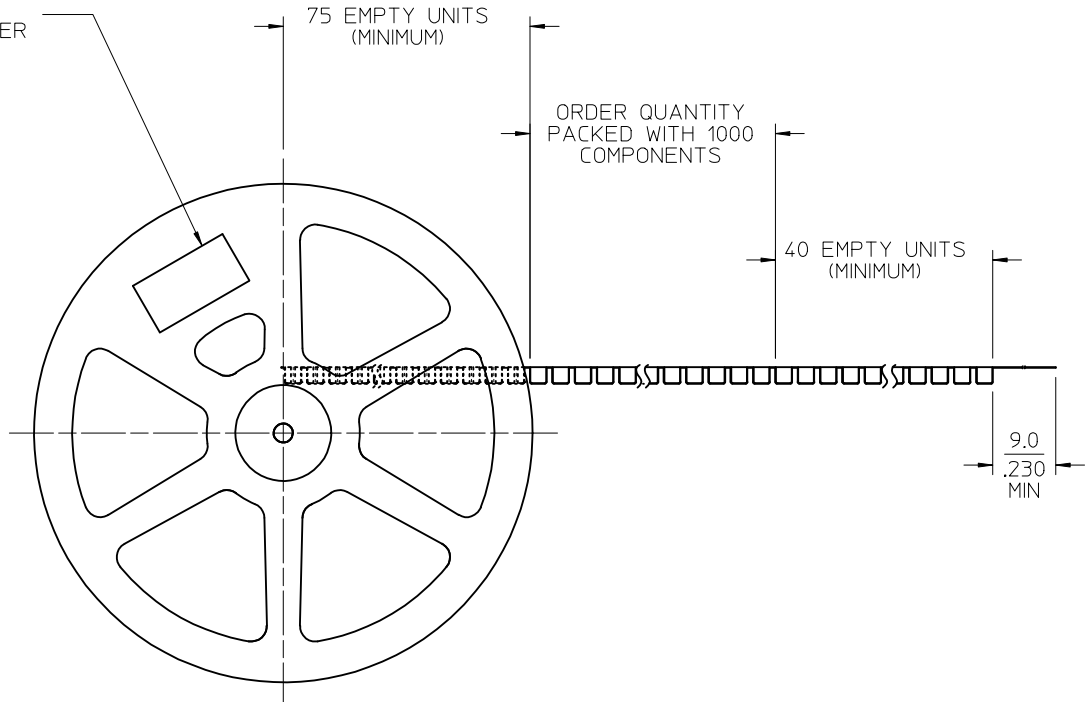
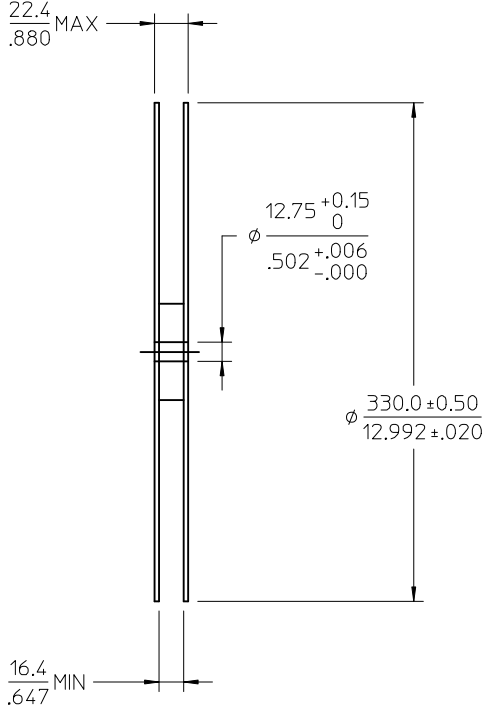

CHG: SEE SHEET 1 IEC NO: URF2017-0403 DRWN:APRAKASHO1 2017/05/31 CHKD:888 2017/05/31 APPR:AROBERTSON 2017/06/29	QUALITY SYMBOLS	GENERAL TOLERANCES (UNLESS SPECIFIED)	DIMENSION STYLE	SCALE	DESIGN UNITS	THIRD ANGLE PROJECTION
	▽=0	mm INCH	MM/IN		METRIC	
	▽=0	4 PLACES ± --- ± ---	DRAWN BY DATE	TITLE		
	▽=0	3 PLACES ± --- ± .010	CHECKED BY DATE	SMP PLUG SMOOTH BORE		
		2 PLACES ± 0.25 ± ---	SSS 2002/03/25			PCB SMT 50 OHM
		1 PLACE ± --- ± ---	APPROVED BY DATE			SMP-P/PCB, EWR-3604
		0 PLACE ± --- ± ---	GMH 2002/03/25			molex
		ANGULAR ± 2 °	MATERIAL NO.	DOCUMENT NO.		SD-73415-381
		DRAFT WHERE APPLICABLE MUST REMAIN WITHIN DIMENSIONS	SEE SHEET 1			SHEET NO. 3 OF 3
A4			SIZE C	THIS DRAWING CONTAINS INFORMATION THAT IS PROPRIETARY TO MOLEX INCORPORATED AND SHOULD NOT BE USED WITHOUT WRITTEN PERMISSION		