

DO NOT SCALE  
DIMENSIONS IN mm

METRIC

THIRD ANGLE  
PROJECTION

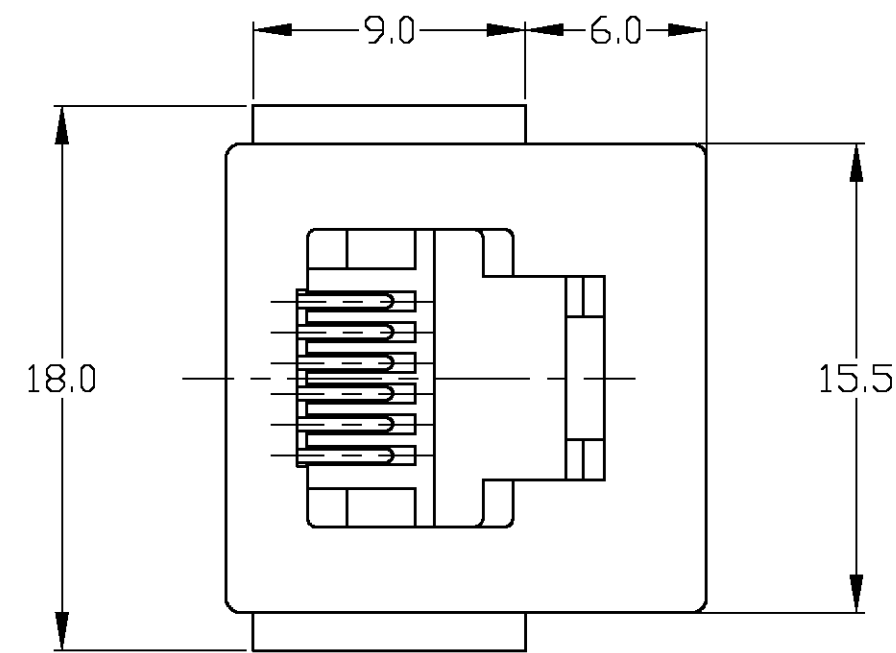

NOTES:

- 1 TOLERANCES UNLESS OTHERWISE SPECIFIED:  $\pm 0,15$
- 2 FOR APPLICATION INFORMATION SEE AMP SPEC. 114-19019
- 3 FOR PERFORMANCE REQUIREMENTS SEE AMP SPEC. 108-19064
- 4 PACKAGING: BULK PACKAGED.  
TRUE POSITIONING OF THE SOLDER TINES  
MAY BE AFFECTED BY BULK PACKAGING.

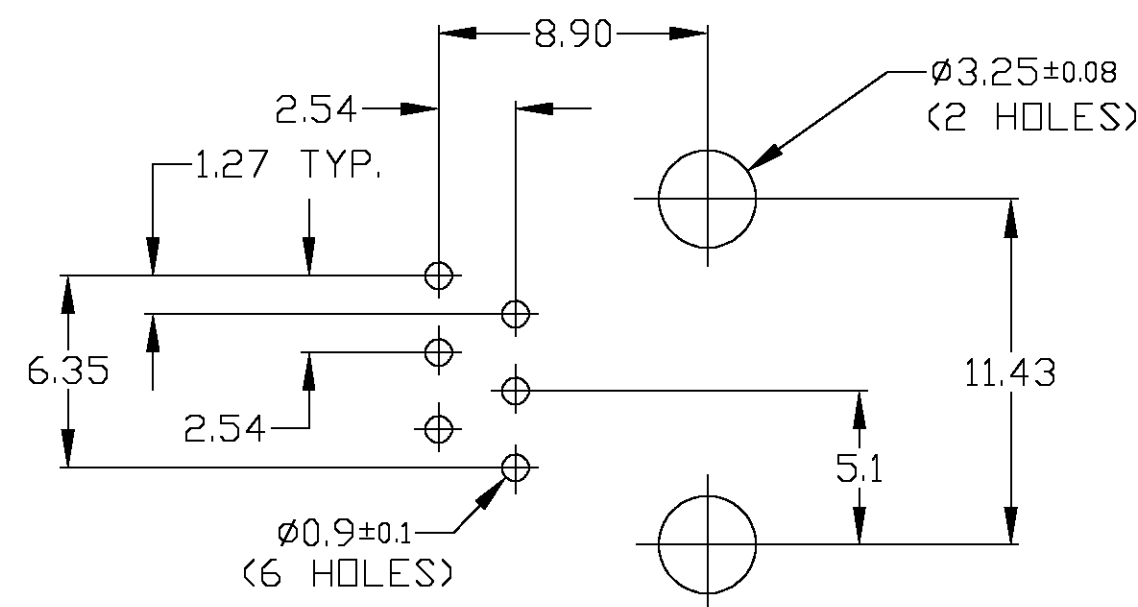
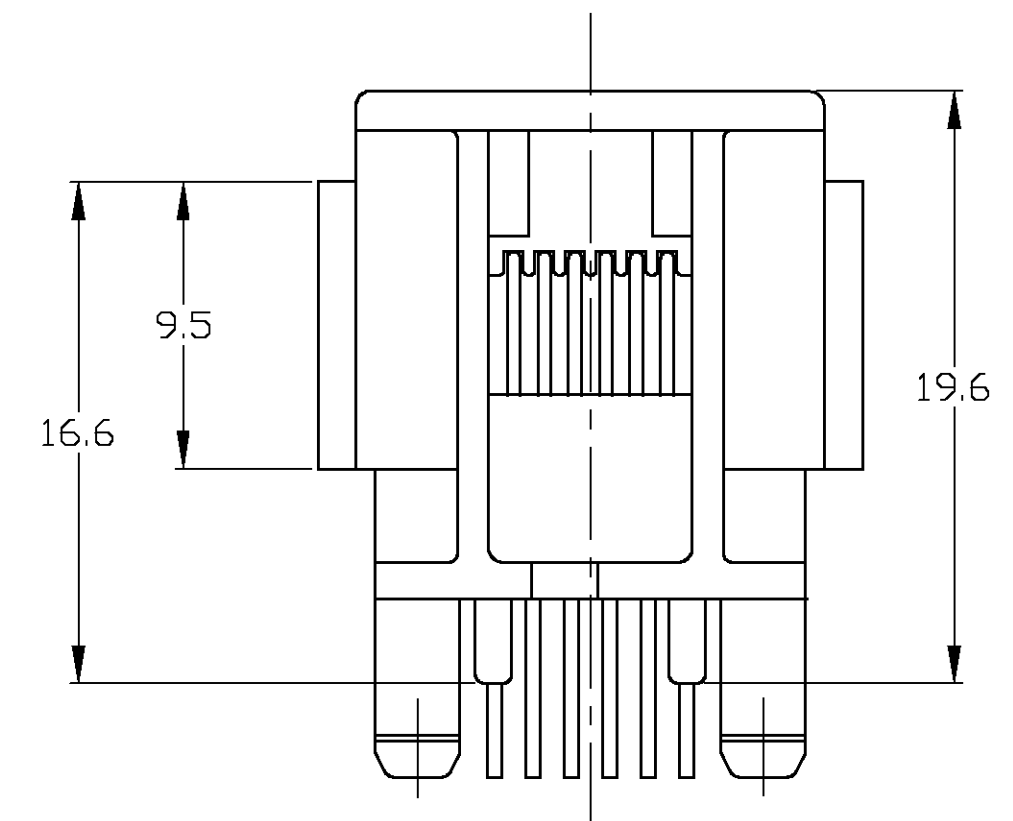
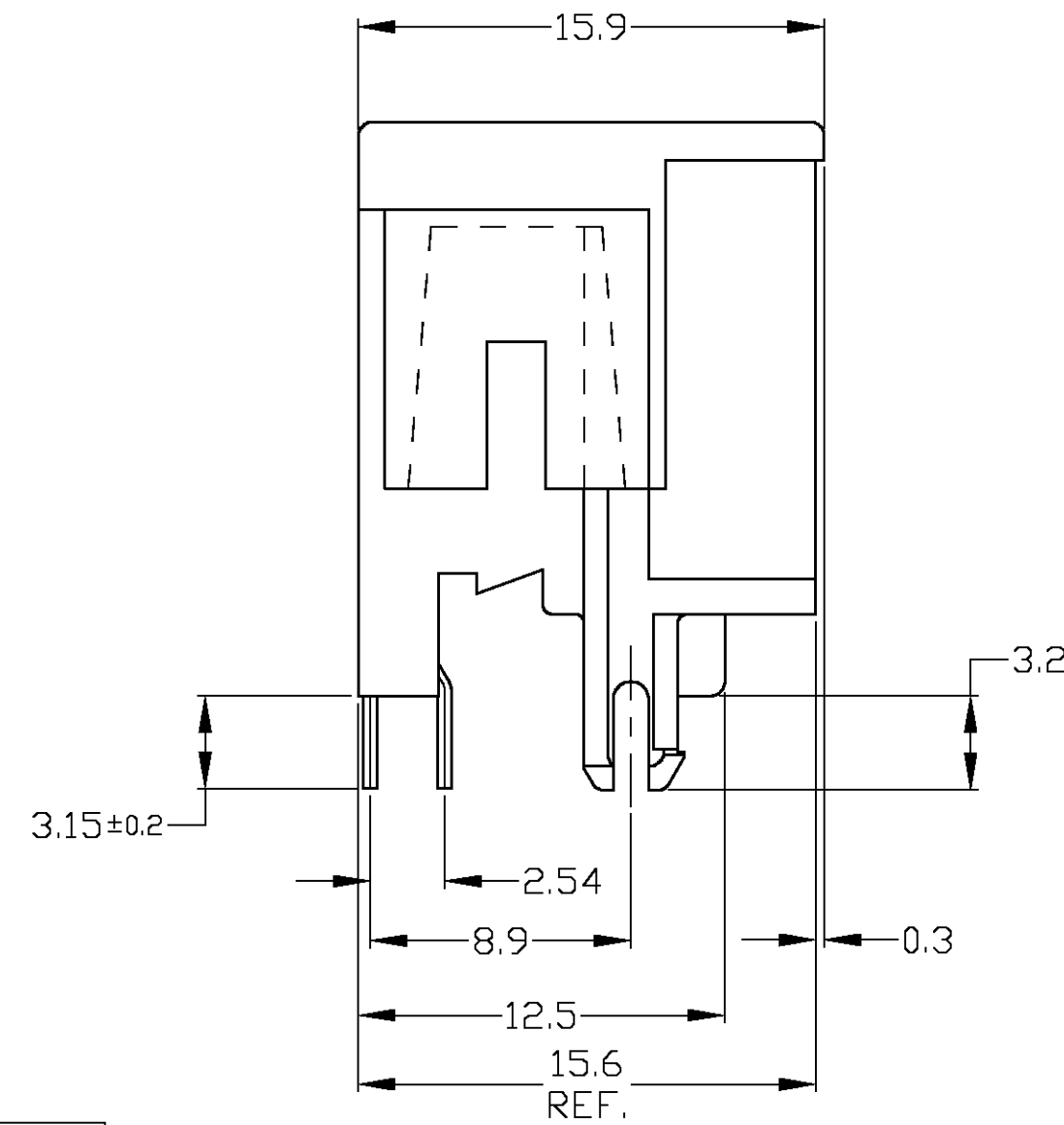
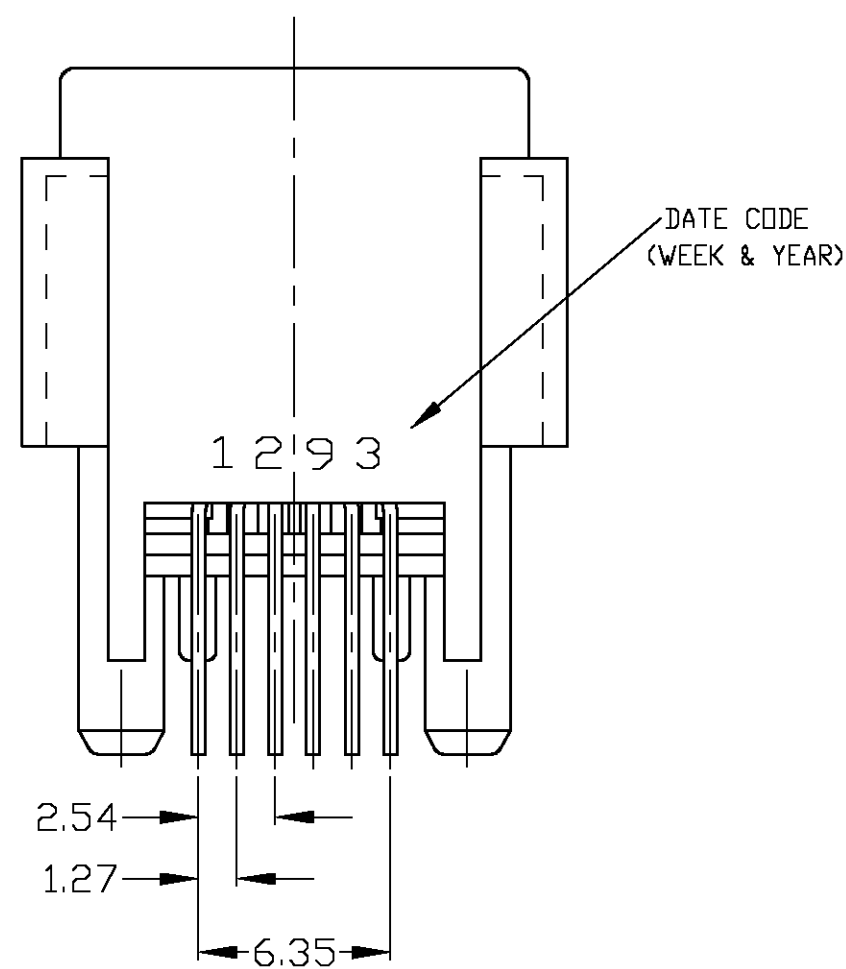

PRINTED CIRCUIT BOARD LAYOUT

[VIEW SHOWN IS CIRCUIT (NONCOMPONENT) SIDE OF BOARD.]

PRINTED CIRCUIT BOARD THICKNESS: 1,6 mm NOMINAL.

TOLERANCES UNLESS OTHERWISE SPECIFIED  $\pm 0,05$ .

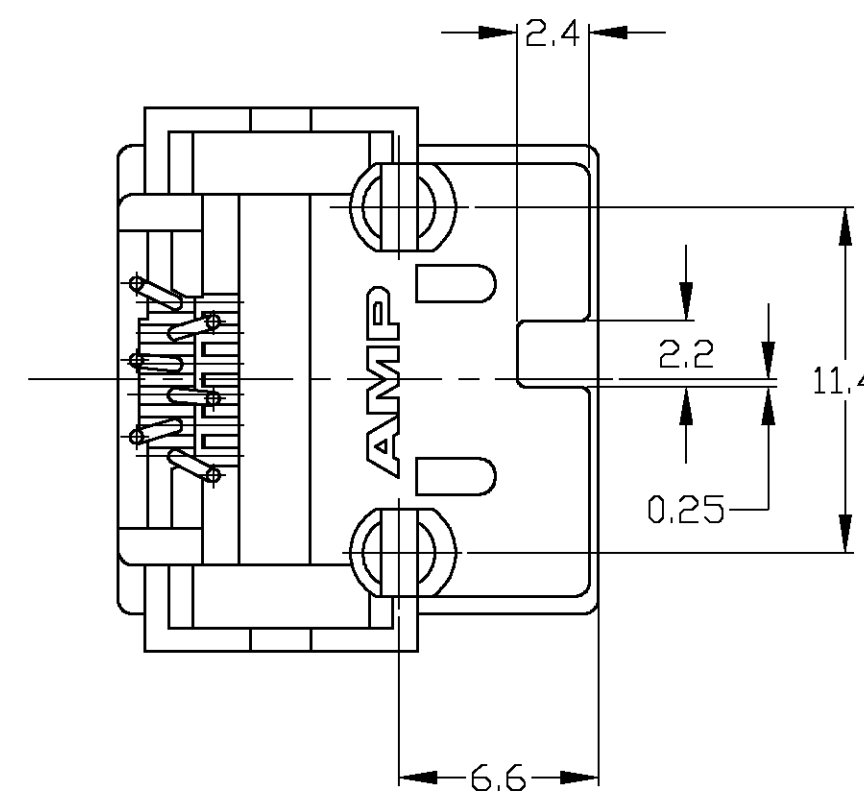

6 POSITIONS / 6 CONTACTS	IN CONTACT AREA 1,2µm MIN SEL HARD GOLD OVER 1,2µm MIN NICKEL	HOUSING PBT, UL 94V-0 COLOR: BLACK	100190-2
REMARKS	FINISH	MATERIAL	P/N
F SR10-0084-02	KV 06 FEB 02	CUSTOMER DRAWING FOR REFERENCE ONLY WILL NOT BE UPDATED	
E EH-1142-97	EvE W.B. 19 NOV 97	© COPYRIGHT 19 BY AMP HOLLAND B.V. ALL INTERNATIONAL RIGHTS RESERVED. AMP PRODUCTS MAY BE COVERED BY U.S. AND FOREIGN AND/OR PATENTS PENDING.	
D EH-0217-93	R.D. 04-11-93	THIS DRAWING IS UNPUBLISHED RELEASED FOR PUBLICATION	
C H-9194	D.K. 09-03-92	Tyco Electronics Corporation Oostkamp - BELGIUM	
B H-9194	JvdH 16-10-91		
A H-9194	JvdH 09-10-91	NAME MODULAR JACK, 6 POS., TOP ENTRY	
LTR. REVISION RECORD	DR. CHK. DATE	HIGH PROFILE, WITH PANEL STOPS	
		FOR PRINTED CIRCUIT BOARD	
DR.: J.V.D.HEIJDEN DATE: 08-10-91	CHK.: C.STERKEN DATE:	APP.: L.V.SOEST DATE:	DWG.No. C-100190
		REV.LTR. F	SHEET 1 OF 1
		A2	