

TB6631FNG

3-Phase Full-Wave Sine-Wave PWM Brushless Motor Controller

The TB6631FNG is designed for motor fan applications for three-phase brushless DC motors.

Features

- Sine-wave PWM control
- Triangular-wave generator
(with a carrier frequency of $f_{osc}/252$ Hz)
- Lead angle control (0° to 58° in 32 separate steps)
Automatic internal control by FG frequency
- Current-limiting input pin
- Voltage regulator ($V_{refout} = 5$ V (typ.), 30 mA (max))
- Operating supply voltage range: $V_{CC} = 7$ V to 16.5 V

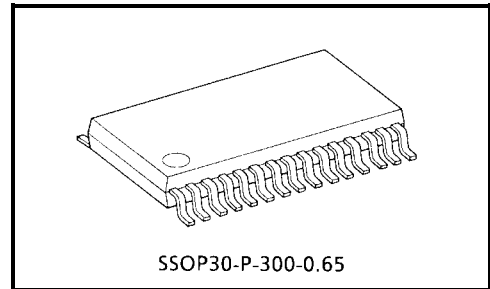

Weight: 0.17 g (typ.)

Block Diagram

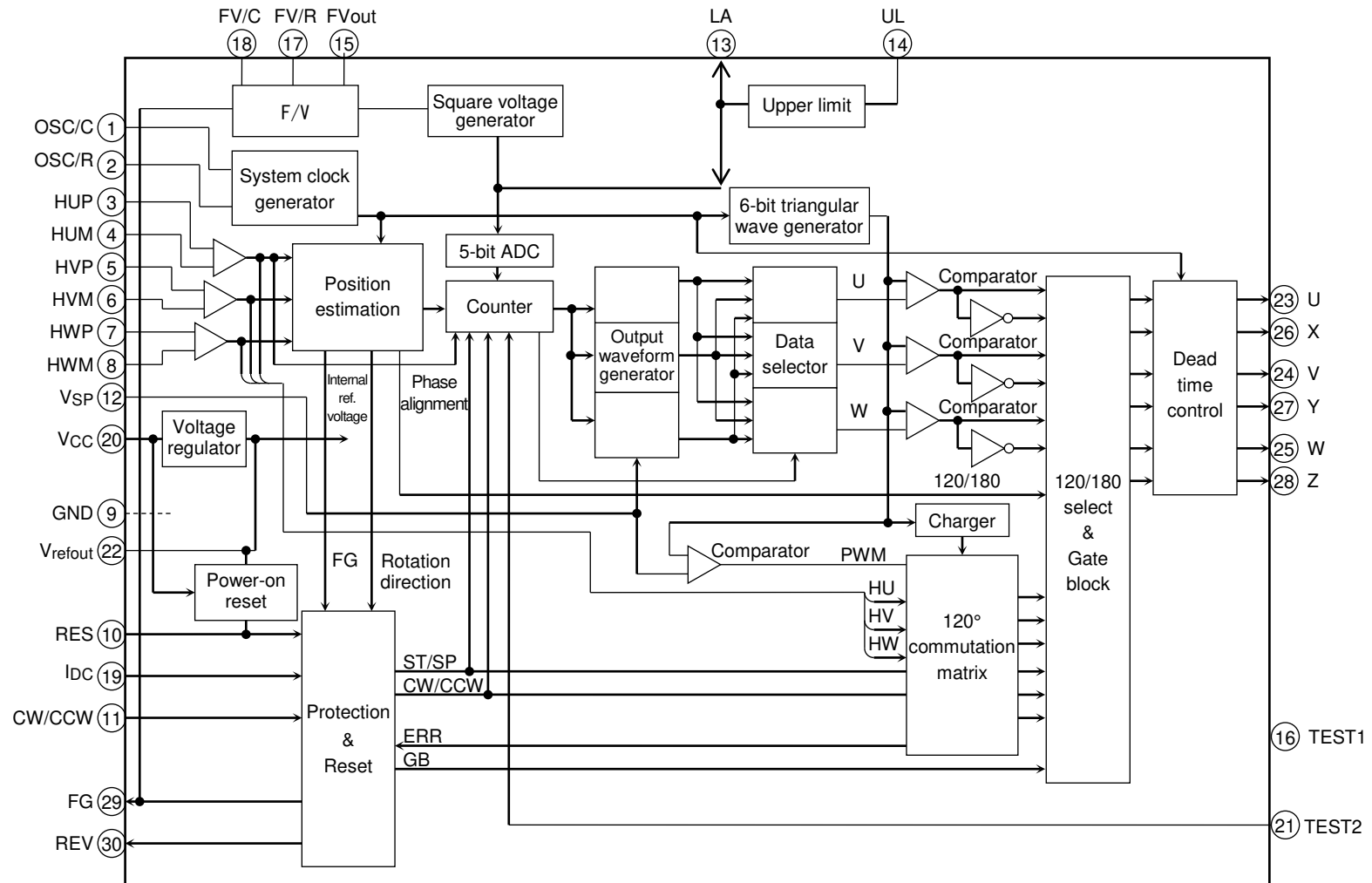

In the above block diagram, part of the functional blocks or constants may be omitted or simplified for explanatory purposes.

Pin Configuration

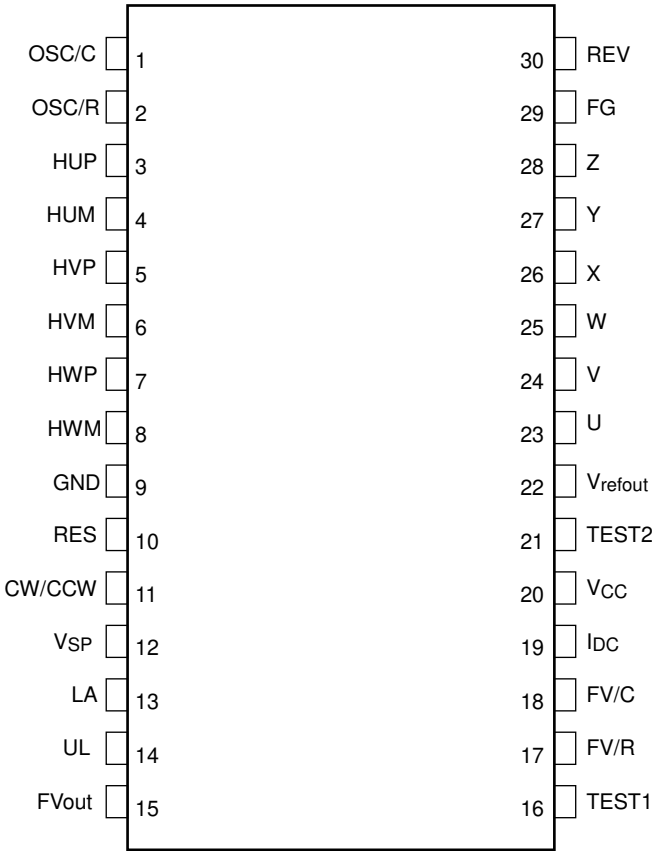

Pin Description

Pin No.	Symbol	Function	Description	
1	OSC/C	Oscillator capacitor	CR oscillation	
2	OSC/R	Oscillator resistor		
3	HUP	Position signal input, U	Gate block protection is activated when position signal (UVW) = HHH or LLL. These inputs have internal pull up resistors and digital filters (≈ 500 ns)	
4	HUM			
5	HVP	Position signal input, V		
6	HVM			
7	HWP	Position signal input, W		
8	HWM			
9	GND	Ground		—
10	RES	Reset input		L: Runs the motor. H: Stops the motor. (The commutation output signals are forced Low.) The RES input has an internal pull down resistor.
11	CW/CCW	Clockwise/counterclockwise rotation	L: Clockwise rotation H: Counterclockwise rotation The CW/CCW input has an internal pull up resistor.	
12	V _{SP}	Voltage command input	The V _{SP} input has an internal pull down resistor.	
13	LA	Lead angle (LA) control input / output	The LA input / output allows the lead angle to be adjusted between 0° and 58 in 32 separate steps.	
14	UL	Upper limit for LA	The UL input determines the upper limit for the lead angle (UL = 0 to 5.0 V).	
15	FV _{out}	F/V output voltage	F/V	
16	TEST1	TEST terminal	TEST1 terminal has an internal pull down resistor. TEST1 terminal must be left open or connected to GND.	
17	FV/R	F/V resistor	F/V	
18	FV/C	F/V capacitor	F/V	
19	I _{DC}	Current limit control input	The DC-link current is applied to the I _{DC} input. The reference voltage is 0.5 V. The I _{DC} input has an internal RC filter (with a time constant of 1 μs) and a digital filter (with a time constant of 1 μs).	
20	V _{CC}	Power supply	V _{CC} = 7 to 16.5 V	
21	TEST2	Switch for generation of modulation wave	TEST2 terminal has an internal pull down resistor. L or Open: every electrical angle of 360°, H: every electrical angle of 60°.	
22	V _{refout}	Reference voltage output	5 V (typ.), 30 mA (max) A capacitor for oscillation prevention is connected to the V _{refout} output.	
23	U	Commutation signal output U, (U high-side)	High-active	
24	V	Commutation signal output V, (V high-side)		
25	W	Commutation signal output W, (W high-side)		
26	X	Commutation signal output X, (U low-side)		
27	Y	Commutation signal output Y, (V low-side)		
28	Z	Commutation signal output Z, (W low-side)		
29	FG	FG signal output	The FG output gives three pulses per electrical revolution.	
30	REV	Reverse rotation detection signal	The REV output is used to detect an occurrence of reverse rotation.	

Input/Output Equivalent Circuits

Equivalent circuit diagrams may be partially omitted or simplified for explanatory purposes.

Pin	Symbol	Input/Output Signal	Internal Circuit
Position signal input, U Position signal input, V Position signal input, W	HUP HUM HVP HVM HWP HWM	Analog Hysteresis: ± 7.5 mV (typ.)	
Clockwise/counterclockwise rotation L: CW H: CCW	CW/CCW	Digital L: 0.8 V (max) H: $V_{refout} - 1$ V (min)	
Reset input L: Runs the motor. H: Stops the motor. (Reset)	RES	Digital L: 0.8 V (max) H: $V_{refout} - 1$ V (min)	
Voltage command signal 1.0 V < V_{SP} ≤ 2.1 V Refresh operation (The X, Y and Z pins have a conduction duty cycle of 8%.)	V_{SP}	Analog V_{SP} voltage range: 0 to 10 V When 5.7 V ≤ V_{SP} ≤ 7.3 V, the PWM duty cycle is fixed at 92% (typ.). When 8.2 V ≤ V_{SP} ≤ 10 V, the TB6631FNG is put in test mode.	
Lead angle control input 0 V: 0° 5 V: 58° (5-bit ADC)	LA	To fix the lead angle externally, UL and V_{refout} should be connected together. The lead angle is linearly determined according to the voltage applied to the LA input. LA voltage range: 0 to 5.0 V (V_{refout}) If $LA \geq V_{refout}$, the commutation occurs with the maximum lead angle of 58°. When configured for auto lead angle control, the LA input should be left open. At this time, the LA input can be used to check the lead angle in real time.	
Upper limit for LA	UL	If the voltage applied to the LA input exceeds the upper limit set by this input, it is clipped to limit the lead angle. UL = 0 to 5.0 V	

Pin	Symbol	Input/Output Signal	Internal Circuit
Current limit control input	IDC	Analog filter time constant: 1 μ s (typ.) Digital filter time constant: 1 μ s (typ.) Gate block protection is activated when the IDC voltage exceeds 0.5 V. (It is deactivated after a carrier cycle.) If IDC is left unconnected, all the commutation outputs are disabled.	
Reference voltage output	Vrefout	5 \pm 0.5 V (30 mA (max))	
Reverse rotation detection signal	REV	Digital Push-pull output (\pm 1 mA (max))	
FG signal output	FG	Digital Push-pull output (\pm 1 mA (max)) The FG output gives three pulses per electrical revolution.	
Commutation signal output, U Commutation signal output, V Commutation signal output, W Commutation signal output, X Commutation signal output, Y Commutation signal output, Z	U V W X Y Z	Digital Push-pull outputs (\pm 2 mA (max)) L: 0.78 V (max) H: Vrefout - 0.78 V (min)	

Pin	Symbol	Input/Output Signal	Internal Circuit
<p>F/V output voltage (Connecting to capacitor)</p>	<p>FVout</p>	<p>Analog outputs</p>	
<p>Select input for generation of modulation wave L: every electric angle of 360° H: every electric angle of 60°</p>	<p>TEST2</p>	<p>Digital input L or Open: 0.8 V (max) H: $V_{refout} - 1$ V (min)</p>	

Absolute Maximum Ratings (Ta = 25°C)

Characteristics	Symbol	Rating	Unit
Supply voltage	V _{CC}	18	V
Input voltage	V _{IN (1)}	-0.3 to V _{CC} (Note 1)	V
	V _{IN (2)}	-0.3 to V _{refout} + 0.3 (Note 2)	
Commutation output current	I _{OUT}	2	mA
V _{refout} output current	I _{refout}	30 (Note 3)	mA
Operating temperature	T _{opr}	-30 to 115	°C
Storage temperature	T _{stg}	-55 to 150	°C

Note 1: V_{IN (1)} pins: VSP, LA, and UL

Note 2: V_{IN (2)} pins: HUP, HVP, HWP, HUM, HVM, HWM, CW/CCW, I_{DC}, and TEST2

Note 3: Since the V_{refout} pin delivers a maximum output current of 30 mA, care should be exercised to the output impedance.

Operating Ranges (Ta = 25°C)

Characteristics	Symbol	Min	Typ.	Max	Unit
Supply voltage	V _{CC}	7	15	16.5	V
Oscillation frequency	f _{osc}	3	4.5	6	MHz

Electrical Characteristics (Ta = 25°C, Vcc = 15 V)

Characteristics		Symbol	Test Condition	Min	Typ.	Max	Unit
Supply current		ICC	Vrefout = OPEN	—	5	8	mA
Input current	IIN (1)-1	VIN = 5 V	LA	—	25	50	μA
	IIN (1)-2	VIN = 5 V	VSP	—	35	70	
	IIN (2)-1	VIN = 5 V	RES	—	50	100	
	IIN (2)-2	VIN = 0 V	CW/CCW	-100	-50	—	
	IIN (2)-3	VIN = 5 V	TEST2	—	100	200	
Input voltage	VIN	High	CW/CCW, RES, and TEST2	Vrefout -1	—	Vrefout	V
		Low		—	—	0.8	
	VSP	T	Forced 120° commutation conduction duty cycle = 92% -3.8 μs (typ.)	8.2	—	10	
		H	PWM duty cycle = 92%	5.1	5.4	5.7	
		M	Refresh → Motor startup	1.8	2.1	2.4	
L		Commutation off → Refresh	0.7	1.0	1.3		
Hall effect inputs	Input sensitivity	VS	Differential inputs	100	—	—	mVpp
	Common-mode input voltage	VW		1.5	—	3.5	V
	Input hysteresis	VH (1)	(Note)	±5.5	±7.5	±9.5	mV
Input delay time	TDT	Hall inputs	(fosc = 4.5 MHz)	—	1.0	—	μs
	TDC	IDC	(fosc = 4.5 MHz)	—	2.5	—	
Output voltage	VOUT (H)-1	IOUT = 2 mA	U, V, W, X, Y, Z	Vrefout - 0.78	Vrefout - 0.3	—	V
	VOUT (L)-1	IOUT = -2 mA	U, V, W, X, Y, Z	—	0.3	0.78	
	VREV (H)	IOUT = 1 mA	REV	Vrefout - 1.0	Vrefout - 0.2	—	
	VREV (L)	IOUT = -1 mA	REV	—	0.2	1.0	
	VFG (H)	IOUT = 1 mA	FG	Vrefout - 1.0	Vrefout - 0.2	—	
	VFG (L)	IOUT = -1 mA	FG	—	0.2	1.0	
	Vrefout	IOUT = 30 mA	Vrefout	4.5	5.0	5.5	
Output leakage current	IL (H)	VOUT = 0 V	U, V, W, X, Y, Z	—	0	10	μA
	IL (L)	VOUT = Vrefout	U, V, W, X, Y, Z	—	0	10	
Dead time (cross conduction protection)	TOFF	(fosc = 4.5 MHz), IOUT = ± 2 mA		1.7	2.0	2.3	μs
Current sensing	VDC	IDC		0.46	0.5	0.54	V
Setting error of auto lead angle	VLA	FG IN = 150 Hz FV/C: 820 pF FV/R: 220 kΩ, 0.22 μF FVout: 0.1 μF		0.82	1.02	1.22	V
LA limit setting error	ΔU	UL = 2.0 V		-20	—	20	mV
Lead angle correction	TLA (0)	LA = 0 V or open, Hall inputs = 100 Hz		—	0	—	°
	TLA (2.5)	LA = 2.5 V, Hall inputs = 100 Hz		28	32	35	
	TLA (5)	LA = 5 V, Hall inputs = 100 Hz		52	57	60	
VCC monitor	VCC (H)	Output turn-on threshold		4.1	4.4	4.7	V
	VCC (L)	Output turn-off threshold		3.7	4.0	4.3	
	VH	Input hysteresis width		—	0.5	—	
PWM oscillation frequency (carrier frequency)	FC (20)	OSC/C = 330 pF, OSC/R = 9.1 kΩ		18	20	22	kHz
	FC (18)	OSC/C = 330 pF, OSC/R = 10 kΩ		16.2	18	19.8	
Maximum conduction duty cycle	TON (max)	OSC/C = 330 pF, OSC/R = 10 kΩ VSP = 5.7 V		89	92	95	%

Note: Not tested in production

Functional Description

1. Basic Operation

During startup, the motor is driven by square-wave commutation signals that are generated according to the position signals. When the position signals indicate a rotational speed (f) of 1 Hz, the TB6631FNG estimates the rotor positions from the position signals and modulate them. The TB6631FNG then generates sine-wave by comparing the modulated signals against a triangular waveform.

From startup to 1 Hz: square-wave drive (120° commutation);

Over 1 Hz: Sine-wave PWM drive (180° commutation); f will be approximately 1 Hz when $f_{osc} = 4$ MHz

2. Voltage Command (VSP) Signal and Bootstrap Voltage Regulation

- (1) When $V_{SP} \leq 1.0$ V:
The commutation signal outputs are disabled (i.e., gate protection is activated).
- (2) When 1.0 V $< V_{SP} \leq 2.1$ V:
The low-side commutation signal outputs are turned on at a regular (PWM carrier) frequency. (The conduction duty cycle is approx. 8%.)
- (3) When 2.1 V $< V_{SP} \leq 7.3$ V:
During sine-wave PWM drive, the commutation signal outputs directly appear externally. During square-wave drive, the low-side transistors are forced on at a regular (PWM carrier) frequency. (The conduction duty cycle is approx. 8%.)
- (4) When 8.2 V $\leq V_{SP} \leq 10$ V (test mode):
The TB6631FNG is forced into square-wave drive mode. The drive mode switches from sine-wave PWM to square-wave drive at a V_{SP} of 7.9 V typical. The conduction duty cycle during square-wave drive is calculated as $PWM_carrier_frequency \times 92\% - 3.8 \mu s$ typical.

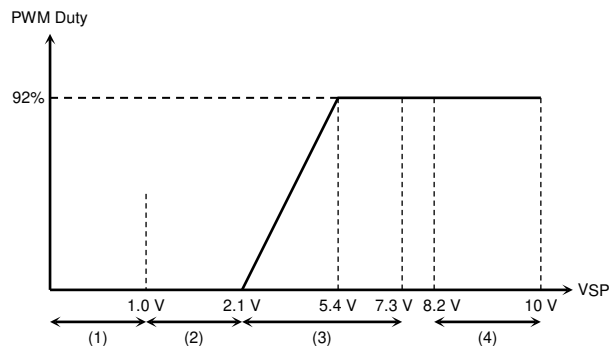

3. Dead Time Insertion (cross conduction protection)

To prevent a short-circuit between external low-side and high-side power elements during sine-wave PWM drive, a dead time is digitally inserted between the turn-on of one side and the turn-off of the other side. (The dead time is also implemented at the full duty cycle during square-wave drive.)

$$T_{OFF} = 9/f_{osc}$$

$T_{OFF} \approx 2.0 \mu s$ when $f_{osc} = 4.5$ MHz, where f_{osc} is the reference clock frequency (i.e., CR oscillator frequency).

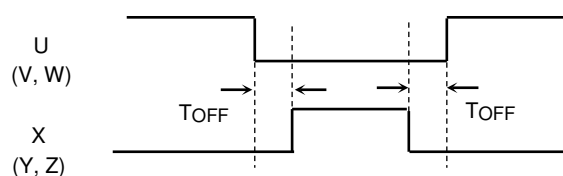

4. Lead Angle Control

The lead angle can be adjusted between 0° and 58° in 32 separate steps according to the induced voltage level on the LA input / output, which works with 0 to 5 V.

0 V = 0°

5 V = 58° (A lead angle of 58° is assumed when the LA voltage exceeds 5 V.)

(Value is design target)

Step	LA [V]	Lead angle [deg]	Step	LA [V]	Lead angle [deg]	Step	LA [V]	Lead angle [deg]
0	0.000	0.000	11	1.719	20.625	22	3.438	41.250
1	0.156	1.875	12	1.875	22.500	23	3.594	43.125
2	0.313	3.750	13	2.031	24.375	24	3.750	45.000
3	0.469	5.625	14	2.188	26.250	25	3.906	46.875
4	0.625	7.500	15	2.344	28.125	26	4.063	48.750
5	0.781	9.375	16	2.500	30.000	27	4.219	50.625
6	0.938	11.250	17	2.656	31.875	28	4.375	52.500
7	1.094	13.125	18	2.813	33.750	29	4.531	54.375
8	1.250	15.000	19	2.969	35.625	30	4.688	56.250
9	1.406	16.875	20	3.125	37.500	31	4.844	58.125
10	1.563	18.750	21	3.281	39.375	32	5.000	58.125

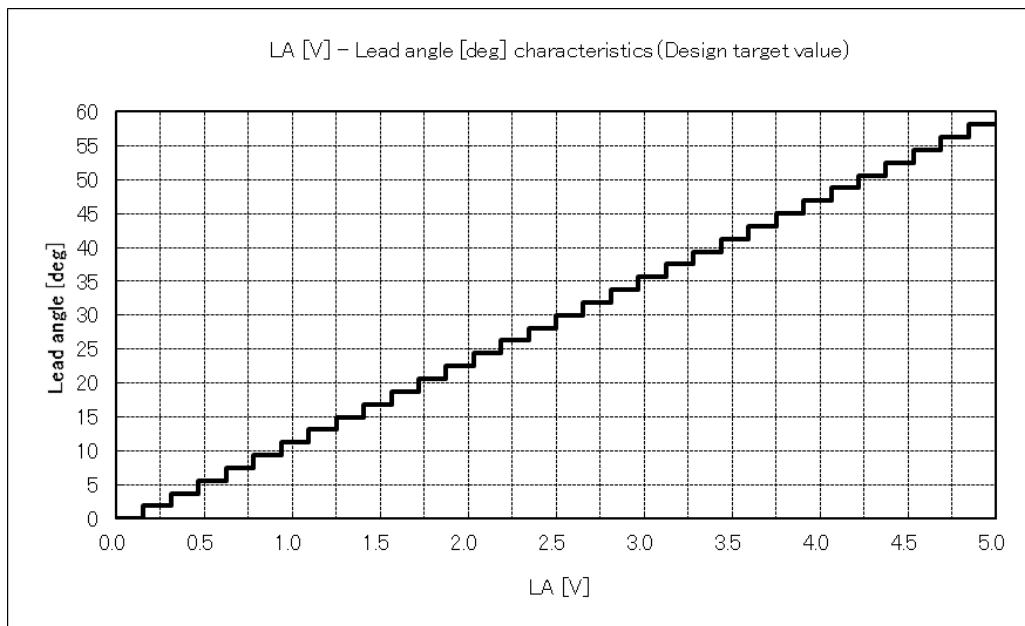

Auto Lead Angle function

For auto lead angle function, set external component as below.
Then LA pin output voltage controlled internal automatically by FG frequency.

Pin No.	Symbol	External component	Remarks
13	LA	C(LA)	Capacitor for stability
15	FVout	C(FVout)	Capacitor for stability
17	FV/R	R(FV/R)	Resistor for setting coefficient of square curve
		C(FV/R)	Capacitor for stability
18	FV/C	C(FV/C)	Capacitor for setting coefficient of square curve

<Application circuit example>

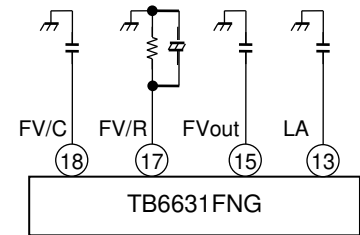

<Reference data>

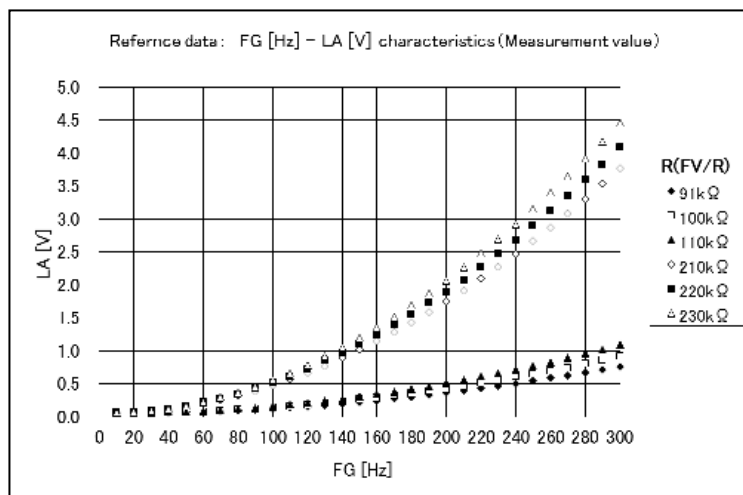

Reference data (Measurement value)

R(FV/R)	91 kΩ	100 kΩ	110 kΩ	210 kΩ	220 kΩ	230 kΩ
C(FV/C)	820pF	820pF	820pF	820pF	820pF	820pF
FG [Hz]	LA [V]					
10	0.06	0.06	0.06	0.07	0.07	0.07
20	0.07	0.07	0.07	0.08	0.08	0.08
30	0.07	0.07	0.07	0.09	0.10	0.10
40	0.07	0.07	0.07	0.12	0.13	0.12
50	0.08	0.07	0.08	0.16	0.17	0.17
60	0.08	0.08	0.09	0.20	0.22	0.23
70	0.09	0.09	0.10	0.26	0.28	0.30
80	0.10	0.11	0.12	0.32	0.35	0.37
90	0.11	0.12	0.14	0.40	0.43	0.46
100	0.13	0.14	0.16	0.48	0.52	0.56
110	0.14	0.16	0.19	0.58	0.62	0.67
120	0.16	0.18	0.22	0.68	0.73	0.79
130	0.18	0.21	0.24	0.78	0.85	0.92
140	0.20	0.24	0.28	0.90	0.98	1.05
150	0.23	0.26	0.31	1.02	1.11	1.20

Reference data (Measurement value)

R(FV/R)	91 kΩ	100 kΩ	110 kΩ	210 kΩ	220 kΩ	230 kΩ
C(FV/C)	820pF	820pF	820pF	820pF	820pF	820pF
FG [Hz]	LA [V]					
160	0.25	0.29	0.35	1.15	1.25	1.35
170	0.28	0.33	0.38	1.29	1.40	1.52
180	0.31	0.36	0.43	1.44	1.56	1.70
190	0.34	0.40	0.47	1.59	1.73	1.88
200	0.37	0.43	0.51	1.75	1.90	2.07
210	0.40	0.47	0.56	1.92	2.08	2.27
220	0.44	0.51	0.61	2.10	2.28	2.48
230	0.47	0.56	0.66	2.28	2.47	2.70
240	0.51	0.61	0.72	2.47	2.68	2.92
250	0.55	0.65	0.78	2.67	2.90	3.15
260	0.59	0.70	0.83	2.88	3.12	3.40
270	0.63	0.75	0.90	3.09	3.36	3.65
280	0.68	0.80	0.96	3.30	3.59	3.91
290	0.72	0.86	1.03	3.54	3.83	4.18
300	0.77	0.92	1.10	3.77	4.08	4.45

Lead Angle by external input function

For input to LA pin by external voltage, set external component as below.

Pin No.	Symbol	External component	Remarks
13	LA	—	LA pin: external input voltage
15	FVout	None or C(FVout)	—
17	FV/R	Connect to GND	—
18	FV/C	None	—

<Application circuit example>

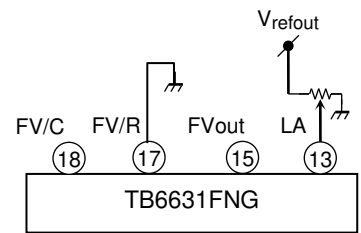

5. PWM Carrier Frequency

The triangular waveform generator provides a carrier frequency of $f_{osc}/252$ necessary for PWM generation. (The triangular wave is also used to force the switch-on of low-side commutation signal outputs during square-wave drive.)

Carrier frequency = $f_{osc}/252$ (Hz),
 where f_{osc} = reference clock (CR oscillator) frequency

6. Reverse Rotation Signal

This feature provides the rotational direction of the motor every 360 electrical degrees. A Low on the REV pin indicates 180° commutation mode (with Hall inputs of ≥ 1 Hz).

CW/CCW Pin	Actual Motor Rotation Direction	REV Pin
Low (CW)	CW (forward)	Low
	CCW (reverse)	High
High (CCW)	CW (forward)	High
	CCW (reverse)	Low

7. Protection-Related Input Pins

Overcurrent protection (IDC pin)

If the voltage of the DC-link current exceeds the internal reference voltage, the commutation signals are forced Low. Overcurrent protection is disabled after every carrier period.

Reference voltage = 0.5 V (typ.)

(5) Gate block protection (RES pin)

When the RES input is High, the commutation outputs are disabled. When the RES input is then set Low or open, the commutation outputs are re-enabled.

Any irregular conditions of the motor should be detected by external hardware; such indications should be presented to the RES input.

RES Pin	Commutation Output Signals (U, V, W, X, Y, Z)
High	Low
Low or open	The motor can be driven.

(When RES = High, charging of the bootstrap capacitor stops.)

(6) Internal protection

- Abnormal position signal protection

When the position signal inputs (UVW) are all Highs or all Lows, the commutation outputs are forced off (i.e., set Low). When these inputs are then set to any other combination, the commutation outputs are re-enabled. (The all-High and all-Low conditions are Hall sensor outputs.)

- Under voltage lockout (VCC monitor)

While the power supply voltage is outside the rated range during power-on or power-off, the commutation outputs are set to the high-impedance state to prevent external power elements from damage due to short-circuits.

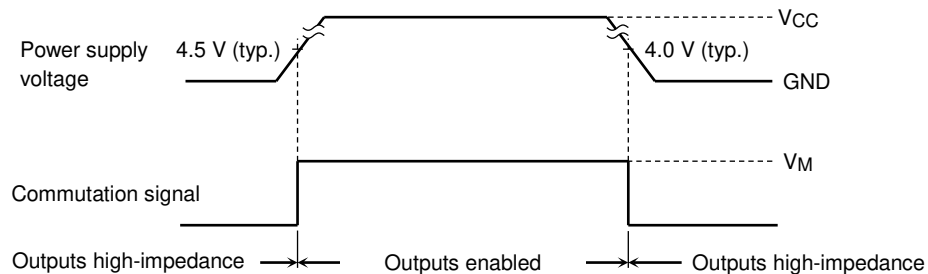

Operation Flow

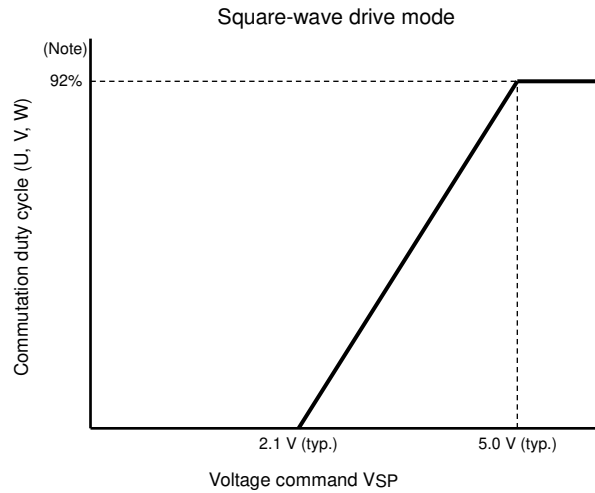
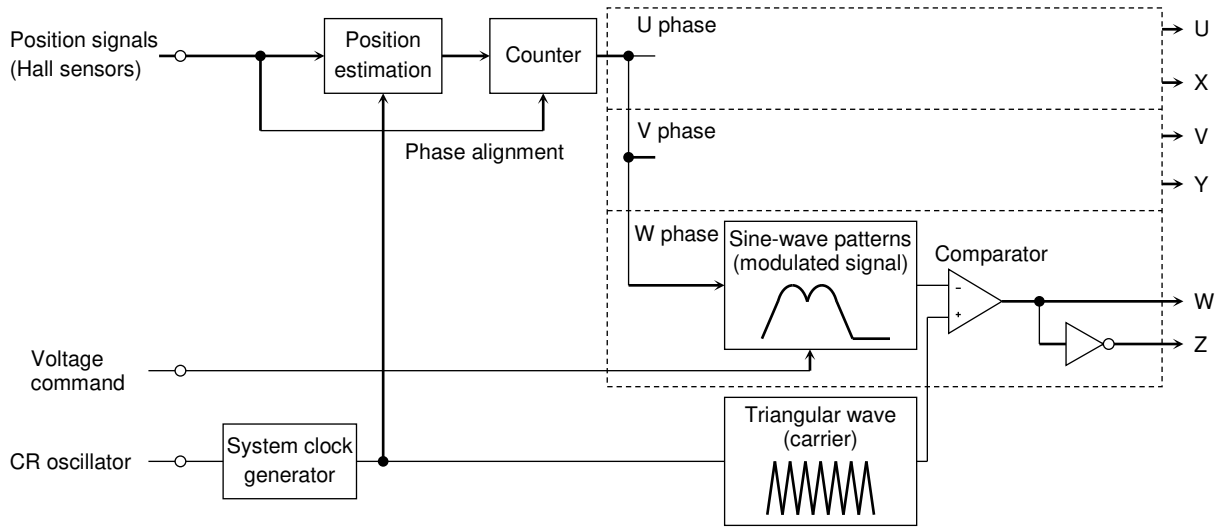

Note: The conduction period is reduced by the dead time. (carrier frequency × 92% - TD × 2)

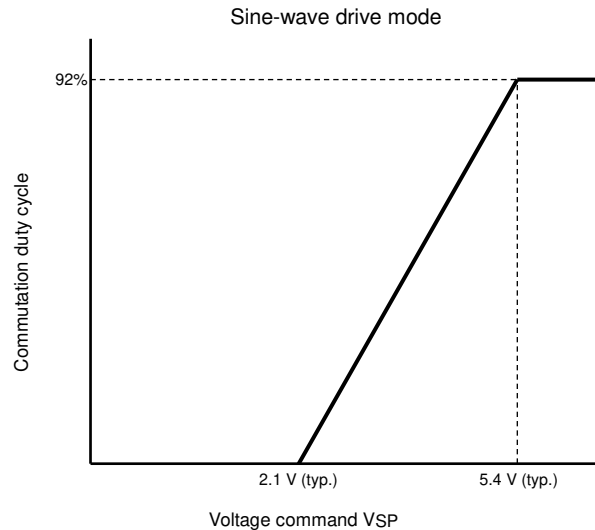

Generation Timing of Modulation Wave

Timing of generating modulation wave and the reset can be selected by the TEST2 terminal.

TEST2	Function
L	Generating modulation wave every electric angle of 360°
H	Generating modulation wave every electric angle of 60°

When TEST2 = L

The position signals from Hall sensors are modulated, and the modulated signals are then compared against a triangular waveform to generate a sinusoidal PWM waveform.

The counter measures the period from a given falling edge of the HU input to its next falling edge (360 electrical degrees). This period is then used as 360° phase data for the next modulation.

A total of 192 ticks comprise 360 electrical degrees; the length of a tick equals 1/192nds the time period of the immediately preceding 360° phase.

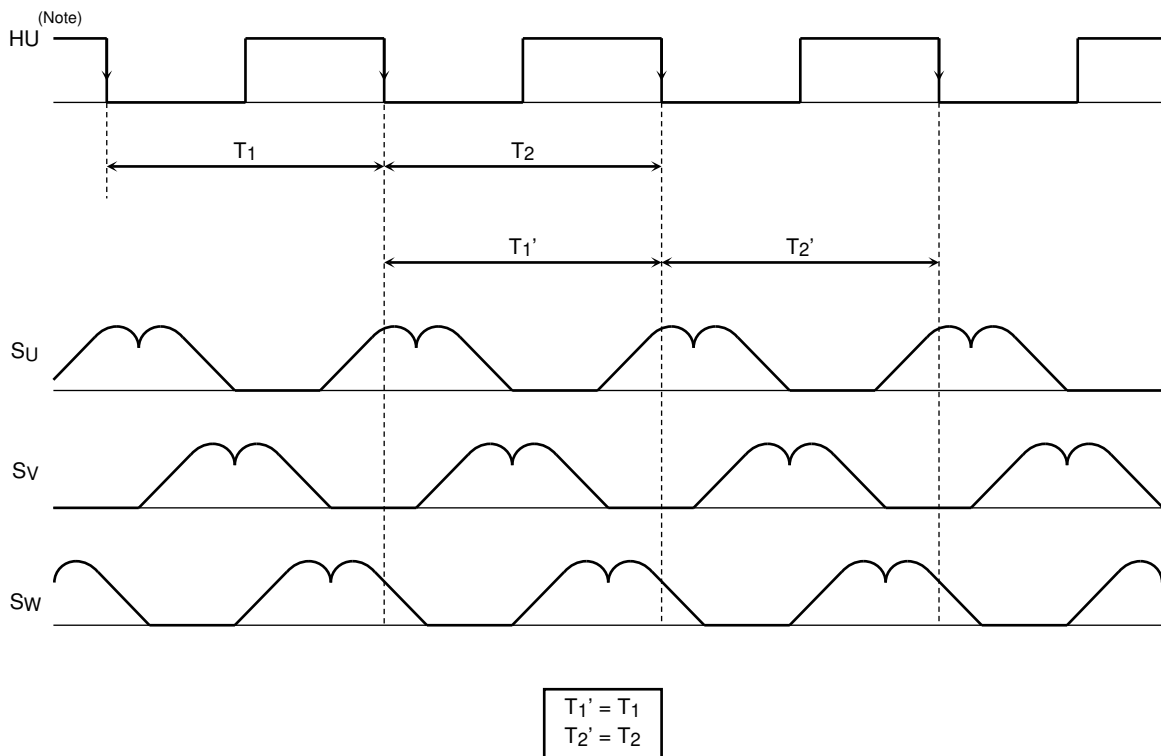

In the above diagram, the modulated waveforms have an interval (T_1') equal to the interval between a falling edge of HU to its next falling edge (T_1) of the previous cycle. If there is not an HU falling edge before T_1' ends, T_2' becomes equal to T_1' until the next falling edge of HU.

Modulation is reset on each falling edge of HU, which occurs every 360 electrical degrees. While the motor is accelerating or decelerating, the modulated waveform becomes discontinuous upon each reset.

Note: In the above diagram, HU is shown as square waveforms for the sake of simplicity.

When TEST2 = H

The position signals from Hall sensors are modulated, and the modulated signals are then compared against a triangular waveform to generate a sinusoidal PWM waveform.

The counter measures the period from a given rising (falling) edge of three hall signals to its next rising (falling) edge (60 electrical degrees). This period is then used as 60° phase data for the next modulation.

A total of 32 ticks comprise 60 electrical degrees; the length of a tick equals 1/32nds the time period of the immediately preceding 60° phase.

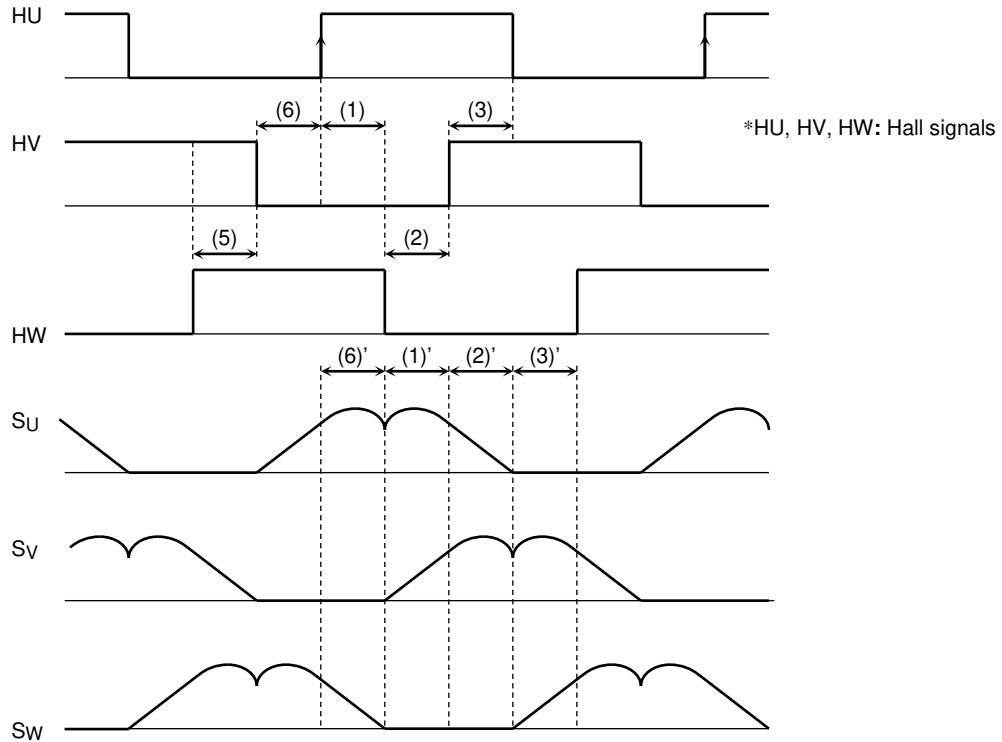

In the above diagram, the modulated waveforms have an interval ((1)') equal to the interval of 1/32 between a rising edge of HU to a falling edge of HW ((1)). And the modulated waveforms have an interval ((2)') equal to the interval of 1/32 between a falling edge of HW to a rising edge of HV ((2)). If there is not an HU rising edge before 32 ticks ends, (2)' becomes equal to (1)' until the next rising edge of HU.

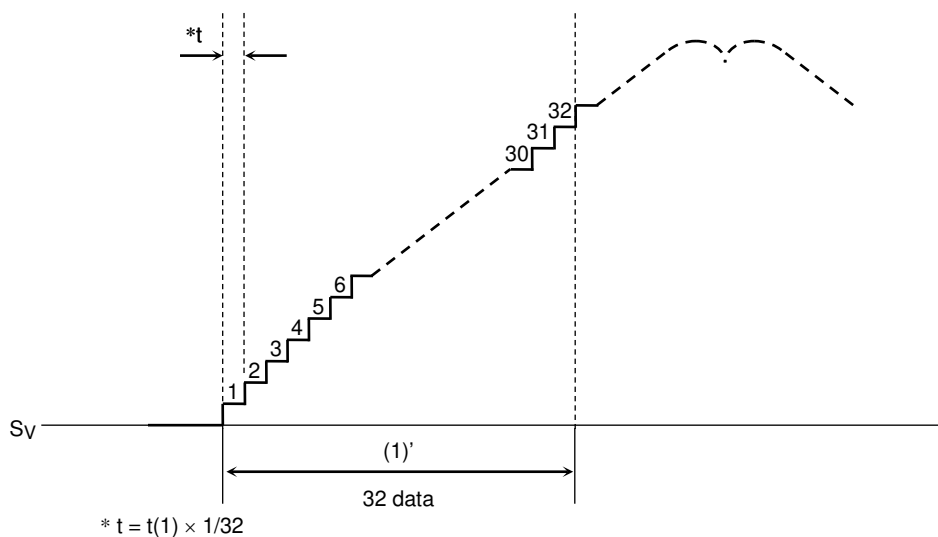

Phase of data and modulated waveform is adjusted for every zero cross of position detecting signal.

Modulation is reset on each rising and falling edge of position detecting signal, which occurs every 60 electrical degrees. While the hall signal is out of its position and the motor is accelerating or decelerating, the modulated waveform becomes discontinuous upon each reset.

Note: In the above diagram, HU is shown as square waveforms for the sake of simplicity.

Forward Rotation Timing Chart (CW/CCW = Low, LA = GND)

(Non-inverted hall signal inputs)

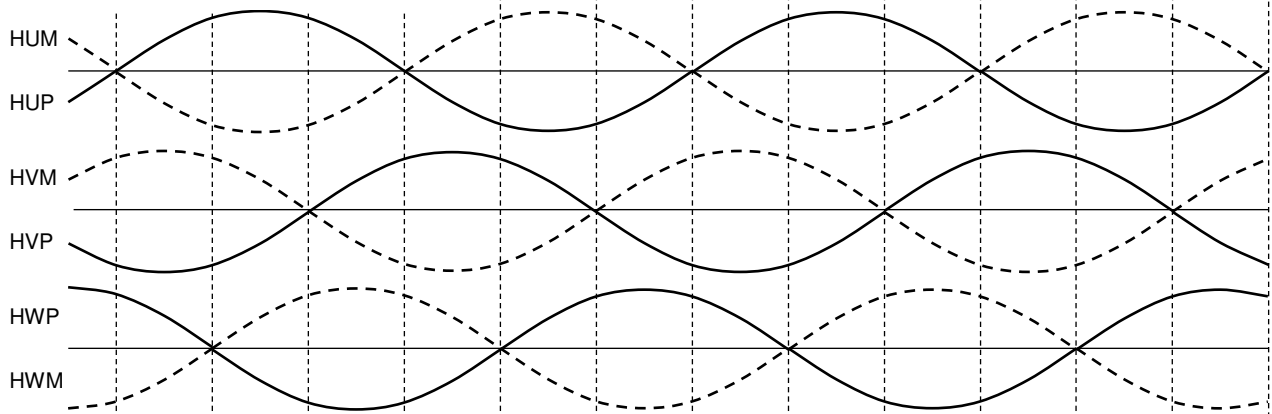

0 < Hall signals < 1 Hz
(120° commutation)

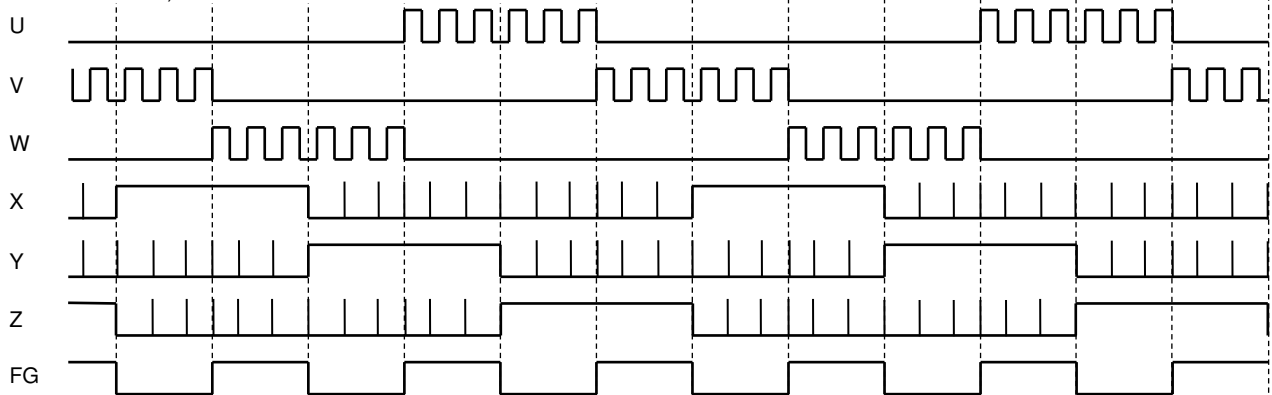

1 Hz < Hall signals
(180° commutation: Modulated waveforms)

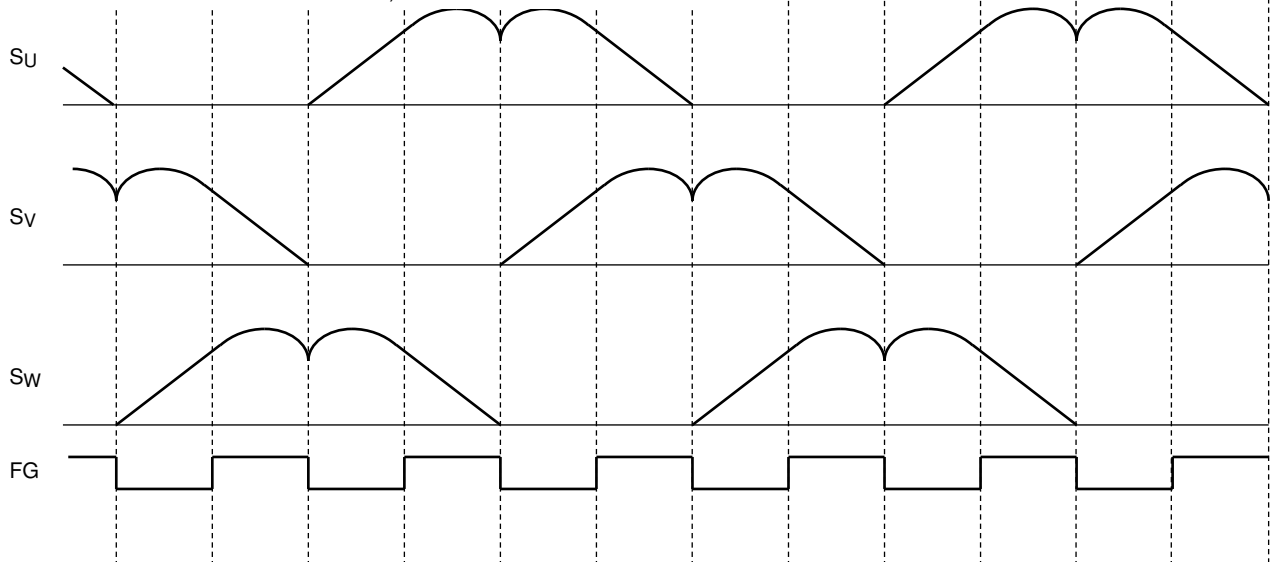

*: When the Hall input frequency is equal to or greater than 1 Hz (@ $f_{osc} = 4 \text{ MHz}$), lead angle control is activated according to the LA input.

The above timing chart is simplified to illustrate the function and behavior of the device.

Forward Rotation Timing Chart (CW/CCW = Low, LA = GND)

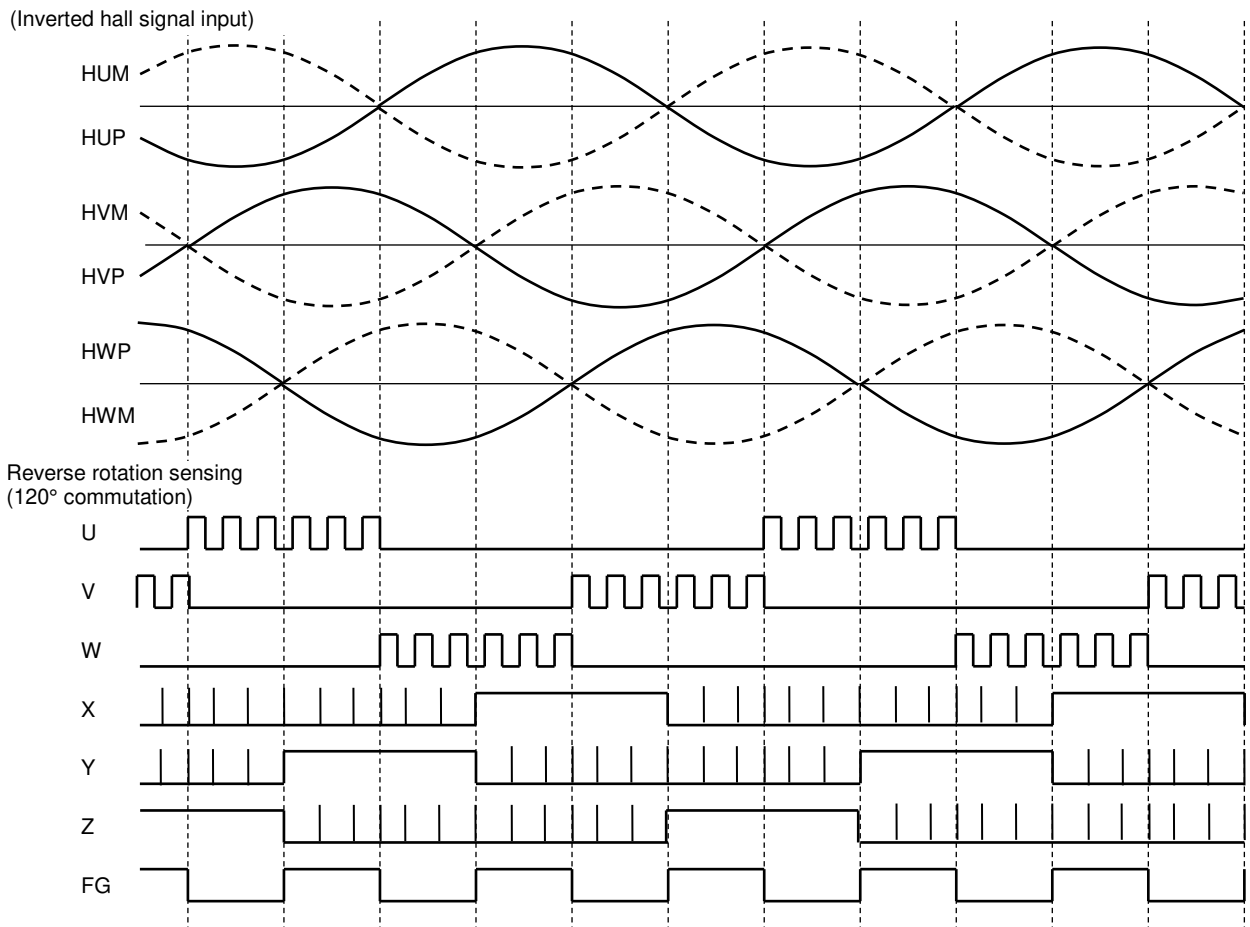

*: When CW/CCW = Low, inverted Hall signals put the TB6631FNG in 120° commutation mode with a lead angle of 0° (reverse rotation).

The above timing chart is simplified to illustrate the function and behavior of the device.

Reverse Rotation Timing Chart (CW/CCW = High, LA = GND)

(Inverted hall signal input)

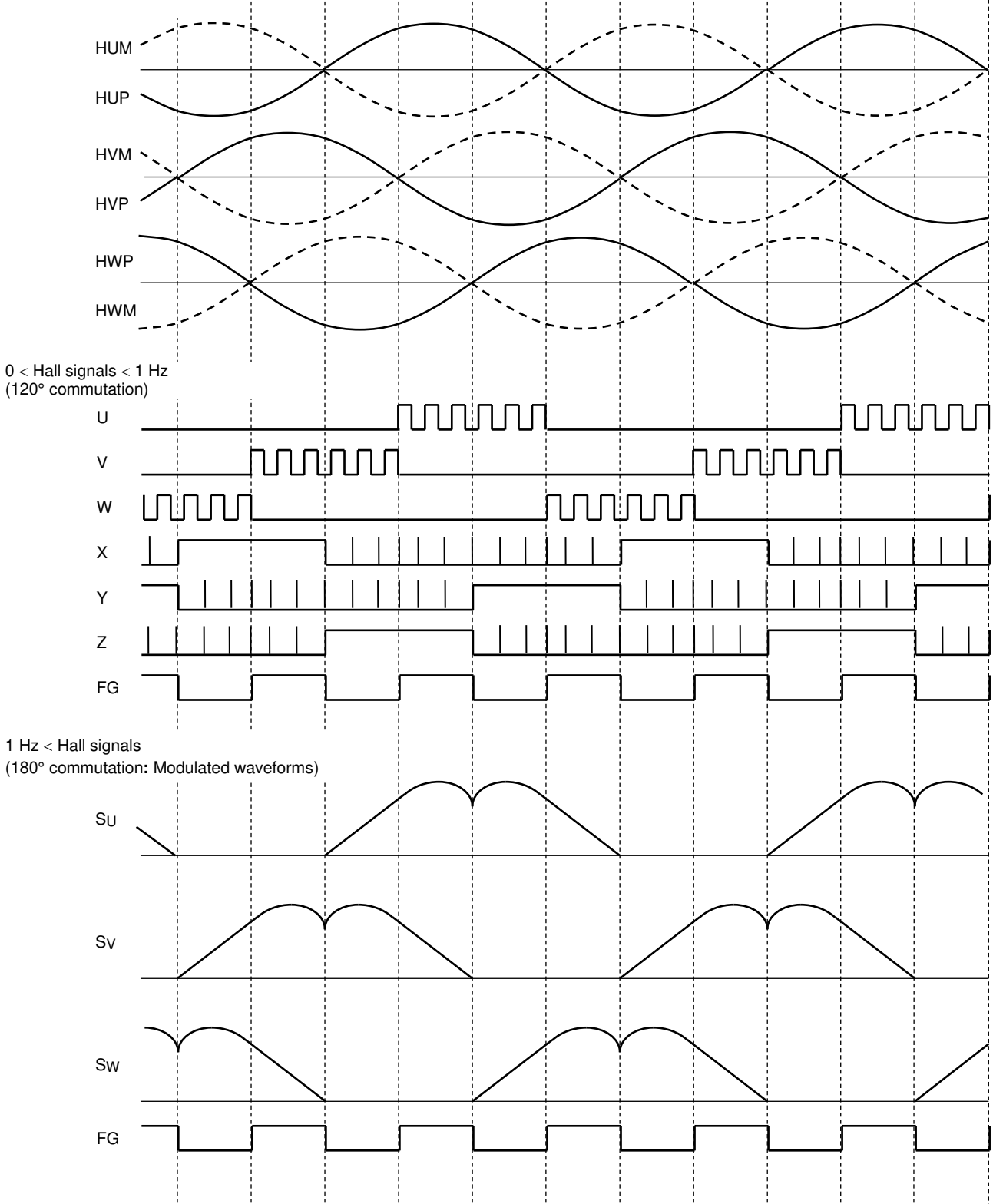

*: When the Hall input frequency is equal to or greater than 1 Hz (@ $f_{osc} = 4 \text{ MHz}$), lead angle control is activated according to the LA input.

The above timing chart is simplified to illustrate the function and behavior of the device.

Reverse Rotation Timing Chart (CW/CCW = High, LA = GND)

(Non-inverted hall signal input)

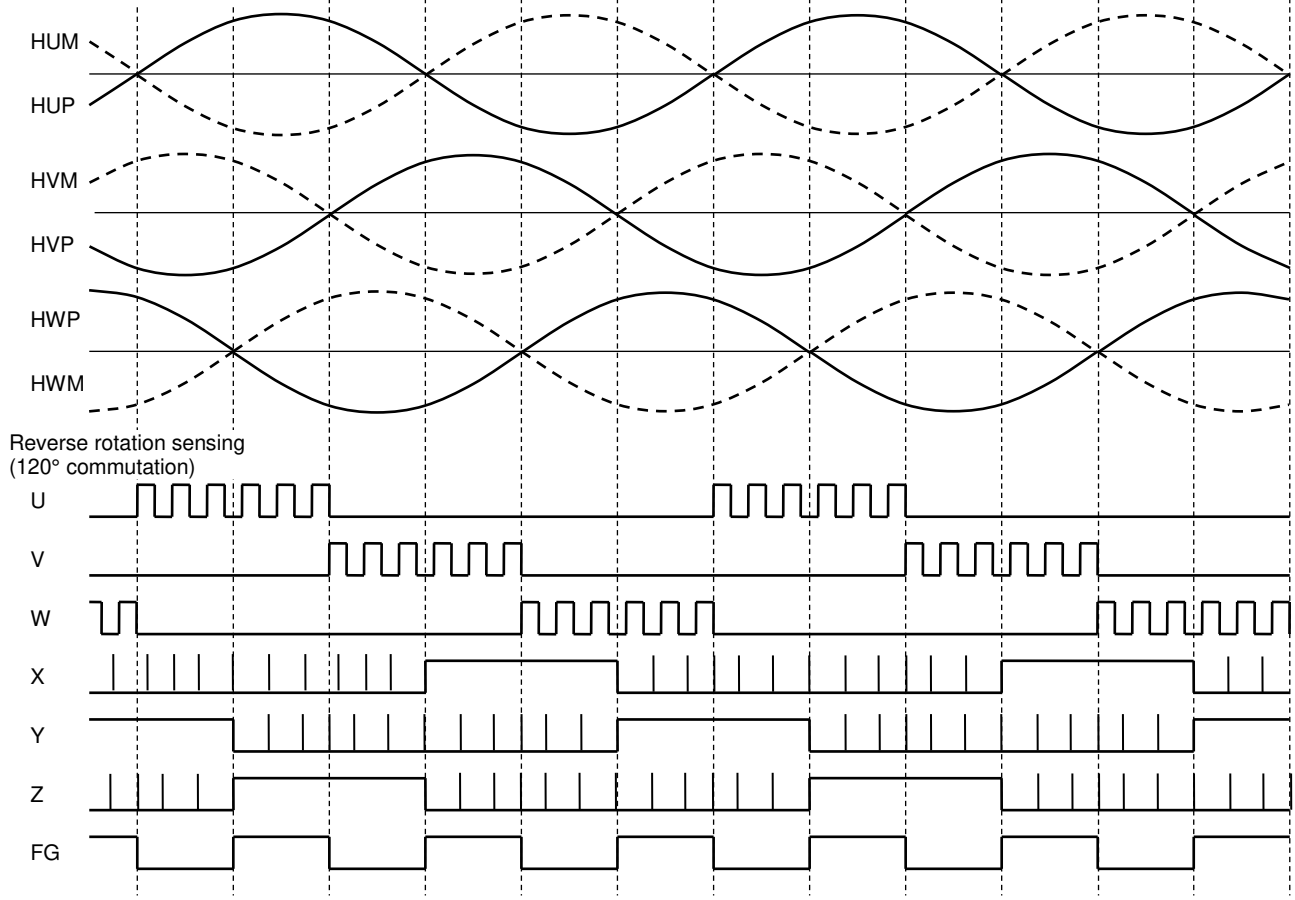

*: When CW/CCW = High, non-inverted Hall signals put the TB6631FNG in 120° commutation mode with a lead angle of 0° (reverse rotation).

The above timing chart is simplified to illustrate the function and behavior of the device.

Square-Wave Drive Waveform (CW/CCW = Low)

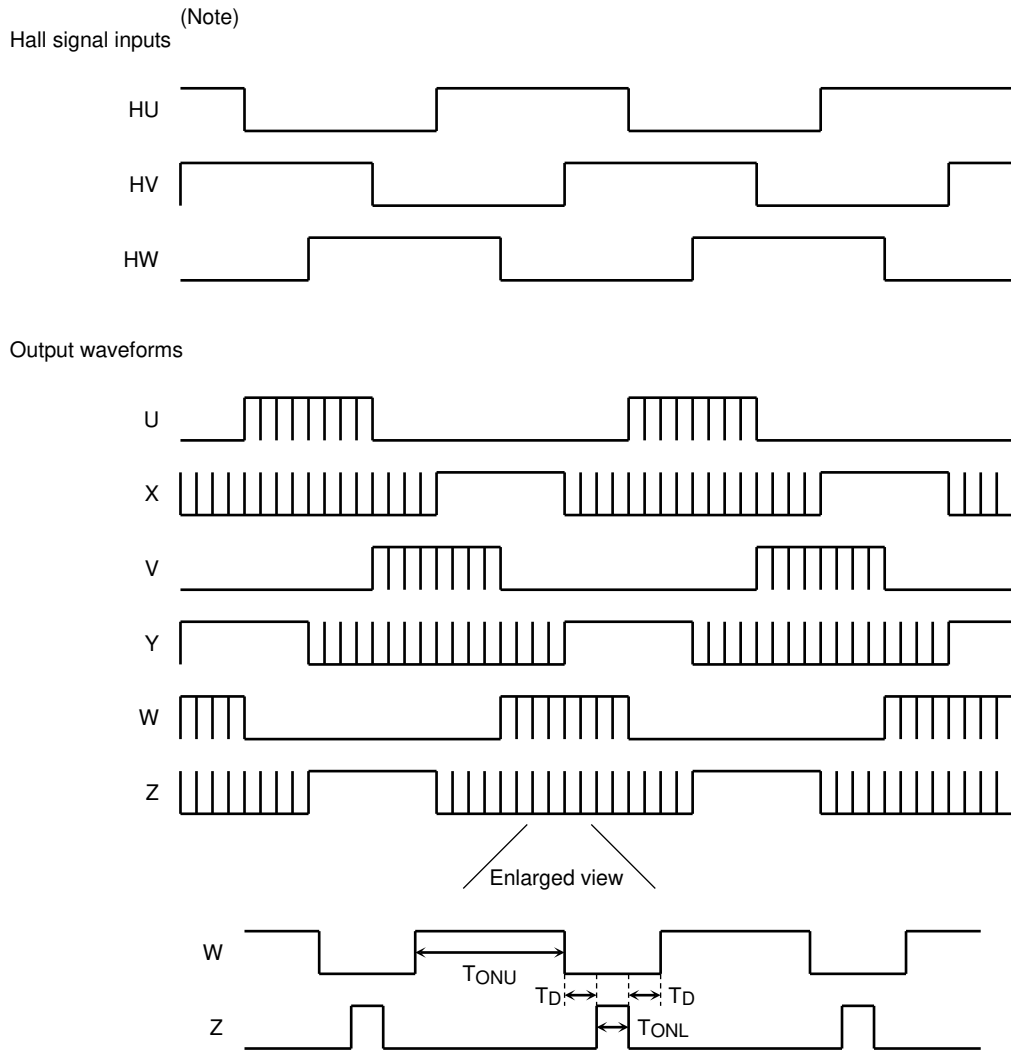

Note: Square waveforms are used in the above diagram for the sake of simplicity.

To obtain an adequate bootstrap voltage, the low-side outputs (X, Y and Z) are always turned on for eight percent of the carrier period (TONL) even during the off time of the low side in 120° commutation mode. As shown in the enlarged view, the high-side outputs (U, V and W) are turned off for a dead time period while the low-side outputs are on. (TD varies with the VSP input.)

$$\text{Carrier frequency} = f_{\text{osc}}/252 \text{ (Hz)} \qquad \text{Dead time: } T_D = 9/f_{\text{osc}} \text{ (s)} \text{ (VSP} \geq 5.0 \text{ V)}$$

$$T_{\text{ONL}} = \text{carrier_frequency} \times 8\% \text{ (s)} \text{ (Constant regardless of the VSP input)}$$

In square-wave drive mode, the changing of the motor speed is enabled, depending on the VSP voltage; the motor speed is determined by the duty cycle of TONU. (See the square-wave drive mode diagram on page 15.)

Note: At startup, the motor is driven by a square wave when the Hall signal frequency is 1 Hz or lower (@ $f_{\text{osc}} = 4$ MHz) and when the motor is rotating in the direction reverse to the settings of the TB6631FNG (REV = High).

Sine-Wave Drive Waveform (CW/CCW = Low)

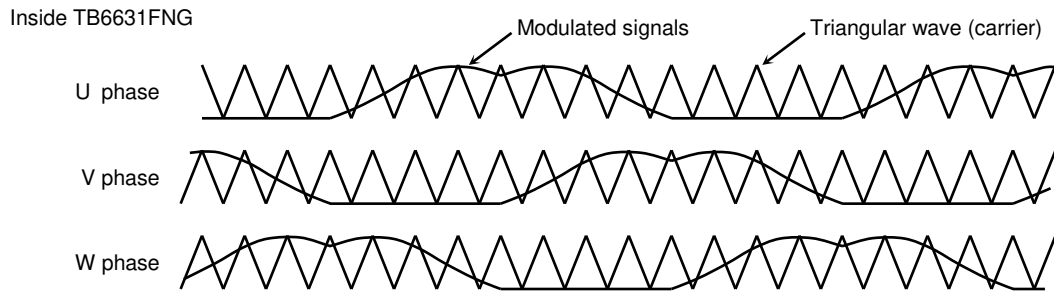

Output waveforms

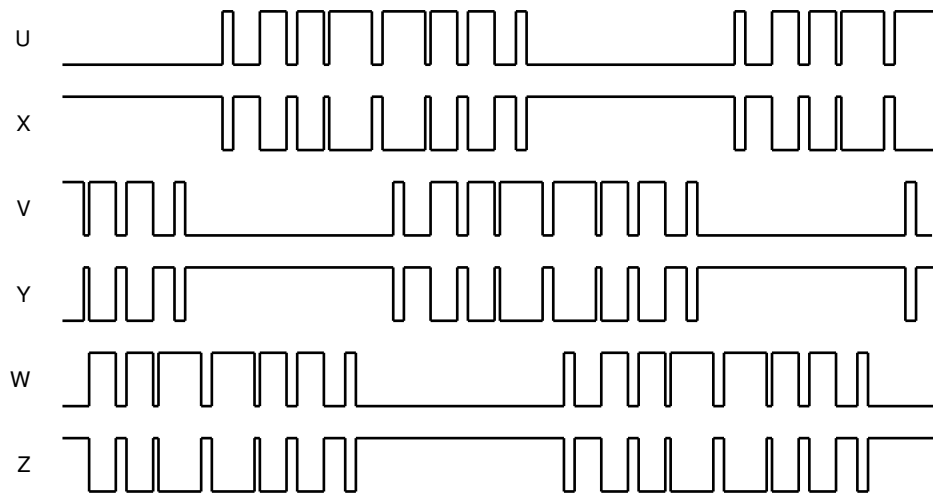

Phase voltage differences

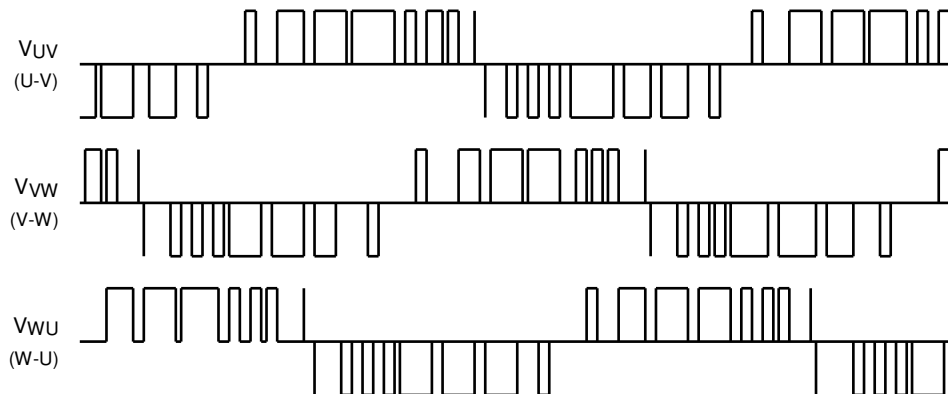

In sine-wave drive mode, the amplitude of the modulated signals varies with the VSP voltage, and the motor speed changes with the conduction duty cycle of the output waveforms. (See the sine-wave drive mode diagram on page 15.)

$$\text{Triangular wave frequency} = \text{carrier frequency} = f_{osc}/252 \text{ (Hz)}$$

Note: At startup, the motor is driven by a sine wave when the Hall signal frequency is 1 Hz or higher (@ $f_{osc} = 4$ MHz) and when the motor is rotating in the same direction as settings of the TB6631FNG (REV = Low).

Application Circuit Example

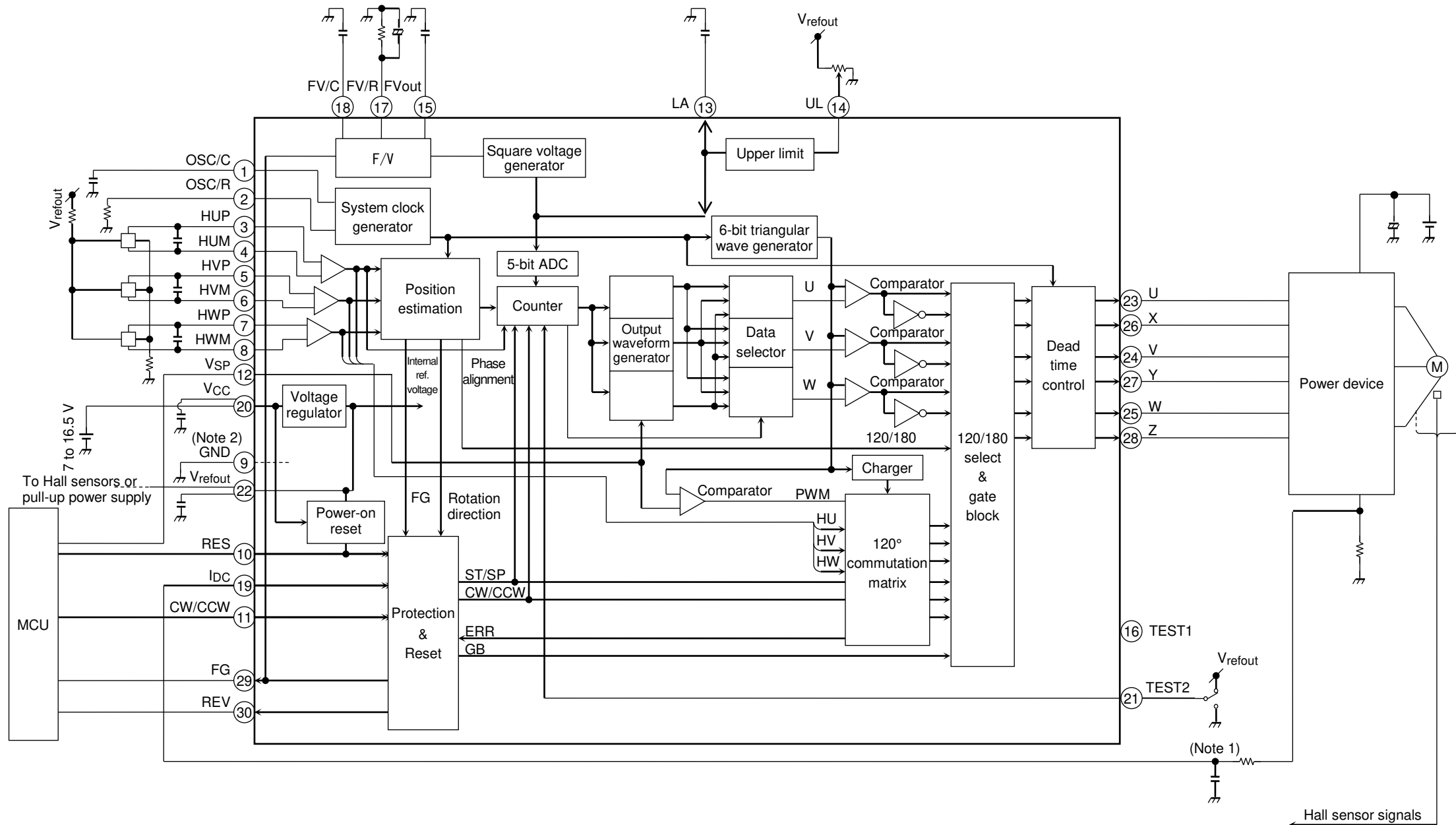

Note 1: Connect to ground as necessary to prevent IC malfunction due to noise.

Note 2: Connect GND to signal ground on the application circuit.

Note 3: Utmost care is required in the design of the output, VCC, and GND lines since the IC may shatter or explode due to short-circuits between outputs, short to VCC or short to ground. The IC may also shatter or explode when it is installed in a wrong orientation.

Package Dimensions

SSOP30-P-300-0.65

Unit : mm

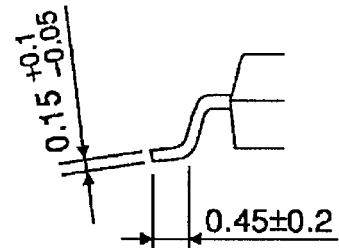
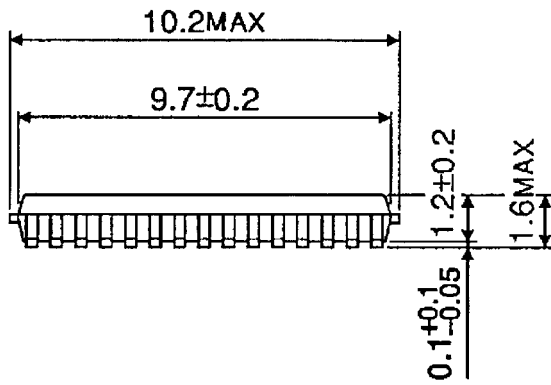
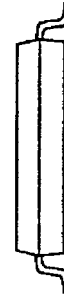
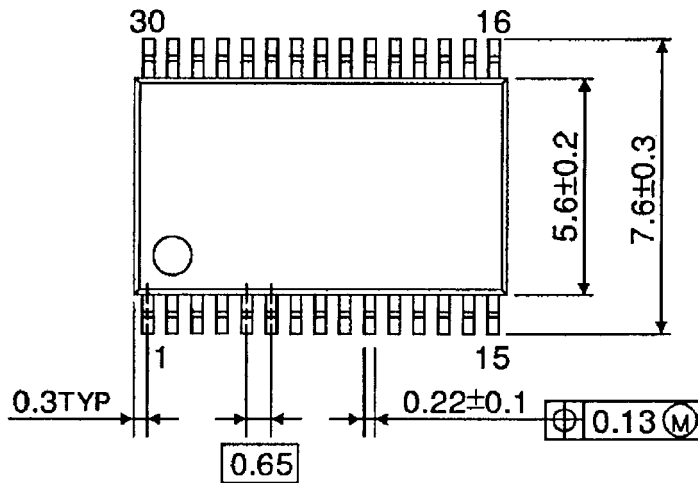

Weight: 0.17 g (typ.)

Notes on Contents

Block Diagrams

Some of the functional blocks, circuits, or constants in the block diagram may be omitted or simplified for explanatory purposes.

Equivalent Circuits

The equivalent circuit diagrams may be simplified or some parts of them may be omitted for explanatory purposes.

Timing Charts

Timing charts may be simplified for explanatory purposes.

Absolute Maximum ratings

The absolute maximum ratings of a semiconductor device are a set of ratings that must not be exceeded, even for a moment. Do not exceed any of these ratings. Exceeding the rating(s) may cause device breakdown, damage, deterioration or ignition, and may result injury by explosion or combustion.

Applications using the device should be designed so that no maximum rating will ever be exceeded under any operating conditions.

It must be ensured that the device is used within the specified operating range.

Application Circuits

The application circuits shown in this document are provided for reference purposes only. Thorough evaluation is required, especially at the mass production design stage.

Toshiba does not grant any license to any industrial property rights by providing these examples of application circuits.

Test Circuits

Components in the test circuits are used only to obtain and confirm the device characteristics. These components and circuits are not guaranteed to prevent malfunction or failure from occurring in the application equipment.

IC Usage Considerations

Notes on handling of ICs

- (1) The absolute maximum ratings of a semiconductor device are a set of ratings that must not be exceeded, even for a moment. Do not exceed any of these ratings.
Exceeding the rating(s) may cause the device breakdown, damage or deterioration, and may result injury by explosion or combustion.
- (2) Use an appropriate power supply fuse to ensure that a large current does not continuously flow in case of over current and/or IC failure. The IC will fully break down when used under conditions that exceed its absolute maximum ratings, when the wiring is routed improperly or when an abnormal pulse noise occurs from the wiring or load, causing a large current to continuously flow and the breakdown can lead smoke or ignition. To minimize the effects of the flow of a large current in case of breakdown, appropriate settings, such as fuse capacity, fusing time and insertion circuit location, are required.
- (3) If your design includes an inductive load such as a motor coil, incorporate a protection circuit into the design to prevent device malfunction or breakdown caused by the current resulting from the inrush current at power ON or the negative current resulting from the back electromotive force at power OFF. IC breakdown may cause injury, smoke or ignition.
Use a stable power supply with ICs with built-in protection functions. If the power supply is unstable, the protection function may not operate, causing IC breakdown. IC breakdown may cause injury, smoke or ignition.
- (4) Do not insert devices in the wrong orientation or incorrectly.
Make sure that the positive and negative terminals of power supplies are connected properly. Otherwise, the current or power consumption may exceed the absolute maximum rating, and exceeding the rating(s) may cause the device breakdown, damage or deterioration, and may result injury by explosion or combustion.
In addition, do not use any device that is applied the current with inserting in the wrong orientation or incorrectly even just one time.

Points to Remember on Handling of ICs

- (1) Over current protection circuit
Over current protection circuits (referred to as current limiter circuits) do not necessarily protect ICs under all circumstances. If the Over current protection circuits operate against the over current, clear the over current status immediately.
Depending on the method of use and usage conditions, such as exceeding absolute maximum ratings can cause the over current protection circuit to not operate properly or IC breakdown before operation. In addition, depending on the method of use and usage conditions, if over current continues to flow for a long time after operation, the IC may generate heat resulting in breakdown.
- (2) Heat radiation design
In using an IC with large current flow such as power amp, regulator or driver, please design the device so that heat is appropriately radiated, not to exceed the specified junction temperature (T_J) at any time and condition. These ICs generate heat even during normal use. An inadequate IC heat radiation design can lead to decrease in IC life, deterioration of IC characteristics or IC breakdown. In addition, please design the device taking into considerate the effect of IC heat radiation with peripheral components.
- (3) Back-EMF
When a motor rotates in the reverse direction, stops or slows down abruptly, a current flow back to the motor's power supply due to the effect of back-EMF. If the current sink capability of the power supply is small, the device's motor power supply and output pins might be exposed to conditions beyond absolute maximum ratings. To avoid this problem, take the effect of back-EMF into consideration in system design.

RESTRICTIONS ON PRODUCT USE

- Toshiba Corporation, and its subsidiaries and affiliates (collectively "TOSHIBA"), reserve the right to make changes to the information in this document, and related hardware, software and systems (collectively "Product") without notice.
- This document and any information herein may not be reproduced without prior written permission from TOSHIBA. Even with TOSHIBA's written permission, reproduction is permissible only if reproduction is without alteration/omission.
- Though TOSHIBA works continually to improve Product's quality and reliability, Product can malfunction or fail. Customers are responsible for complying with safety standards and for providing adequate designs and safeguards for their hardware, software and systems which minimize risk and avoid situations in which a malfunction or failure of Product could cause loss of human life, bodily injury or damage to property, including data loss or corruption. Before customers use the Product, create designs including the Product, or incorporate the Product into their own applications, customers must also refer to and comply with (a) the latest versions of all relevant TOSHIBA information, including without limitation, this document, the specifications, the data sheets and application notes for Product and the precautions and conditions set forth in the "TOSHIBA Semiconductor Reliability Handbook" and (b) the instructions for the application with which the Product will be used with or for. Customers are solely responsible for all aspects of their own product design or applications, including but not limited to (a) determining the appropriateness of the use of this Product in such design or applications; (b) evaluating and determining the applicability of any information contained in this document, or in charts, diagrams, programs, algorithms, sample application circuits, or any other referenced documents; and (c) validating all operating parameters for such designs and applications. **TOSHIBA ASSUMES NO LIABILITY FOR CUSTOMERS' PRODUCT DESIGN OR APPLICATIONS.**
- **PRODUCT IS NEITHER INTENDED NOR WARRANTED FOR USE IN EQUIPMENTS OR SYSTEMS THAT REQUIRE EXTRAORDINARILY HIGH LEVELS OF QUALITY AND/OR RELIABILITY, AND/OR A MALFUNCTION OR FAILURE OF WHICH MAY CAUSE LOSS OF HUMAN LIFE, BODILY INJURY, SERIOUS PROPERTY DAMAGE AND/OR SERIOUS PUBLIC IMPACT ("UNINTENDED USE").** Except for specific applications as expressly stated in this document, Unintended Use includes, without limitation, equipment used in nuclear facilities, equipment used in the aerospace industry, medical equipment, equipment used for automobiles, trains, ships and other transportation, traffic signaling equipment, equipment used to control combustions or explosions, safety devices, elevators and escalators, devices related to electric power, and equipment used in finance-related fields. **IF YOU USE PRODUCT FOR UNINTENDED USE, TOSHIBA ASSUMES NO LIABILITY FOR PRODUCT.** For details, please contact your TOSHIBA sales representative.
- Do not disassemble, analyze, reverse-engineer, alter, modify, translate or copy Product, whether in whole or in part.
- Product shall not be used for or incorporated into any products or systems whose manufacture, use, or sale is prohibited under any applicable laws or regulations.
- The information contained herein is presented only as guidance for Product use. No responsibility is assumed by TOSHIBA for any infringement of patents or any other intellectual property rights of third parties that may result from the use of Product. No license to any intellectual property right is granted by this document, whether express or implied, by estoppel or otherwise.
- **ABSENT A WRITTEN SIGNED AGREEMENT, EXCEPT AS PROVIDED IN THE RELEVANT TERMS AND CONDITIONS OF SALE FOR PRODUCT, AND TO THE MAXIMUM EXTENT ALLOWABLE BY LAW, TOSHIBA (1) ASSUMES NO LIABILITY WHATSOEVER, INCLUDING WITHOUT LIMITATION, INDIRECT, CONSEQUENTIAL, SPECIAL, OR INCIDENTAL DAMAGES OR LOSS, INCLUDING WITHOUT LIMITATION, LOSS OF PROFITS, LOSS OF OPPORTUNITIES, BUSINESS INTERRUPTION AND LOSS OF DATA, AND (2) DISCLAIMS ANY AND ALL EXPRESS OR IMPLIED WARRANTIES AND CONDITIONS RELATED TO SALE, USE OF PRODUCT, OR INFORMATION, INCLUDING WARRANTIES OR CONDITIONS OF MERCHANTABILITY, FITNESS FOR A PARTICULAR PURPOSE, ACCURACY OF INFORMATION, OR NONINFRINGEMENT.**
- Do not use or otherwise make available Product or related software or technology for any military purposes, including without limitation, for the design, development, use, stockpiling or manufacturing of nuclear, chemical, or biological weapons or missile technology products (mass destruction weapons). Product and related software and technology may be controlled under the applicable export laws and regulations including, without limitation, the Japanese Foreign Exchange and Foreign Trade Law and the U.S. Export Administration Regulations. Export and re-export of Product or related software or technology are strictly prohibited except in compliance with all applicable export laws and regulations.
- Please contact your TOSHIBA sales representative for details as to environmental matters such as the RoHS compatibility of Product. Please use Product in compliance with all applicable laws and regulations that regulate the inclusion or use of controlled substances, including without limitation, the EU RoHS Directive. **TOSHIBA ASSUMES NO LIABILITY FOR DAMAGES OR LOSSES OCCURRING AS A RESULT OF NONCOMPLIANCE WITH APPLICABLE LAWS AND REGULATIONS.**