

SN54LS595, SN54LS596, SN74LS595, SN74LS596 8-BIT SHIFT REGISTERS WITH OUTPUT LATCHES

SDLS006

D2634, JANUARY 1981 (REVISED MARCH 1988)

- 8-Bit Serial-In, Parallel-Out Shift Registers with Storage
- Choice of 3-State ('LS595) or Open-Collector ('LS596) Parallel Outputs
- Shift Register Has Direct Clear
- Accurate Shift Frequency: DC to 20 MHz

description

These devices each contain an 8-bit serial-in, parallel-out shift register that feeds an 8-bit D-type storage register. The storage register has parallel 3-state ('LS595) or open-collector ('LS596) outputs. Separate clocks are provided for both the shift register and the storage register. The shift register has a direct-overriding clear, serial input, and serial output pins for cascading.

Both the shift register and storage register clocks are positive-edge triggered. If the user wishes to connect both clocks together, the shift register state will always be one clock pulse ahead of the storage register.

SN54LS595, SN54LS596 . . . J OR W PACKAGE
SN74LS595, SN74LS596 . . . N PACKAGE
(TOP VIEW)

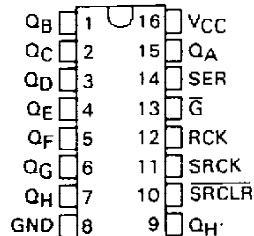

SN54LS595, SN54LS596 . . . FK PACKAGE
(TOP VIEW)

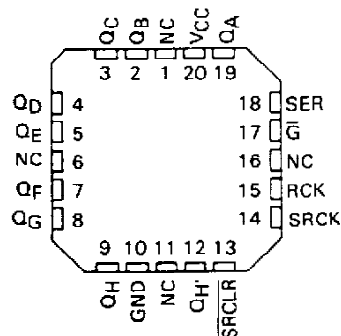

NC - No internal connection

schematics of inputs and outputs

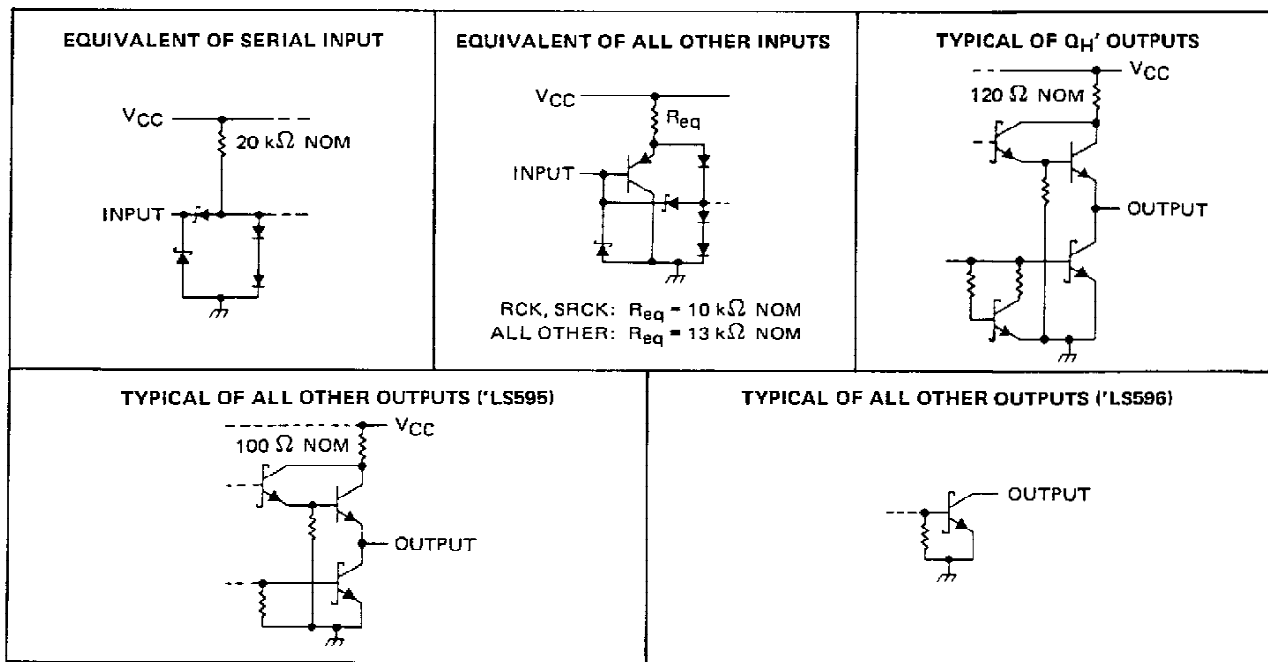

PRODUCTION DATA documents contain information current as of publication date. Products conform to specifications per the terms of Texas Instruments standard warranty. Production processing does not necessarily include testing of all parameters.

TEXAS
INSTRUMENTS

POST OFFICE BOX 655012 • DALLAS, TEXAS 75265

SN54LS595, SN54LS596, SN74LS595, SN74LS596
8-BIT SHIFT REGISTERS WITH OUTPUT LATCHES

logic diagram (positive logic)

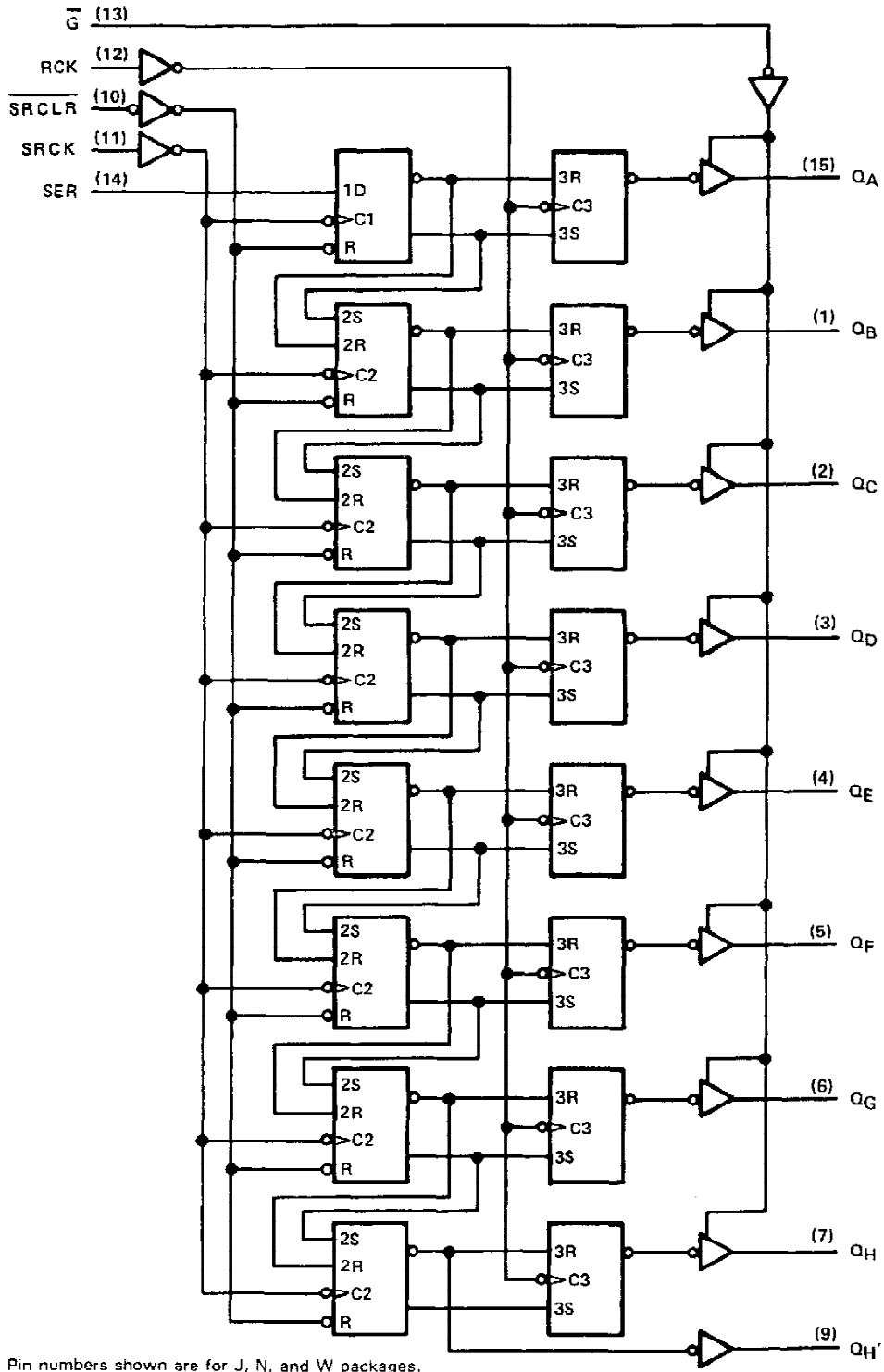

Pin numbers shown are for J, N, and W packages.

TEXAS
INSTRUMENTS

POST OFFICE BOX 655012 • DALLAS, TEXAS 75265

SN54LS595, SN54LS596, SN74LS595, SN74LS596 8-BIT SHIFT REGISTERS WITH OUTPUT LATCHES

logic symbols †

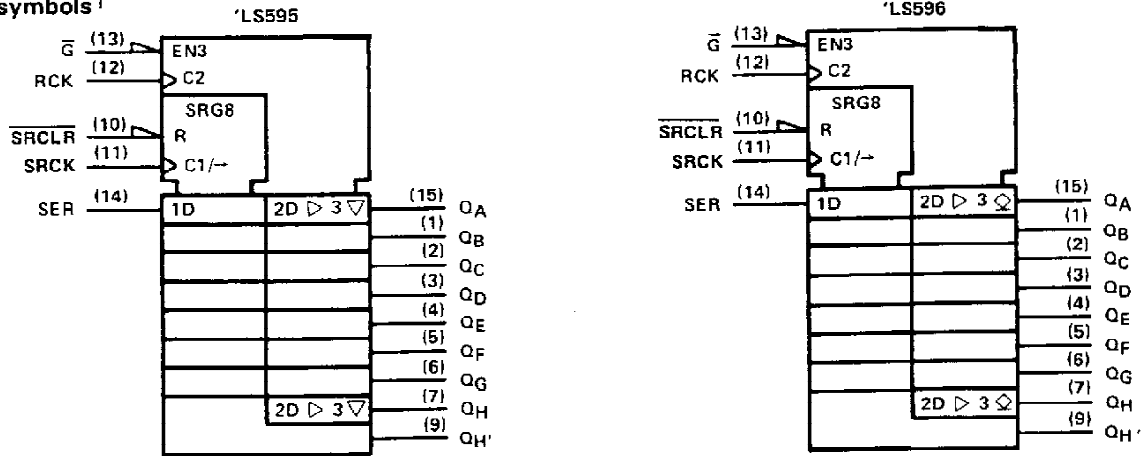

†These symbols are in accordance with ANSI/IEEE Std. 91-1984 and IEC Publication 617-12. Pin numbers shown are for J, N, and W packages.

absolute maximum ratings over operating free-air temperature range (unless otherwise noted)

Supply voltage, V_{CC} (see Note 1)	7 V
Input voltage	7 V
Off-state output voltage	5.5 V
Operating free-air temperature range: SN54LS595, SN54LS596	-55°C to 125°C
SN74LS595, SN74LS596	0°C to 70°C
Storage temperature range	-65°C to 150°C

NOTE 1: Voltage values are with respect to the network ground terminal.

recommended operating conditions

	SN54LS'			SN74LS'			UNIT
	MIN	NOM	MAX	MIN	NOM	MAX	
V_{CC} Supply voltage	4.5	5	5.5	4.75	5	5.25	V
V_{IH} High-level input voltage	2			2			V
V_{IL} Low-level input voltage			0.7			0.8	V
V_{OH} High-level output voltage			5.5			5.5	V
I_{OH} High-level output current	QA thru QH, 'LS596 only						mA
	QH'		-1			-1	
I_{OL} Low-level output current	QA thru QH, 'LS595 only					-2.6	mA
	QH'		8			16	
	Q		12			24	
f_{SRCK} Shift clock frequency	0		20	0		20	MHz
$t_w(SRCK)$ Duration of shift clock pulse	25			25			ns
$t_w(RCK)$ Duration of register clock pulse	20			20			ns
$t_w(SRCLR)$ Duration of shift clear pulse, low level	20			20			ns
t_{su} Setup time	SRCLR inactive before SRCK †		20			20	ns
	SER before SRCK †		20			20	
	SRCK † before RCK † (see Note 2)		40			40	
	SRCLR low before RCK †		40			40	
t_h Hold time	SER after SRCK †		0			0	ns
T_A Operating free-air temperature	-55		125	0		70	°C

NOTE 2: This setup time ensures the register will see stable data from the shift-register outputs. The clocks may be connected together, in which case the storage register state will be one clock pulse behind the shift register.



POST OFFICE BOX 655012 • DALLAS, TEXAS 75265

SN54LS595, SN54LS596, SN74LS595, SN74LS596
8-BIT SHIFT REGISTERS WITH OUTPUT LATCHES

electrical characteristics over recommended operating free-air temperature range (unless otherwise noted)

PARAMETER	TEST CONDITIONS †	SN54LS*		SN74LS*		UNIT		
		MIN	TYP ‡	MAX	MIN		TYP ‡	MAX
V _{IK}	V _{CC} = MIN, I _I = -18 mA			-1.5		-1.5	V	
V _{OH}	'LS595 Q Q _H '	V _{CC} = MIN, V _{IH} = 2 V, V _{IL} = MAX	I _{OH} = -1 mA	2.4	3.2			
			I _{OH} = -2.6 mA			2.4	3.1	
			I _{OH} = -1 mA	2.4	3.2	2.4	3.2	
I _{OH}	'LS596 Q	V _{CC} = MIN, V _{IH} = 2 V, V _{IL} = MAX, V _{OH} = 5.5 V					0.1	mA
V _{OL}	Q	V _{CC} = MIN, V _{IH} = 2 V, V _{IL} = MAX	I _{OL} = 12 mA	0.25	0.4	0.25	0.4	
			I _{OL} = 24 mA			0.35	0.5	
			I _{OL} = 8 mA	0.25	0.4	0.25	0.4	
			I _{OL} = 16 mA			0.35	0.5	
I _{OZH}	'LS595 Q	V _{CC} = MAX, V _{IH} = 2 V, V _{IL} = MAX, V _{OH} = 2.7 V			20		20	μA
I _{OZL}	'LS595 Q	V _{CC} = MAX, V _{IH} = 2 V, V _{IL} = MAX, V _{OH} = 0.4 V			-20		-20	μA
I _I		V _{CC} = MAX, V _I = 7 V			0.1		0.1	mA
I _{IH}		V _{CC} = MAX, V _I = 2.7 V			20		20	μA
I _{IL}	SER	V _{CC} = MAX, V _I = 0.4 V			-0.4		-0.4	
	All others				-0.2		-0.2	
I _{OS} §	'LS595 Q	V _{CC} = MAX, V _O = 0 V			-30		-130	
	Q _H '				-20		-100	
I _{CCH}	'LS595	V _{CC} = MAX,			33		50	
	'LS596				30		45	
I _{CCL}	'LS595	All possible inputs grounded, All outputs open			42		65	
	'LS596				36		55	
I _{CCZ}	'LS595			44		65		

† For conditions shown as MIN or MAX, use the appropriate value specified under recommended operating conditions.

‡ All typical values are at V_{CC} = 5 V, T_A = 25°C.

§ Not more than one output should be shorted at a time, and duration of the short-circuit should not exceed one second.

TEXAS
 INSTRUMENTS

POST OFFICE BOX 655012 • DALLAS, TEXAS 75265

SN54LS595, SN54LS596, SN74LS595, SN74LS596
8-BIT SHIFT REGISTERS WITH OUTPUT LATCHES

switching characteristics, $V_{CC} = 5\text{ V}$, $T_A = 25^\circ\text{C}$ (see note 3)

PARAMETER	FROM (INPUT)	TO (OUTPUT)	TEST CONDITIONS	'LS595			'LS596			UNIT
				MIN	TYP	MAX	MIN	TYP	MAX	
t_{PLH}	SRCK ↑	Q_H'	$R_L = 1\text{ k}\Omega$, $C_L = 30\text{ pF}$	12	18		14	21	ns	
t_{PHL}				17	25		20	30	ns	
t_{PLH}	RCK ↑	Q_A thru Q_H	$R_L = 667\ \Omega$, $C_L = 45\text{ pF}$	12	18		28	42	ns	
t_{PHL}				24	35		24	35	ns	
t_{PZH}	\overline{G} ↓	Q_A thru Q_H		20	30				ns	
t_{PZL}				25	38				ns	
t_{PHZ}	\overline{G} ↑	Q_A thru Q_H	$R_L = 667\ \Omega$, $C_L = 5\text{ pF}$	20	30				ns	
t_{PLZ}				25	38				ns	
t_{PLH}	\overline{G} ↑	Q_A thru Q_H	$R_L = 667\ \Omega$, $C_L = 45\text{ pF}$				40	60	ns	
t_{PHL}	\overline{G} ↓	Q_A thru Q_H					25	38	ns	
t_{PHL}	SRCLR ↓	Q_H'	$R_L = 1\text{ k}\Omega$, $C_L = 30\text{ pF}$	24	35		24	35	ns	



NOTE 3: Load circuits and voltage waveforms are shown in Section 1.

TEXAS
INSTRUMENTS

POST OFFICE BOX 655012 • DALLAS, TEXAS 75265

PACKAGING INFORMATION

Orderable Device	Status (1)	Package Type	Package Drawing	Pins	Package Qty	Eco Plan (2)	Lead/Ball Finish (6)	MSL Peak Temp (3)	Op Temp (°C)	Device Marking (4/5)	Samples
5962-8671701EA	ACTIVE	CDIP	J	16	1	TBD	Call TI	N / A for Pkg Type	-55 to 125	5962-8671701EA SNJ54LS595J	Samples
5962-8671701FA	ACTIVE	CFP	W	16	1	TBD	Call TI	N / A for Pkg Type	-55 to 125	5962-8671701FA SNJ54LS595W	Samples
5962-8671701FA	ACTIVE	CFP	W	16	1	TBD	Call TI	N / A for Pkg Type	-55 to 125	5962-8671701FA SNJ54LS595W	Samples
SN54LS595J	ACTIVE	CDIP	J	16	1	TBD	Call TI	N / A for Pkg Type	-55 to 125	SN54LS595J	Samples
SN54LS595J	ACTIVE	CDIP	J	16	1	TBD	Call TI	N / A for Pkg Type	-55 to 125	SN54LS595J	Samples
SN74LS595D	ACTIVE	SOIC	D	16	40	Green (RoHS & no Sb/Br)	NIPDAU	Level-1-260C-UNLIM	0 to 70	LS595	Samples
SN74LS595D	ACTIVE	SOIC	D	16	40	Green (RoHS & no Sb/Br)	NIPDAU	Level-1-260C-UNLIM	0 to 70	LS595	Samples
SN74LS595DG4	ACTIVE	SOIC	D	16	40	Green (RoHS & no Sb/Br)	NIPDAU	Level-1-260C-UNLIM	0 to 70	LS595	Samples
SN74LS595DG4	ACTIVE	SOIC	D	16	40	Green (RoHS & no Sb/Br)	NIPDAU	Level-1-260C-UNLIM	0 to 70	LS595	Samples
SN74LS595DR	ACTIVE	SOIC	D	16	2500	Green (RoHS & no Sb/Br)	NIPDAU	Level-1-260C-UNLIM	0 to 70	LS595	Samples
SN74LS595DR	ACTIVE	SOIC	D	16	2500	Green (RoHS & no Sb/Br)	NIPDAU	Level-1-260C-UNLIM	0 to 70	LS595	Samples
SN74LS595N	ACTIVE	PDIP	N	16	25	Green (RoHS & no Sb/Br)	NIPDAU	N / A for Pkg Type	0 to 70	SN74LS595N	Samples
SN74LS595N	ACTIVE	PDIP	N	16	25	Green (RoHS & no Sb/Br)	NIPDAU	N / A for Pkg Type	0 to 70	SN74LS595N	Samples
SN74LS596N	ACTIVE	PDIP	N	16	25	Green (RoHS & no Sb/Br)	NIPDAU	N / A for Pkg Type	0 to 70	SN74LS596N	Samples
SN74LS596N	ACTIVE	PDIP	N	16	25	Green (RoHS & no Sb/Br)	NIPDAU	N / A for Pkg Type	0 to 70	SN74LS596N	Samples
SNJ54LS595J	ACTIVE	CDIP	J	16	1	TBD	Call TI	N / A for Pkg Type	-55 to 125	5962-8671701EA SNJ54LS595J	Samples
SNJ54LS595J	ACTIVE	CDIP	J	16	1	TBD	Call TI	N / A for Pkg Type	-55 to 125	5962-8671701EA SNJ54LS595J	Samples

Orderable Device	Status (1)	Package Type	Package Drawing	Pins	Package Qty	Eco Plan (2)	Lead/Ball Finish (6)	MSL Peak Temp (3)	Op Temp (°C)	Device Marking (4/5)	Samples
SNJ54LS595W	ACTIVE	CFP	W	16	1	TBD	Call TI	N / A for Pkg Type	-55 to 125	5962-8671701FA SNJ54LS595W	
SNJ54LS595W	ACTIVE	CFP	W	16	1	TBD	Call TI	N / A for Pkg Type	-55 to 125	5962-8671701FA SNJ54LS595W	

(1) The marketing status values are defined as follows:

ACTIVE: Product device recommended for new designs.

LIFEBUY: TI has announced that the device will be discontinued, and a lifetime-buy period is in effect.

NRND: Not recommended for new designs. Device is in production to support existing customers, but TI does not recommend using this part in a new design.

PREVIEW: Device has been announced but is not in production. Samples may or may not be available.

OBSOLETE: TI has discontinued the production of the device.

(2) **RoHS:** TI defines "RoHS" to mean semiconductor products that are compliant with the current EU RoHS requirements for all 10 RoHS substances, including the requirement that RoHS substance do not exceed 0.1% by weight in homogeneous materials. Where designed to be soldered at high temperatures, "RoHS" products are suitable for use in specified lead-free processes. TI may reference these types of products as "Pb-Free".

RoHS Exempt: TI defines "RoHS Exempt" to mean products that contain lead but are compliant with EU RoHS pursuant to a specific EU RoHS exemption.

Green: TI defines "Green" to mean the content of Chlorine (Cl) and Bromine (Br) based flame retardants meet JS709B low halogen requirements of <=1000ppm threshold. Antimony trioxide based flame retardants must also meet the <=1000ppm threshold requirement.

(3) MSL, Peak Temp. - The Moisture Sensitivity Level rating according to the JEDEC industry standard classifications, and peak solder temperature.

(4) There may be additional marking, which relates to the logo, the lot trace code information, or the environmental category on the device.

(5) Multiple Device Markings will be inside parentheses. Only one Device Marking contained in parentheses and separated by a "~" will appear on a device. If a line is indented then it is a continuation of the previous line and the two combined represent the entire Device Marking for that device.

(6) Lead/Ball Finish - Orderable Devices may have multiple material finish options. Finish options are separated by a vertical ruled line. Lead/Ball Finish values may wrap to two lines if the finish value exceeds the maximum column width.

Important Information and Disclaimer:The information provided on this page represents TI's knowledge and belief as of the date that it is provided. TI bases its knowledge and belief on information provided by third parties, and makes no representation or warranty as to the accuracy of such information. Efforts are underway to better integrate information from third parties. TI has taken and continues to take reasonable steps to provide representative and accurate information but may not have conducted destructive testing or chemical analysis on incoming materials and chemicals. TI and TI suppliers consider certain information to be proprietary, and thus CAS numbers and other limited information may not be available for release.

In no event shall TI's liability arising out of such information exceed the total purchase price of the TI part(s) at issue in this document sold by TI to Customer on an annual basis.

OTHER QUALIFIED VERSIONS OF SN54LS595, SN74LS595 :

- Catalog: [SN74LS595](#)
- Military: [SN54LS595](#)

NOTE: Qualified Version Definitions:

- Catalog - TI's standard catalog product
- Military - QML certified for Military and Defense Applications

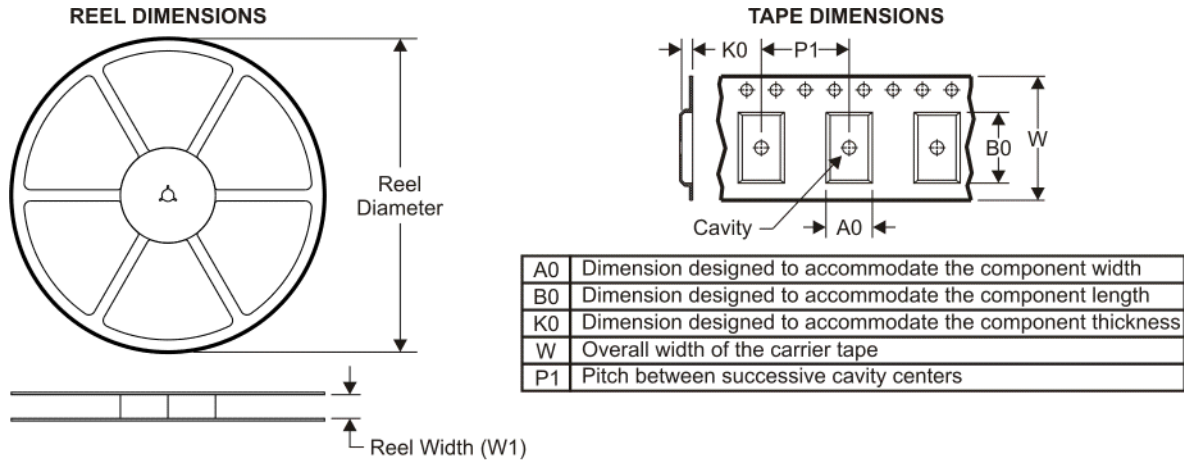
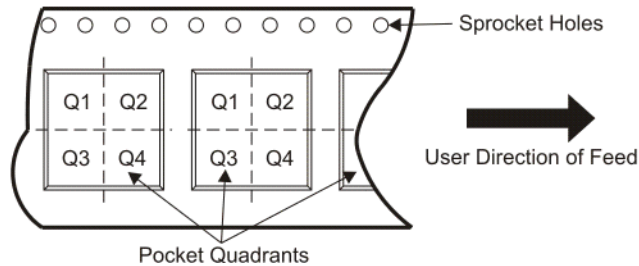
TAPE AND REEL INFORMATION

QUADRANT ASSIGNMENTS FOR PIN 1 ORIENTATION IN TAPE

*All dimensions are nominal

Device	Package Type	Package Drawing	Pins	SPQ	Reel Diameter (mm)	Reel Width W1 (mm)	A0 (mm)	B0 (mm)	K0 (mm)	P1 (mm)	W (mm)	Pin1 Quadrant
SN74LS595DR	SOIC	D	16	2500	330.0	16.4	6.5	10.3	2.1	8.0	16.0	Q1

TAPE AND REEL BOX DIMENSIONS



*All dimensions are nominal



Device	Package Type	Package Drawing	Pins	SPQ	Length (mm)	Width (mm)	Height (mm)
SN74LS595DR	SOIC	D	16	2500	333.2	345.9	28.6

D (R-PDSO-G16)

PLASTIC SMALL OUTLINE



4040047-6/M 06/11

- NOTES:
- A. All linear dimensions are in inches (millimeters).
 - B. This drawing is subject to change without notice.
 -  C. Body length does not include mold flash, protrusions, or gate burrs. Mold flash, protrusions, or gate burrs shall not exceed 0.006 (0,15) each side.
 -  D. Body width does not include interlead flash. Interlead flash shall not exceed 0.017 (0,43) each side.
 - E. Reference JEDEC MS-012 variation AC.

D (R-PDSO-G16)

PLASTIC SMALL OUTLINE

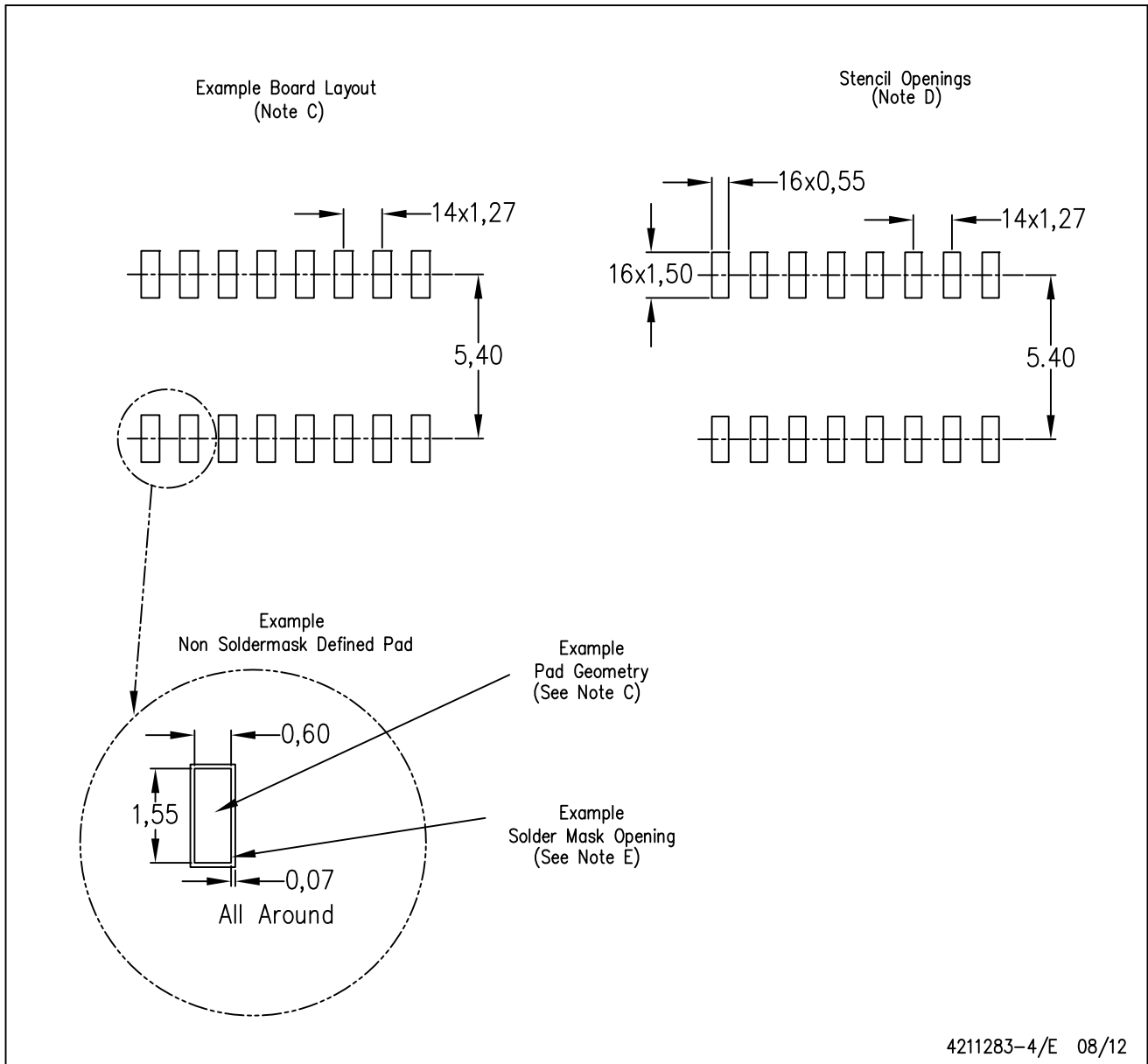

- NOTES:
- All linear dimensions are in millimeters.
 - This drawing is subject to change without notice.
 - Publication IPC-7351 is recommended for alternate designs.
 - Laser cutting apertures with trapezoidal walls and also rounding corners will offer better paste release. Customers should contact their board assembly site for stencil design recommendations. Refer to IPC-7525 for other stencil recommendations.
 - Customers should contact their board fabrication site for solder mask tolerances between and around signal pads.

W (R-GDFP-F16)

CERAMIC DUAL FLATPACK

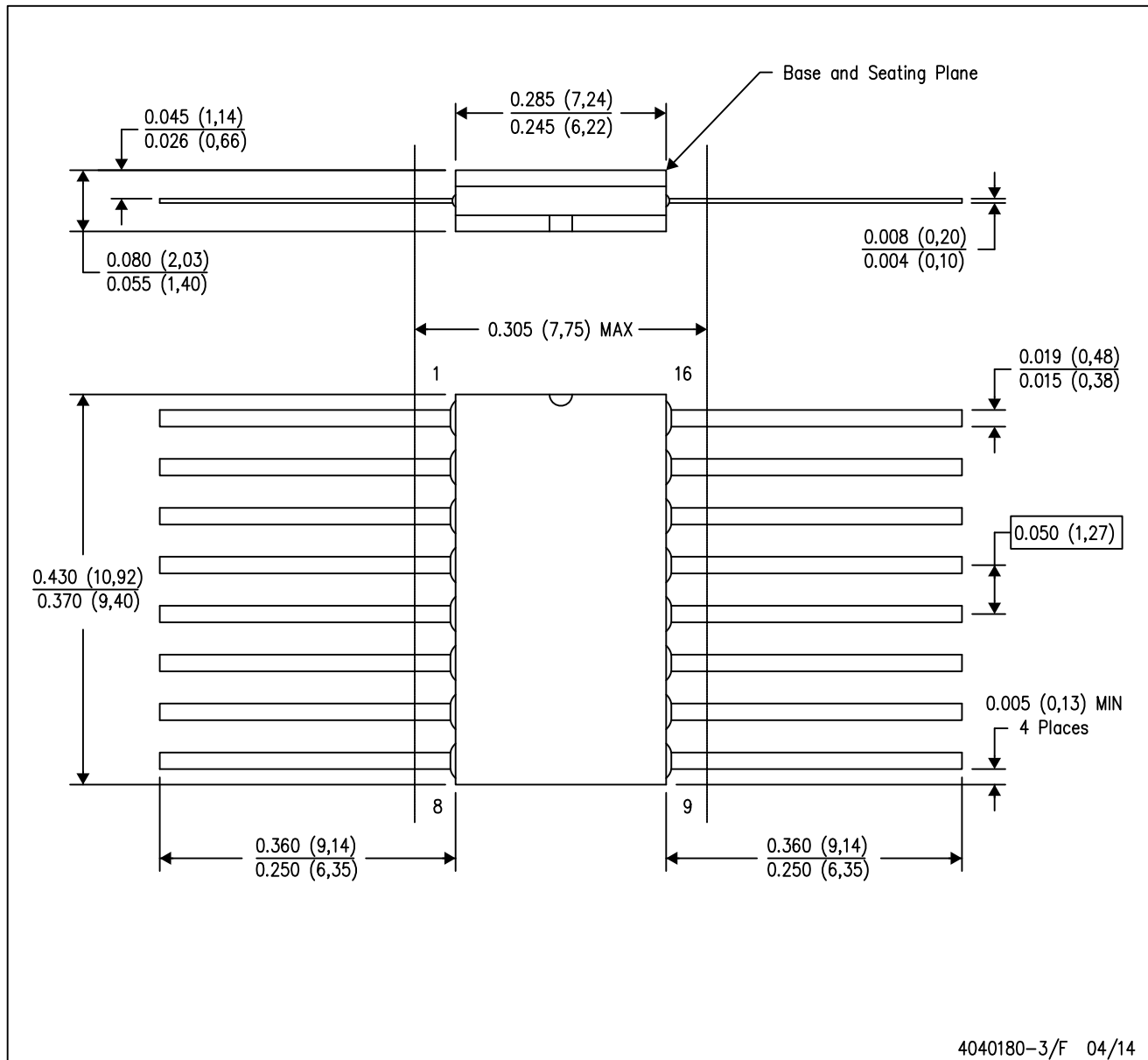

- NOTES:
- A. All linear dimensions are in inches (millimeters).
 - B. This drawing is subject to change without notice.
 - C. This package can be hermetically sealed with a ceramic lid using glass frit.
 - D. Index point is provided on cap for terminal identification only.
 - E. Falls within MIL STD 1835 GDFP2-F16

J (R-GDIP-T**)

14 LEADS SHOWN

CERAMIC DUAL IN-LINE PACKAGE



DIM \ PINS **	14	16	18	20
A	0.300 (7,62) BSC	0.300 (7,62) BSC	0.300 (7,62) BSC	0.300 (7,62) BSC
B MAX	0.785 (19,94)	.840 (21,34)	0.960 (24,38)	1.060 (26,92)
B MIN	—	—	—	—
C MAX	0.300 (7,62)	0.300 (7,62)	0.310 (7,87)	0.300 (7,62)
C MIN	0.245 (6,22)	0.245 (6,22)	0.220 (5,59)	0.245 (6,22)



4040083/F 03/03

- NOTES:
- A. All linear dimensions are in inches (millimeters).
 - B. This drawing is subject to change without notice.
 - C. This package is hermetically sealed with a ceramic lid using glass frit.
 - D. Index point is provided on cap for terminal identification only on press ceramic glass frit seal only.
 - E. Falls within MIL STD 1835 GDIP1-T14, GDIP1-T16, GDIP1-T18 and GDIP1-T20.

N (R-PDIP-T**)

PLASTIC DUAL-IN-LINE PACKAGE

16 PINS SHOWN



- NOTES:
- A. All linear dimensions are in inches (millimeters).
 - B. This drawing is subject to change without notice.
 - (C) Falls within JEDEC MS-001, except 18 and 20 pin minimum body length (Dim A).
 - (D) The 20 pin end lead shoulder width is a vendor option, either half or full width.

4040049/E 12/2002

IMPORTANT NOTICE AND DISCLAIMER

TI PROVIDES TECHNICAL AND RELIABILITY DATA (INCLUDING DATASHEETS), DESIGN RESOURCES (INCLUDING REFERENCE DESIGNS), APPLICATION OR OTHER DESIGN ADVICE, WEB TOOLS, SAFETY INFORMATION, AND OTHER RESOURCES "AS IS" AND WITH ALL FAULTS, AND DISCLAIMS ALL WARRANTIES, EXPRESS AND IMPLIED, INCLUDING WITHOUT LIMITATION ANY IMPLIED WARRANTIES OF MERCHANTABILITY, FITNESS FOR A PARTICULAR PURPOSE OR NON-INFRINGEMENT OF THIRD PARTY INTELLECTUAL PROPERTY RIGHTS.

These resources are intended for skilled developers designing with TI products. You are solely responsible for (1) selecting the appropriate TI products for your application, (2) designing, validating and testing your application, and (3) ensuring your application meets applicable standards, and any other safety, security, or other requirements. These resources are subject to change without notice. TI grants you permission to use these resources only for development of an application that uses the TI products described in the resource. Other reproduction and display of these resources is prohibited. No license is granted to any other TI intellectual property right or to any third party intellectual property right. TI disclaims responsibility for, and you will fully indemnify TI and its representatives against, any claims, damages, costs, losses, and liabilities arising out of your use of these resources.

TI's products are provided subject to TI's Terms of Sale (www.ti.com/legal/termsofsale.html) or other applicable terms available either on ti.com or provided in conjunction with such TI products. TI's provision of these resources does not expand or otherwise alter TI's applicable warranties or warranty disclaimers for TI products.

Mailing Address: Texas Instruments, Post Office Box 655303, Dallas, Texas 75265
Copyright © 2020, Texas Instruments Incorporated