

Noted for its circuit flexibility, the 305 also provides the highest accuracy among analog timers. Available for either ON-Delay or OFF-Delay operation.

The 305 provides delay, interval or pulse timing function for up to 7 load circuits through two instantaneous and two delayed switches. It features a plug-in design and cycle progress indication.

HIGHEST ACCURACY: Because of its exclusive infinite engagement clutch, the 305 has a repeat accuracy of 0.2%, highest of any timer in its class.

PLUG-IN AND DUST-TIGHT DESIGN: By virtue of its true plug-in design, the body of a 305 can be replaced in seconds without disturbing the housing or disconnecting the wiring. Its gasketed dial assembly forms a dust-tight seal against the housing, whether panel or surface-mounted.

FASTEST RESET: All 305 timers reset to a full-scale setting within 0.1 second, proportionately faster for shorter settings.

CIRCUIT FLEXIBILITY: All the contacts of its two instantaneous and two delayed load switches are externally accessible at a 14 point terminal block.

LONGEST LIFE: With an average mechanical life expectancy of over 5,000,000 operations before the first failure, the 305 is the leader in its class.

PILOT LIGHT: A built-in pilot light indicates that the timer is running.

OPERATION

The 305 is a synchronous motor-driven timer with an electrically-operated clutch equipped either for ON-Delay or OFF-Delay operation.

ON-DELAY: When power is applied (start signal on), the clutch solenoid is energized. Two things happen immediately and simultaneously, the instantaneous switches transfer from one set of contacts to the other, and the motor begins to drive the cycle progress pointer toward zero.

At the end of the timed period, the pointer trips one of the delayed switches, a brief time later (about 1/2% of full scale), the other delayed switch is tripped, stopping the timer motor but leaving the clutch engaged. The timer does not reset until power to the clutch is removed.

OFF-DELAY: Timing starts when power is removed (start signal off), from the spring-loaded, normally engaged clutch. The timer is reset when power is restored to the clutch solenoid; simultaneously, the instantaneous contacts are tripped. Action of the delayed contacts is the same as with ON-Delay timers. A power outage stops the motor but does not reset the OFF-Delay 305E.



Motor-Driven Analog Reset Timer

SWITCH	CONTACTS	ON DELAY			
		Timing Sequence**			
		Before Start	During Cycle *	*	End of Cycle *
Instantaneous	14-9/6-8	Black	Gray	Black	Gray
	14-10/6-7	Gray	Black	Gray	Black
Delayed (D ₂)	11-12	Black	Black	Black	Gray
	11-13	Gray	Gray	Gray	Black
Delayed (D ₁)	4-5	Black	Black	Black	Gray
	4-3	Gray	Gray	Gray	Black

* D₂ trips approximately 1/2% of range after end of cycle.
** Assumes a sustained closed start signal (i.e. longer than the dial set time).

SWITCH	CONTACTS	OFF DELAY			
		Timing Sequence**			
		Before Start	During Cycle *	*	End of Cycle *
Instantaneous	14-9/6-8	Black	Gray	Black	Gray
	14-10/6-7	Gray	Black	Gray	Black
Delayed (D ₂)	11-12	Black	Black	Black	Gray
	11-13	Gray	Gray	Gray	Black
Delayed (D ₁)	4-5	Black	Black	Black	Gray
	4-3	Gray	Gray	Gray	Black

* D₂ trips approximately 1/2% to 5% of range after end of cycle.
** Assumes a sustained closed start signal (i.e. longer than the dial set time).

BLACK
 Circuit Closed

GRAY
 Circuit Open

DIMENSIONS (INCHES/MILLIMETERS)

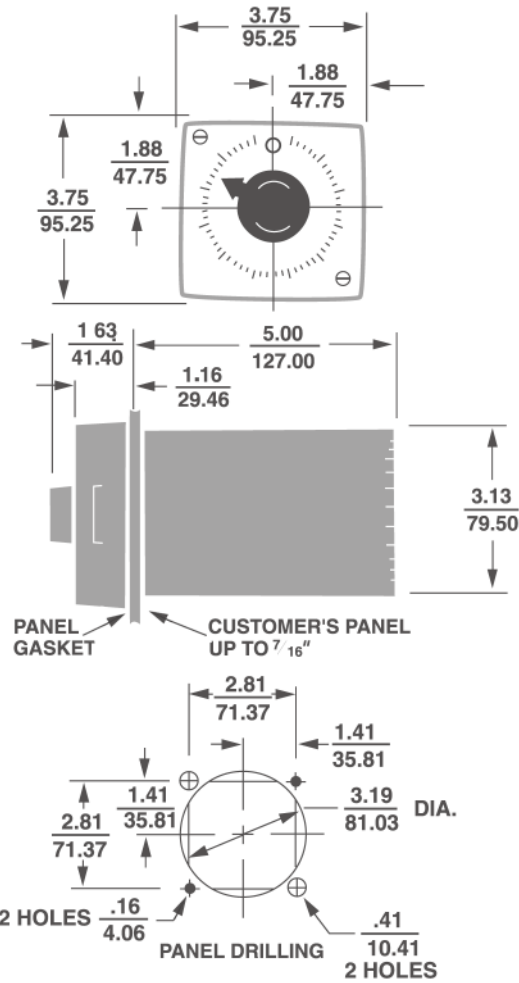

WIRING

AC WIRING

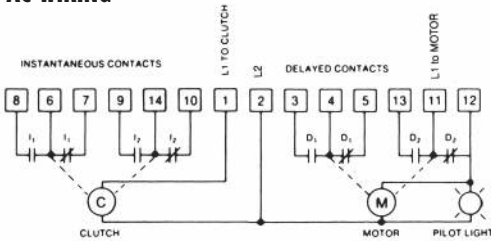

TERMINAL WIRING

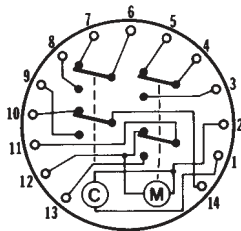

SPECIFICATIONS

MODELS	ON-Delay OFF-Delay
RANGES (AC)	13 standard ranges, from 6 SEC to 60 HRS at 60 Hz.
REPEAT ACCURACY	AC MODELS: - 0.2% of full scale (For ranges of 60 SEC or less, it may be necessary to run timer motor before start to achieve related accuracy)
RESET TIME	0.1 SEC, full scale
MIN. SETTING	1/60th of range (all models except 0.3 SEC for 6 SEC model)
DIAL DIVISIONS	6 SEC, 60 SEC, 120 SEC, 240 SEC, 60 MIN, 240 MIN, 6 HR, and 60 HR =120 Dial Divisions 30 SEC, 15 MIN, 30 MIN, 15 HR., and 30 HR =150 Dial Divisions
LIFE EXPECTANCY	MECHANICAL: over 5,000,000 operations CONTACTS: 3,000,000 operations under resistive or inductive load of 1A
TIMING MOTOR	Synchronous, permanently lubricated
TIMING	Single cycle interval or delay
LOAD SWITCHES	INSTANTANEOUS: two, each SPDT; self cleaning, heavy-duty silver contacts. DELAYED: two, each SPDT; precision type, silver contacts
CONTACT RATING (non-inductive):	10 amps, 120 VAC 5 amps, 240 VAC
PILOT LIGHT	Wired in parallel with motor.
TERMINALS	14 screw terminals accessible at rear; integral wiring diagram on timer housing.
HOUSING	Plug-in design; completely gasketed, dust-tight when surface or panel-mounted
POWER REQUIREMENTS	AC MODELS: 120, 60Hz (all ranges), (- 10%, - 10%) AC MODELS: running current 0.128 A (115 VAC) inrush current 0.628 A (115 VAC)
TEMPERATURE RATING	32° to 140°F (0° to 60°C)
WEIGHT	NET: 2 lb., 6 oz. SHIPPING: 2 lb., 12 oz.
MOUNTING ACCESSORIES	STANDARD: Hardware is provided to mount timer so that it is dust-tight from front of panel. OPTIONAL: Surface mounting with rear-facing terminals. (See Accessories)

RANGE-60 CYCLES 120 VAC

6 SEC	101
30 SEC	006
60 SEC	007
120 SEC	008
240 SEC	011
15 MIN	015
30 MIN	016
60 MIN	017
240 MIN	019
6 HR	030
15 HR	021
30 HR	022

**VOLTAGE
FREQUENCY**

120/60 A

MODEL NUMBER

MODEL NUMBER	305E				0		
RANGE							
VOLTAGE & FREQUENCY							
ARRANGEMENTS							
ON-DELAY (reset on power interruption)					1		
OFF-DELAY (non-reset on power interruption)					2		
Special					0		
SETTING							
Knob					0		
FEATURES							
Basic plug-in timer						P	
Standard Timer						X	
Basic standard unit							X
Special							K

ACCESSORIES:

Surface mounting bracket rear facing terminals 0305-263-64-00

TYPICAL INSTALLATIONS

- ⊙ CLUTCH SOLENOID
- ⊙ MOTOR
- ⊙ INDEPENDENT LOADS
- DEPENDENT LOADS
- ⊙ MOMENTARY STARTING CONTACT
- ⊙ SUSTAINED STARTING CONTACT
- ⊙ LOAD ENERGIZED
- ⊙ LOAD DE-ENERGIZED

- ⊙ DELAYED CONTACTS**
 Switch 4-5-3 transfers at dial "0."
 Switch 11-12-13 transfers 1% later.

All timers shown in "before start" position. Diagrams shown with power off unless otherwise marked.
 Maximum load current through any load carrying contact is 10 amperes.

ON-DELAY - Reset on power failure.

OFF-DELAY - Non-reset on power failure.

- ⊙ INSTANTANEOUS CONTACTS**
 Contacts are transferred when clutch is energized; transferred back, as shown when de-energized.

SUSTAINED START (ON DELAY)

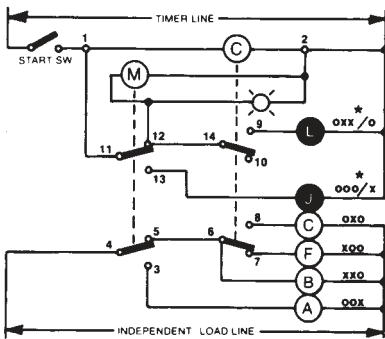

MOMENTARY START (ON DELAY)

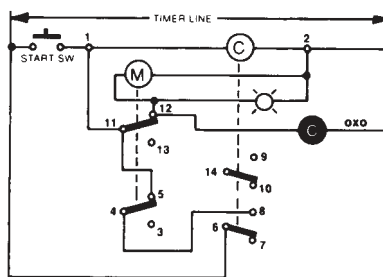

OFF DELAY

