

AUX.VIEW  
SCALE:2X

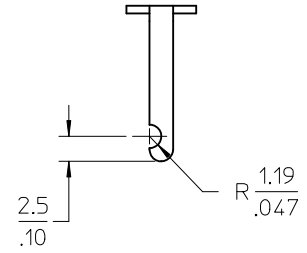
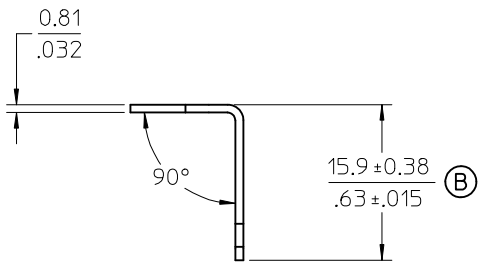

- NOTES:  
 1. MATERIAL: SEE TABLE  
 2. FINISHES: SEE TABLE  
 (B) 3. PART IS ROHS COMPLIANT.

CHANGE DIM/ADD NOTES EC NO: ETC2007-0438 DRWN: CLYORK 2007/07/12 CHKD: JMACNEIL 2007/07/12 APPR: JMACNEIL 2007/07/13	QUALITY SYMBOLS ▽ = 0 ∇ = 0	GENERAL TOLERANCES (UNLESS SPECIFIED)		SCALE 2:1	DESIGN UNITS INCH	THIRD ANGLE PROJECTION	REVISE ON CAD ONLY		
				DIMENSION STYLE MM/IN		TITLE TERMINAL, SOLDER, Y SHORT, CAT. # 143			
		4 PLACES ± --- ± ---		DRAWN BY R.STONE		DATE 08-18-03		MATERIAL NO. 380020159	
		3 PLACES ± --- ± .005		CHECKED BY RK		DATE 2-5-04			
2 PLACES ± 0.13 ± .01		APPROVED BY GHR		DATE 2-26-04		DOCUMENT NO. SD-38002-005			
1 PLACE ± 0.3 ± ---		DRAFT WHERE APPLICABLE MUST REMAIN WITHIN DIMENSIONS				SHEET NO. 1 OF 1			
ANGULAR ± 1/2°		THIS DRAWING CONTAINS INFORMATION THAT IS PROPRIETARY TO MOLEX INCORPORATED AND SHOULD NOT BE USED WITHOUT WRITTEN PERMISSION							

1	1	TERMINAL	BRASS	TIN PLATED
ITEM	QTY.	DESCRIPTION	MATERIAL	FINISH

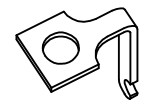
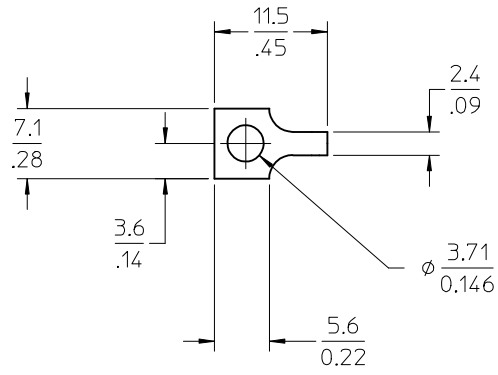

AUX.VIEW  
SCALE:2X

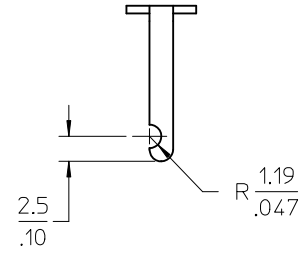
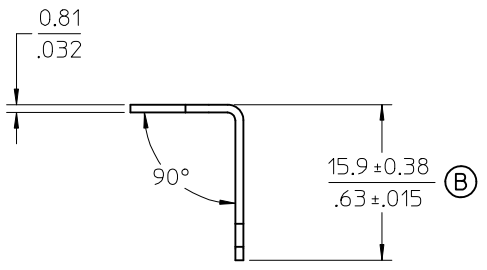

- NOTES:  
 1. MATERIAL: SEE TABLE  
 2. FINISHES: SEE TABLE  
 ③ 3. PART IS ROHS COMPLIANT.

CHANGE DIM/ADD NOTES EC NO: ETC2007-0438 DRWN: CLYORK 2007/07/12 CHKD: JMACNEIL 2007/07/12 APPR: JMACNEIL 2007/07/13	QUALITY SYMBOLS ▽ = 0 ∇ = 0	GENERAL TOLERANCES (UNLESS SPECIFIED)		SCALE 2:1	DESIGN UNITS INCH	THIRD ANGLE PROJECTION	REVISE ON CAD ONLY			
				DIMENSION STYLE MM/IN		TITLE TERMINAL, SOLDER, Y SHORT, CAT. # 143				
				DRAWN BY R.STONE		DATE 08-18-03		MATERIAL NO. 380020159	DOCUMENT NO. SD-38002-005	SHEET NO. 1 OF 1
				CHECKED BY RK		DATE 2-5-04				
		ANGULAR ±1/2°		APPROVED BY GHR		DATE 2-26-04		THIS DRAWING CONTAINS INFORMATION THAT IS PROPRIETARY TO MOLEX INCORPORATED AND SHOULD NOT BE USED WITHOUT WRITTEN PERMISSION		
		DRAFT WHERE APPLICABLE MUST REMAIN WITHIN DIMENSIONS								

1	1	TERMINAL	BRASS	TIN PLATED
ITEM	QTY.	DESCRIPTION	MATERIAL	FINISH