

**SolderRight™
Insertion
Tool**

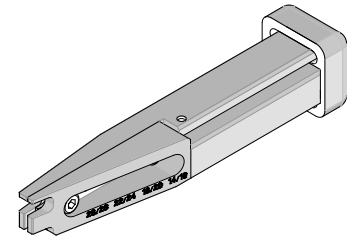

**Application Tooling
Specification Sheet**



Order No. 63812-1600

FEATURES

- This tool is designed for the insertion of crimped SolderRight™ terminals into a circuit board.
- Tool adjusts for different terminal sizes.
- Built-in down stop to ensure full terminal insertion into circuit board.

SCOPE

Products: SolderRight™ Right-Angle Direct Solder Terminals, In-Line Mount, 14AWG – 28AWG.

Terminal Series No.	Wire Size	Terminal Order No
172249	14AWG – 16AWG	172249-0100
	18AWG – 20AWG	172249-0200
172677	22AWG – 24AWG	172677-0100
	26AWG – 28AWG	172677-0200

ADJUSTMENTS

The insertion tool must be adjusted for the terminal size to be inserted. There is a movable insert in the tool held with two M2 screws. To adjust the insert, loosen (do not remove) the lower screw. Remove the upper screw and move it to the hole next to the wire size mark on the clamp, then tighten both screws. See Figure 1.

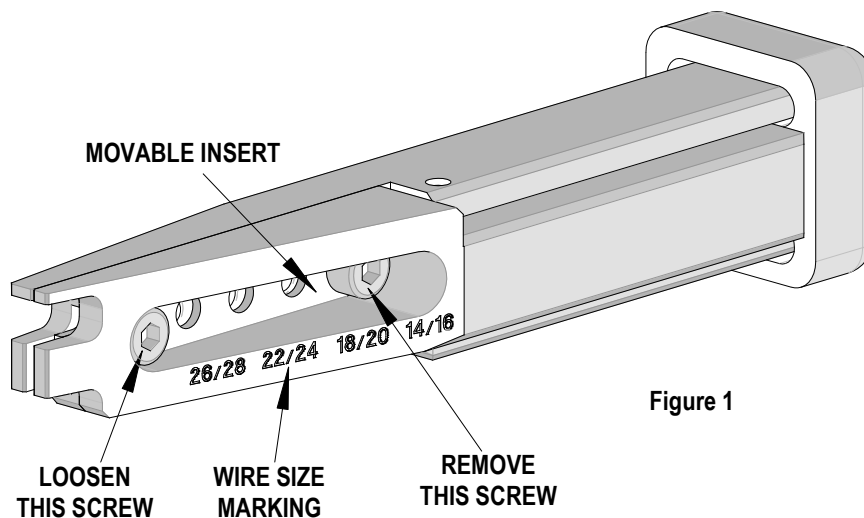

OPERATION

1. Open the terminal clamp by squeezing the end of the insertion tool by the handle. See Figure 2.
2. While holding the clamp open, load the terminal in the insertion tool so its flat side is against the insertion tool body. There is a stop in the tool for the end of the terminal. See Figure 3.

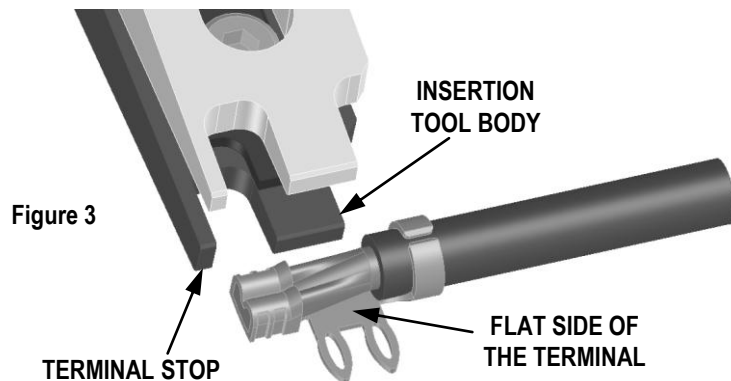
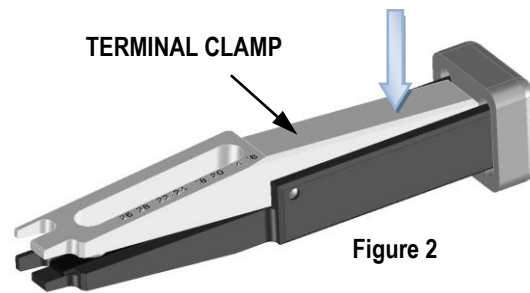

3. Release the clamp so it can close on the terminal and wire.
4. With the terminal clamped, insert the terminal into the circuit board. There is a down stop on the insertion tool to prevent over-insertion. See Figure 4.
5. Open the terminal clamp and remove the insertion tool from the terminal.

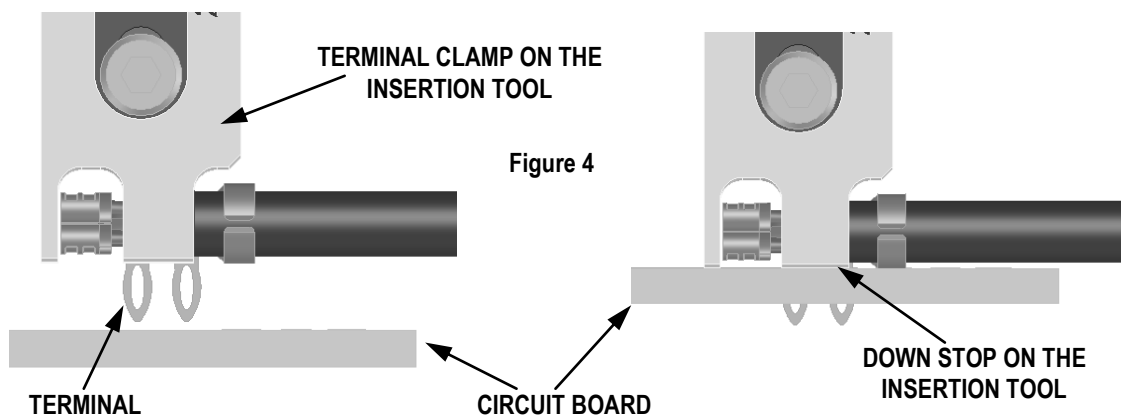

Molex does not offer repair parts for Insertion Tools due to the inexpensive nature of these tools.

CAUTION: Molex specifications are valid only when used with Molex terminals, modules, and tooling.

Contact Information

For more information on Molex application tooling please contact Molex at 1-800-786-6539.

Visit our Web site at <http://www.molex.com>