

Mechanical Dimensions: Inches [mm]

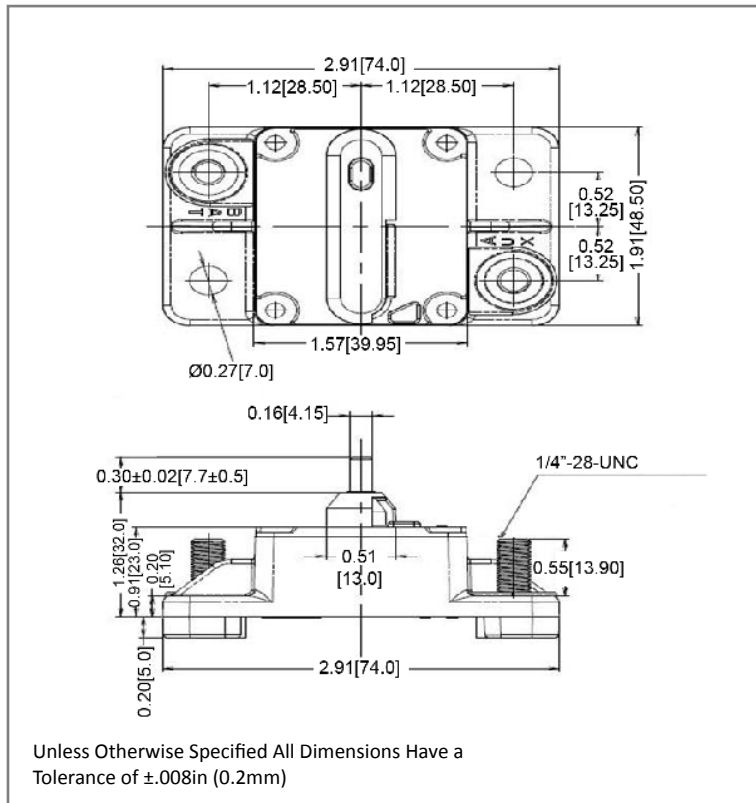

Part Numbers Information

Optifuse P/N	Current
153025	25A
153030	30A
153040	40A
153050	50A
153060	60A
153070	70A
153080	80A
153090	90A
153100	100A
153120	120A
153135	135A
153150	150A
153180	180A
153200	200A

Time vs. Percent of Rated Current

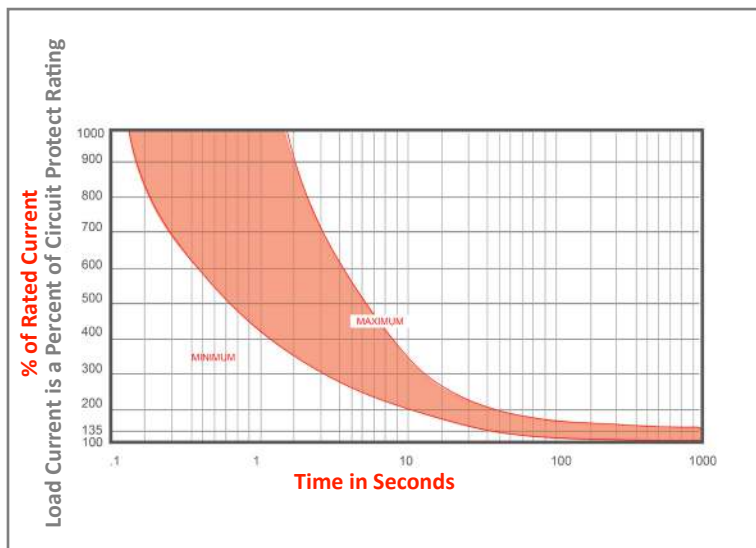

% of Rated Current	Min Hold Time	Max Hold Time
100%	No Trip (≥ 30 Minutes)	
135%	50s	30m
200%	12s	45s
300%	3.5s	15s

Trip time: Ambient temperature $25^{\circ}\text{C} \pm 3^{\circ}\text{C}$

Electrical Specifications

Voltage Rating	42VDC
Reset Type	Type III - Manual Reset
Interrupting Rating	3000A @ 30VDC
Operation Temperature	-25 °F ~ 180 °F -32 °C ~ 82 °C
Testing	SAE J1625, IEC 60934

Material Specifications

Heavy Duty High Amp - Waterproof Circuit Breaker	
Body Material	Thermoset Plastic (UL94V-0)
Terminals Configuration	1/4"-28 Stud
Mounting Type	Surface Mount
Ignition Protected	SAE J1171
Ingress Protection	IP67



Rev	Date of issue	Revision Notes	Designed	Approved
B	06-29-2023	Format Update	RC	OF