

THIS DRAWING IS UNPUBLISHED. RELEASED FOR PUBLICATION
 © COPYRIGHT - TE Connectivity Ltd. ALL RIGHTS RESERVED.

REVISIONS					
P	LTR	DESCRIPTION	DATE	DWN	APVD
	C	REVISED PER 0G3A-0369-02	10JUN02	JR	MJS
	C1	REVISED PER ECO-17-008808	07MAR2018	RS	DR

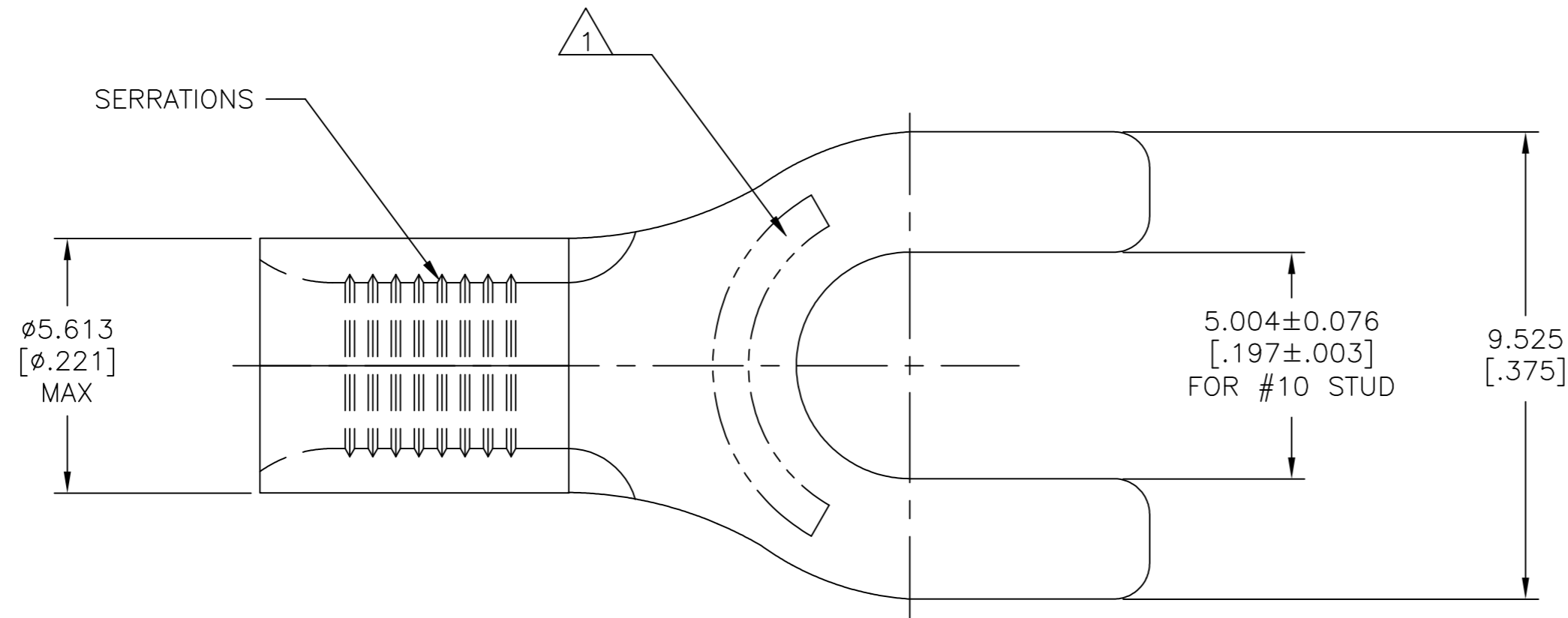

AMP WIRE RANGE	E13288 Listed
12-10 AWG STRANDED	12-10 AWG STRANDED
LR7189 Certified	MILITARY P/N AND CLASS
NOT CERTIFIED	NOT APPLICABLE

STAMP AMP 12-10* APPROX AS SHOWN

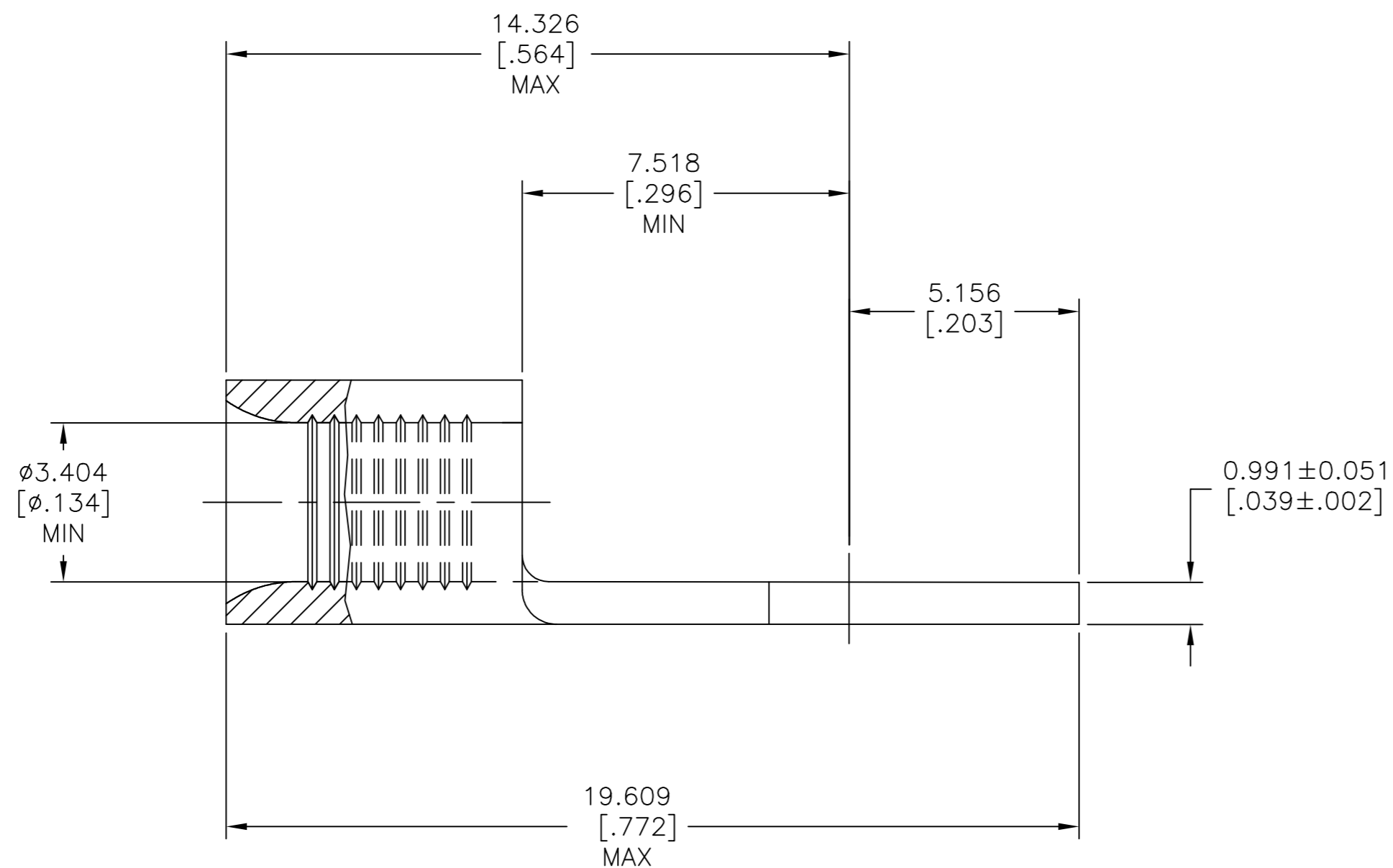

500	LOOSE PIECE	35494
QUANTITY	PACKAGE TYPE	PART NO

AMP INCORPORATED CUSTOMER SERVICE SYSTEMS			THIS DRAWING IS A CONTROLLED DOCUMENT.		DWN TA BRINKMAN 2-18-93	TE Connectivity Ltd. NAME TERMINAL, SPADE TONGUE, BUDGET, 12-10 AWG - SIZE CAGE CODE DRAWING NO RESTRICTED TO A2 00779 C=35494 - WEIGHT CUSTOMER DRAWING SCALE 8:1 SHEET 1 of 1 REV C1
FOR ADDITIONAL PRODUCT INFORMATION OR COPIES OF DRAWINGS AND TECHNICAL DOCUMENTS	PRODUCT INFORMATION CENTER 1-800-522-6752	MAX RECOMMENDED OPERATING TEMPERATURE: 170°C [338°F] MAX	DIMENSIONS: mm [INCHES]	TOLERANCES UNLESS OTHERWISE SPECIFIED:	CHK DA PATTERSON 2-18-93	
FOR APPLICATION TOOLING INFORMATION	TOOLING ASSISTANCE CENTER 1-800-722-1111	VOLTAGE RATING: NOT APPLICABLE		0 PLC ± - 1 PLC ± - 2 PLC ± - 3 PLC ± 0.127[.005] 4 PLC ± - ANGLES ± -	APVD DE MILLER 2-18-93	
FOR ORDER ENTRY	1-800-526-5142	WIRE CROSS SECTIONAL AREA RANGE, 2.62-6.64mm ² [5,180-13,100] CIR MILS STRANDED	MATERIAL COPPER PER ASTM B-152 ANNEALED	FINISH TIN PLATE 0.00254[.000100] MIN THK PER ASTM B545	PRODUCT SPEC UL 486 A-B APPLICATION SPEC -	