

XC74WL157ASR



CMOS Logic

- ◆ CMOS Logic 2-channel Multiplexer
- ◆ Operating Voltage Range : 2V ~ 5.5V
- ◆ High Speed Operations : tpd = 4.1ns(TYP.)
- ◆ Low Power Consumption : 2 μ A(MAX.)
- ◆ MSOP-8B Package

■ APPLICATIONS

- Palmtops
- Digital equipment

■ GENERAL DESCRIPTION

XC74WL157ASR is 2-channel multiplexer manufactured using silicon gate CMOS processes. The small quiescent current, which is one of the features of the CMOS logic, gives way to high speed operations which enables LS-TTL.

With wave forming buffers connected internally, stabilized output can be achieved as the series offers high noise immunity.

As the series is integrated into a mini molded, MSOP-8B package, high density mounting is possible.

■ FEATURES

High Speed Operations : tpd = 4.1ns(TYP.) (VCC=5V)

Operating Voltage Range : 2V ~ 5.5V

Low Power Consumption: 2 μ A (MAX.)

Small Package : MSOP-8B

■ PIN CONFIGURATION

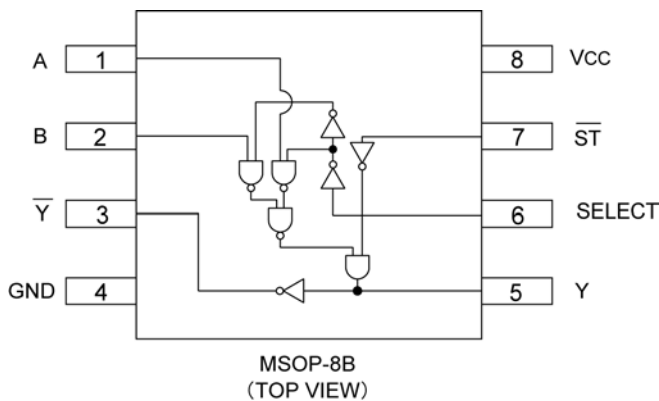

■ FUNCTIONS

INPUT				OUTPUT	
ST	SELECT	A	B	Y	Y
H	X	X	X	L	H
L	L	L	X	L	H
L	L	H	X	H	L
L	H	X	L	L	H
L	H	X	H	H	L

H=High level

L=Low level

X=Don't care

XC74WL157ASR

■ ABSOLUTE MAXIMUM RATINGS

Ta=-40°C~85°C

PARAMETER	SYMBOL	RATINGS	UNITS
Supply Voltage	V _{CC}	-0.5~+6.0	V
Input Voltage	V _{IN}	-0.5~+6.0	V
Output Voltage	V _{OUT}	-0.5~V _{CC} +0.5	V
Input Diode Current	I _{IK}	-20	mA
Output Diode Current	I _{OK}	± 20	mA
Switch Output Current	I _{OUT}	± 25	mA
V _{CC} ,GND Current	I _{CC} ,I _{GND}	± 50	mA
Power Dissipation (Ta = 25°C)	P _d	300	mW
Storage Temperature Range	T _{stg}	-65~+150	°C

Note : Voltage is all ground standardized.

■ RECOMMENDED OPERATING CONDITIONS

PARAMETER	SYMBOL	CONDITIONS	UNITS
Supply Voltage	V _{CC}	2~5.5	V
Input Voltage	V _{IN}	0~5.5	V
Output Voltage	V _{OUT}	0~V _{CC}	V
Operating Temperature Range	T _{opr}	-40~+85	°C
Input Rise and Fall Time	tr, tf	0~200 (V _{CC} =3.3V)	ns
		0~100 (V _{CC} =5V)	

■ DC ELECTRICAL CHARACTERISTICS

PARAMETER	SYMBOL	V _{CC} (V)	CONDITIONS	Ta=25°C			Ta=-40°C~85°C		UNITS		
				MIN.	TYP.	MAX.	MIN.	MAX.			
Input Voltage	V _{IH}	2.0		1.50	-	-	1.50	-	V		
		3.0		2.10	-	-	2.10	-			
		5.5		3.85	-	-	3.85	-			
	V _{IL}	2.0		-	-	0.50	-	0.50	V		
		3.0		-	-	0.90	-	0.90			
		5.5		-	-	1.65	-	1.65			
Output Voltage	V _{OH}	2.0	V _{IN} =V _{IH}	I _{OH} =-50μ A	1.90	2.00	-	1.90	-	V	
		3.0			2.90	3.00	-	2.90	-		
		4.5			4.40	4.50	-	4.40	-		
		3.0		I _{OH} =-4mA	2.58	-	-	2.48	-		
		4.5		I _{OH} =-8mA	3.94	-	-	3.80	-		
	V _{OL}	2.0	V _{IN} =V _{IL}	I _{OL} =50μ A	-	-	0.10	-	0.10	V	
		3.0			-	-	0.10	-	0.10		
		4.5			-	-	0.10	-	0.10		
		3.0			I _{OL} =4mA	-	-	0.36	-		0.44
		4.5			I _{OL} =8mA	-	-	0.36	-		0.44
Input Current	I _{IN}	0~5.5	V _{IN} =V _{CC} or GND	-0.10	-	0.10	-1.00	1.00	μ A		
Static Supply Current	I _{CC}	5.5	V _{IN} =V _{CC} or GND	-	-	2.00	-	20.0	μ A		

SWITCHING ELECTRICAL CHARACTERISTICS

(tr=tf=3ns)

PARAMETER	SYMBOL	CONDITIONS		Ta=25°C			Ta=-40°C~85°C		UNITS
		CL	Vcc(V)	MIN.	TYP.	MAX.	MIN.	MAX.	
Delay Time (A, B-Y, \overline{Y})	tPLH	15pF	3.3	-	6.2	9.7	1.0	11.5	ns
			5.0	-	4.1	6.4	1.0	7.5	
		50pF	3.3	-	8.7	13.2	1.0	15.0	ns
			5.0	-	5.6	8.4	1.0	9.5	
	tPHL	15pF	3.3	-	6.2	9.7	1.0	11.5	ns
			5.0	-	4.1	6.4	1.0	7.5	
		50pF	3.3	-	8.7	13.2	1.0	15.0	ns
			5.0	-	5.6	8.4	1.0	9.5	
Delay Time (SEDECT-Y, \overline{Y})	tPLH	15pF	3.3	-	8.4	13.2	1.0	15.5	ns
			5.0	-	5.3	8.1	1.0	9.5	
		50pF	3.3	-	10.9	16.7	1.0	19.0	ns
			5.0	-	6.8	10.1	1.0	11.5	
	tPHL	15pF	3.3	-	8.4	13.2	1.0	15.5	ns
			5.0	-	5.3	8.1	1.0	9.5	
		50pF	3.3	-	10.9	16.7	1.0	19.0	ns
			5.0	-	6.8	10.1	1.0	11.5	
Delay Time (\overline{ST} -Y, Y)	tPLH	15pF	3.3	-	8.7	13.6	1.0	16.0	ns
			5.0	-	5.6	8.6	1.0	10.0	
		50pF	3.3	-	11.2	17.1	1.0	19.5	ns
			5.0	-	7.1	10.6	1.0	12.0	
	tPHL	15pF	3.3	-	8.7	13.6	1.0	16.0	ns
			5.0	-	5.6	8.6	1.0	10.0	
		50pF	3.3	-	11.2	17.1	1.0	19.5	ns
			5.0	-	7.1	10.6	1.0	12.0	
Input Capacitance	CIN	-	-	-	4	10	-	10	pF
Power Dissipation Capacitance	Cpd	-	-	-	20	-	-	-	pF

NOISE CHARACTERISTICS

(tr=tf=3ns)

PARAMETER	SYMBOL	CONDITIONS		Ta=25°C			UNITS
		CL	Vcc(V)	MIN.	TYP.	MAX.	
Non Functional Output Maximum Dynamic VOL	VOLP	50pF	5.0	-	0.3	0.8	V
Non Functional Output Minimum Dynamic VOL	VOLV	50pF	5.0	-0.8	-0.3	-	V
Minimum Dynamic VIH	VIHD	50pF	5.0	-	-	3.5	V
Maximum Dynamic VIL	VILD	50pF	5.0	-	-	1.5	V

XC74WL157ASR

■ TEST CIRCUIT

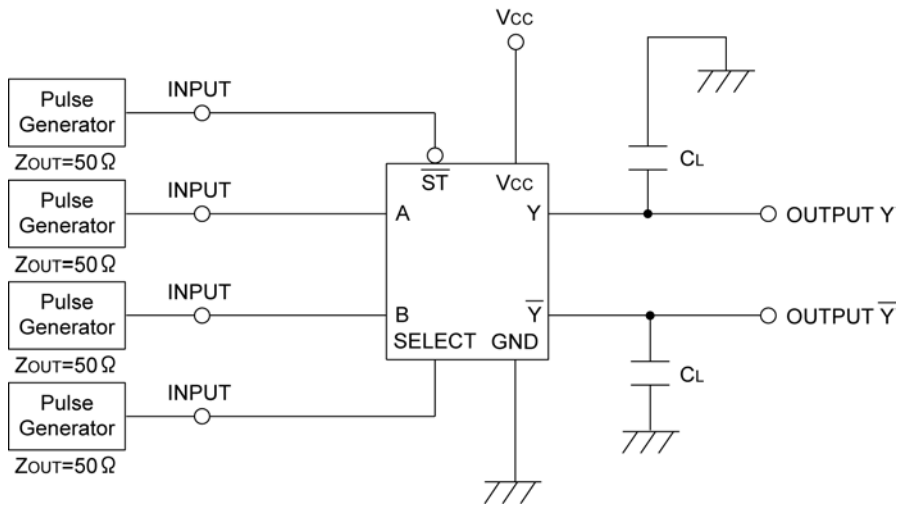

■ WAVEFORM

