

PART NUMBER	REVISION	DESCRIPTION	FEED TYPE
2150082-1	G	FINE CRIMP HEIGHT ADJUST	MECHANICAL
2150082-2	G	FINE CRIMP HEIGHT ADJUST	PNEUMATIC
7-2150082-1	G	MECHANICAL AND CRIMP TOOLING KIT	MECHANICAL
7-2150082-2	G	PNEUMATIC AND CRIMP TOOLING KIT	PNEUMATIC
7-2150082-7	A	CRIMP TOOLING KIT	-

ATLANTIC VERSION TERMINATOR INTERFACE ADAPTER

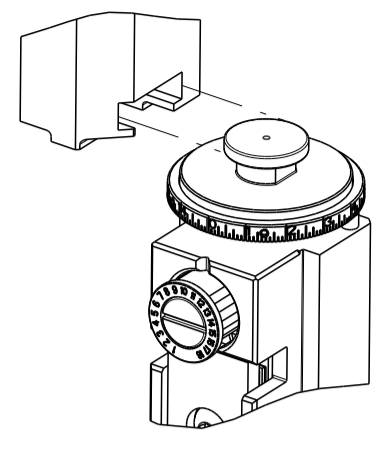

APPLICATOR DATA		
CRIMP SIZE	TYPE	
WIRE 2.29 mm [.090]	F	
INSUL 3.30 mm [.130]	F	
APPL INSTRUCTIONS 408-35043		

TERMINAL DATA: TE TERMINAL		TE CRIMP SPECIFICATION	
TERMINAL NAME: FASTON CONNECTOR .250 SR REC CONTACT			
WIRE STRIP LENGTH	INSULATION DIAMETER RANGE		
SEE APPL. SPEC.	Ø2.30-3.30 mm [.091-.130 IN]		
TERMINAL APPLICATION SPECIFICATION	(A)114-19025	-	-
	(B)114-20023	-	-
TERMINALS APPLIED			
TE TERMINAL	TE TERMINAL	TE TERMINAL	TE TERMINAL
(A) 100495-1	(A) 100495-2	(A) 100495-4	(B) 5-160432-3
(B) 5-160432-4	(B) 5-160432-5	(B) 5-160432-7	(B) 6-160432-0
(B) 6-160432-3	(B) 6-160432-4	(B) 7-160432-0	(B) 160744-1
(B) 160769-1	(B) 160807-2		

WIRE SIZE	CRIMP HEIGHT mm [INCH]	CRIMP HEIGHT REFERENCE SETTING
1.50mm2	1.65 +/- 0.05 [.065 +/- .002]	3.2
1.00mm2	1.60 +/- 0.05 [.063 +/- .002]	3.7
0.75mm2	1.50 +/- 0.05 [.059 +/- .002]	4.7
0.50mm2	1.45 +/- 0.05 [.057 +/- .002]	5.2

- 1 RECOMMENDED SPARE PARTS
- 2 REFER TO SUPPLIED INSTRUCTION SHEET FOR CLEANING, LUBRICATION AND STORAGE OF APPLICATOR.
- 3 APPLY PART NUMBER 2-23419-6 LOCTITE TO THREADS OF ITEM 242. APPLY PART NUMBER 1-23419-5 LOCTITE TO THREADS OF ITEM 50.
- 4 CRIMP HEIGHT REFERENCE SETTING WAS THE SETTING USED WHEN THE APPLICATOR WAS QUALIFIED AT THE FACTORY. ADJUSTMENT MAY BE NECESSARY WHEN RUNNING APPLICATOR IN THE FIELD.
- 5 UNLESS SPECIFIED OTHERWISE TORQUE VALUES SHALL BE USED PER DOCUMENT, 101-35000.
- 6 TERMINAL LUBRICANT IS RECOMMENDED.

**\*WARNING**  
ON INSTALLATION, SET WIRE DISC TO CRIMP HEIGHT REFERENCE SETTING FOR LARGEST WIRE SIZE. CRIMP HEIGHT REFERENCE SETTINGS GREATER THAN THE VALUE SHOWN MAY CAUSE DAMAGE TO THE CRIMP TOOLING, REFER TO THE INSTRUCTION SHEET FOR PROPER SETUP AND ADJUSTMENTS.

LOC	DIST	REVISIONS					
A	66	P	LTN	DESCRIPTION	DATE	OWN	APVD
		D		ECR-15-000168	06JAN2015	MR	GB
		E		ECR-18-012465	07AUG2018	YY	TE
		F		ECR-20-014292	08OCT2020	MEH	RK
		G		ECR-21-006127	08JUN2021	TB	TE

-	1	-	1	-	2119641-1	FEED CAM, AIR FEED	248	
-	1	1	1	1	2119082-9	CAM, SNAIL, INSULATION ADJUSTMENT	244	
-	1	1	1	1	2079764-1	WASHER, WAVE SPRING, CREST-TO-CREST	243	
-	1	1	1	1	2119083-1	RETAINER, INSULATION DIAL	242	
-	-	1	-	-	2119580-1	MECHANICAL FEED ASSEMBLY	239	
-	1	-	1	-	2844940-3	AIR FEED MODULE	238	
-	1	1	1	1	1-18028-0	WASHER, FLAT, REG M8	192	
-	1	1	1	1	6-993111-6	PIN, SLOTTED SPRING 3.0 X 14.0	177	
-	1	1	1	1	8-22280-7	SPRING, COMPRESSION	176	
-	1	1	1	1	1752353-2	GUIDE PIN,HOLDDOWN	175	
-	1	1	1	1	1901680-2	GUIDE PIN,HOLDDOWN	174	
-	REF	REF	REF	REF	994970-2	COUNTER, MAGNETIC	164	
-	1	1	1	1	2119955-2	ASSY, LUBRICATOR, END FEED	84	
-	1	1	1	1	455888-6	SPACER, CRIMPER	82	
-	1	1	1	1	2119791-9	DEPRESSOR, WIRE	73	
-	1	1	1	1	1803607-4	DOCUMENTATION PACKAGE	71	
-	2	2	2	2	2-18032-2	SCR, SET, FLT PNT, M3 X 10.0	70	
-	1	1	1	1	2119740-1	TAG, IDENTIFICATION	67	
-	2	2	2	2	2168078-1	SCREW, DRIVE, RH, RoHS, 2 x .188	66	
-	1	1	1	1	1901681-1	HOLDDOWN, TERMINAL	65	
-	1	1	1	1	2168083-2	SCR, SKT HD CAP, RoHS, M4 X 8.0	60	
-	1	1	1	1	5-18022-5	SCR, HEX HD CAP, M4 X 6.0	59	
-	-	1	-	-	2063961-9	FEED FINGER	58	
-	4	4	4	4	2168400-4	SHCS, LOW HEAD, RoHS, M4 X 8	57	
-	2	2	2	2	2168083-3	SCR, SKT HD CAP, RoHS, M4 X 12.0	56	
-	2	2	2	2	5018030-1	NUT, HEX, REG, RoHS, M3	54	
-	2	2	2	2	986965-8	NUT, LOCK, HEX, TORQUE (M4)	53	
-	1	1	1	1	1-5018030-0	NUT, HEX, REG, RoHS, M3.5	52	
-	1	-	1	-	1-2063961-0	FEED FINGER	51	
-	1	1	1	1	1-1752354-2	STANDOFF,HOLD-DOWN	50	
-	1	2	1	2	18023-9	SCR, SKT HD CAP M4 X 6.0	49	
-	-	1	-	-	2119652-1	FEED CAM, PRE FEED	48	
-	-	1	-	-	2119653-1	FEED CAM, POST FEED	47	
-	1	1	1	1	2119655-5	APPLICATOR BASIC ASSEMBLY, EF	46	
-	1	1	1	1	1803517-1	RAM ASSEMBLY, EF ATLANTIC	44	
-	1	1	1	1	1803602-1	SCR, BHSC, RoHS (M8 X 25)	41	
-	8	8	8	8	1-18028-2	WASHER, FLAT, REG M4	33	
-	2	2	2	2	2168083-9	SCR, SKT HD CAP, RoHS, M4 X 20	31	
-	2	2	2	2	2168083-2	SCR, SKT HD CAP, RoHS, M4 X 8.0	29	
-	1	1	1	1	240639-1	STRIPPER (MACHINING)	27	
-	2	2	2	2	1-2168083-5	SCR, SKT HD CAP, RoHS, M4 X 30	25	
-	1	1	1	1	1752371-5	PLATE, STRIP GUIDE	24	
-	2	2	2	2	2-22281-3	SPRING, COMPRESSION	22	
-	1	1	1	1	1803292-4	DRAG	20	
-	1	1	1	1	1803152-1	STRIP GUIDE, REAR	19	
-	1	1	1	1	1803151-1	STRIP GUIDE, FRONT	18	
-	4	4	4	4	1-2079383-1	SCR, BHSC, RoHS (M6 X 12)	17	
-	1	1	1	1	1752360-1	SPACER,HOLD-DOWN	13	
-	1	1	1	1	240644-1	PLATE, REAR SHEAR	11	
-	-	-	-	-	-	-	10	
-	1	1	1	1	690482-3	PLATE, FRONT SHEAR	9	
-	1	2	2	1	1333217-1	ANVIL, EF .090	8	
-	1	1	1	1	690474-9	BLADE, SLUG	7	
-	1	1	1	1	6-240641-5	SPACER	5	
-	1	1	1	1	238011-2	BLOCK, CRIMPER SPACER	4	
-	1	2	2	1	2-1633961-6	CRIMPER, INSULATION F PREMIUM	3	
-	1	1	1	1	455888-6	SPACER, CRIMPER	2	
-	1	2	2	1	4-456406-5	CRIMPER, WIRE PREMIUM	1	
-	77	72	71	2	-1	PART NO	DESCRIPTION	ITEM NO

ATLANTIC VERSION  
Shown on sheets 1 of 4 & 2 of 4  
(Pacific version shown on sheets 3 of 4 & 4 of 4)

DIMENSIONS:		TOLERANCES UNLESS OTHERWISE SPECIFIED:		DWN C. CHEN 14FEB2012		CHK S. XI 14FEB2012		APVD J. CRUZ 14FEB2012		NAME	
mm	0 PLC ±	1 PLC ±	2 PLC ±	3 PLC ±	4 PLC ±	TE Connectivity		Harrisburg, PA 17105-3608		Ocean End Feed Applicator	
MATERIAL		FINISH		WEIGHT		SIZE		CAGE CODE		DRAWING NO	
						A1		00779		C=2150082	
						Customer Accessible Production Drawing		SCALE		SHEET 1 of 4	
								REV		G	

LOC	DIST	REVISIONS					
A	66	P	LTM	DESCRIPTION	DATE	OWN	APVD
		-		SEE SHEET 1			

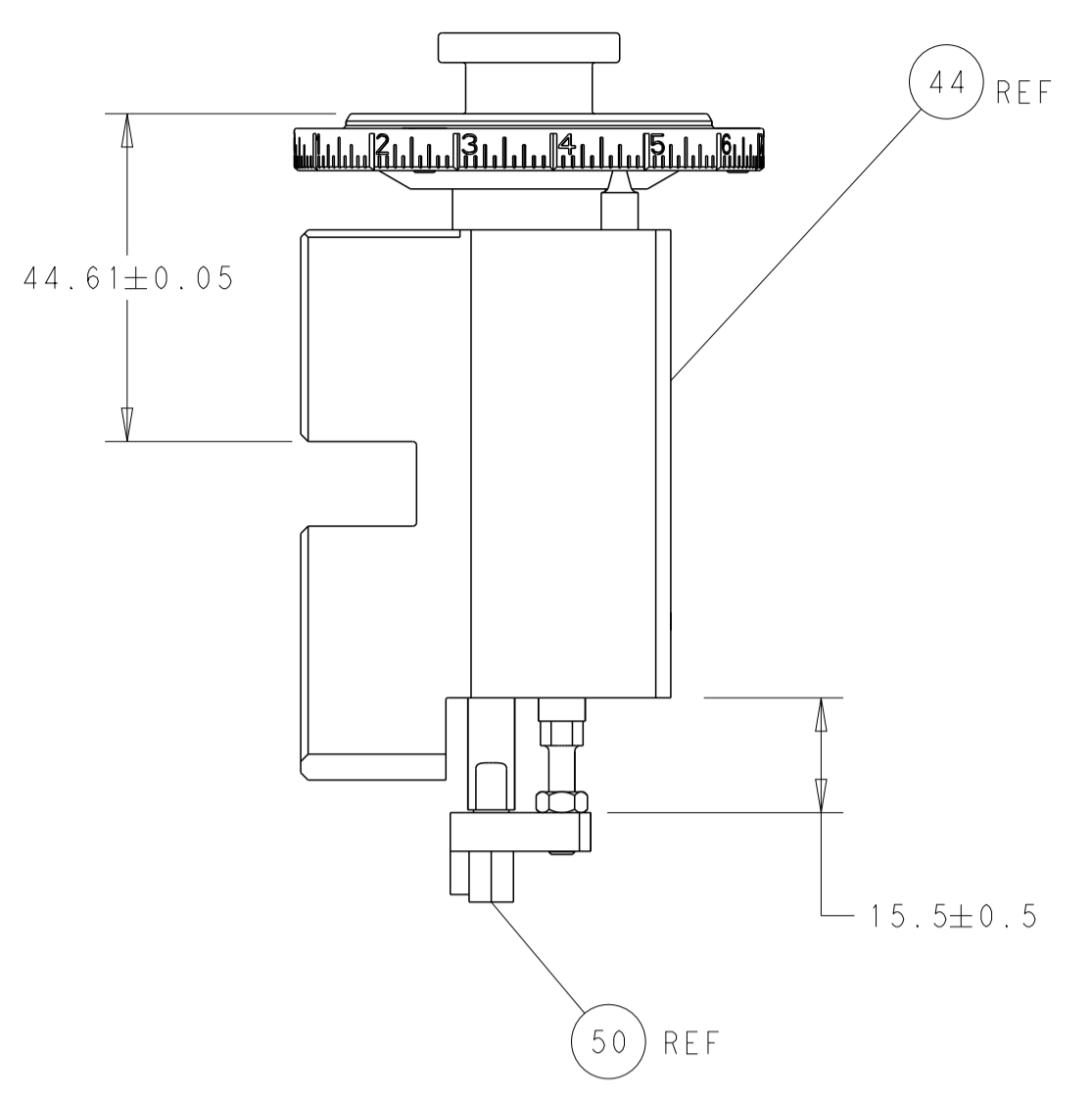

RAM AND HOLDDOWN SET-UP

FEED TYPE  
 MECHANICAL

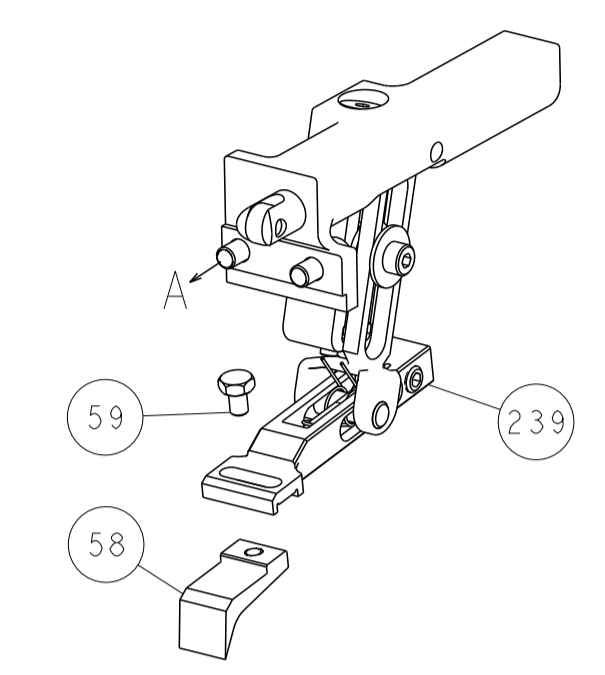

PNEUMATIC

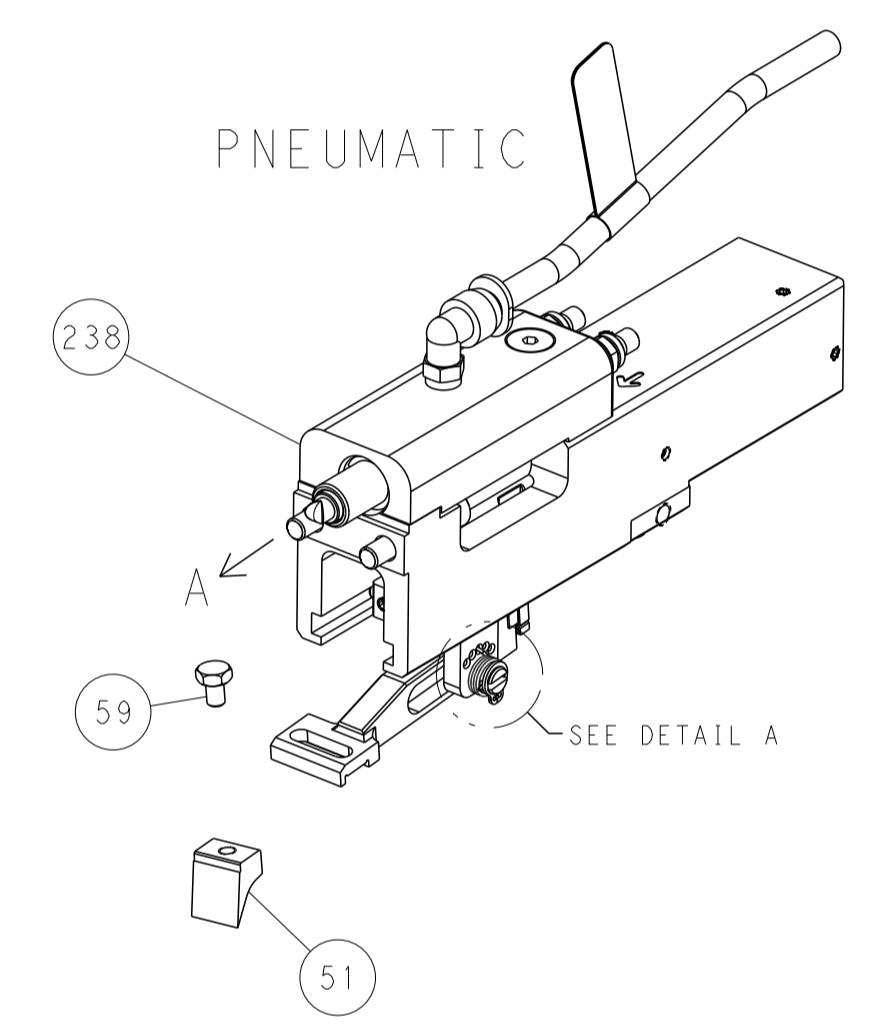

FEED SPRING  
 SETTING POSITION

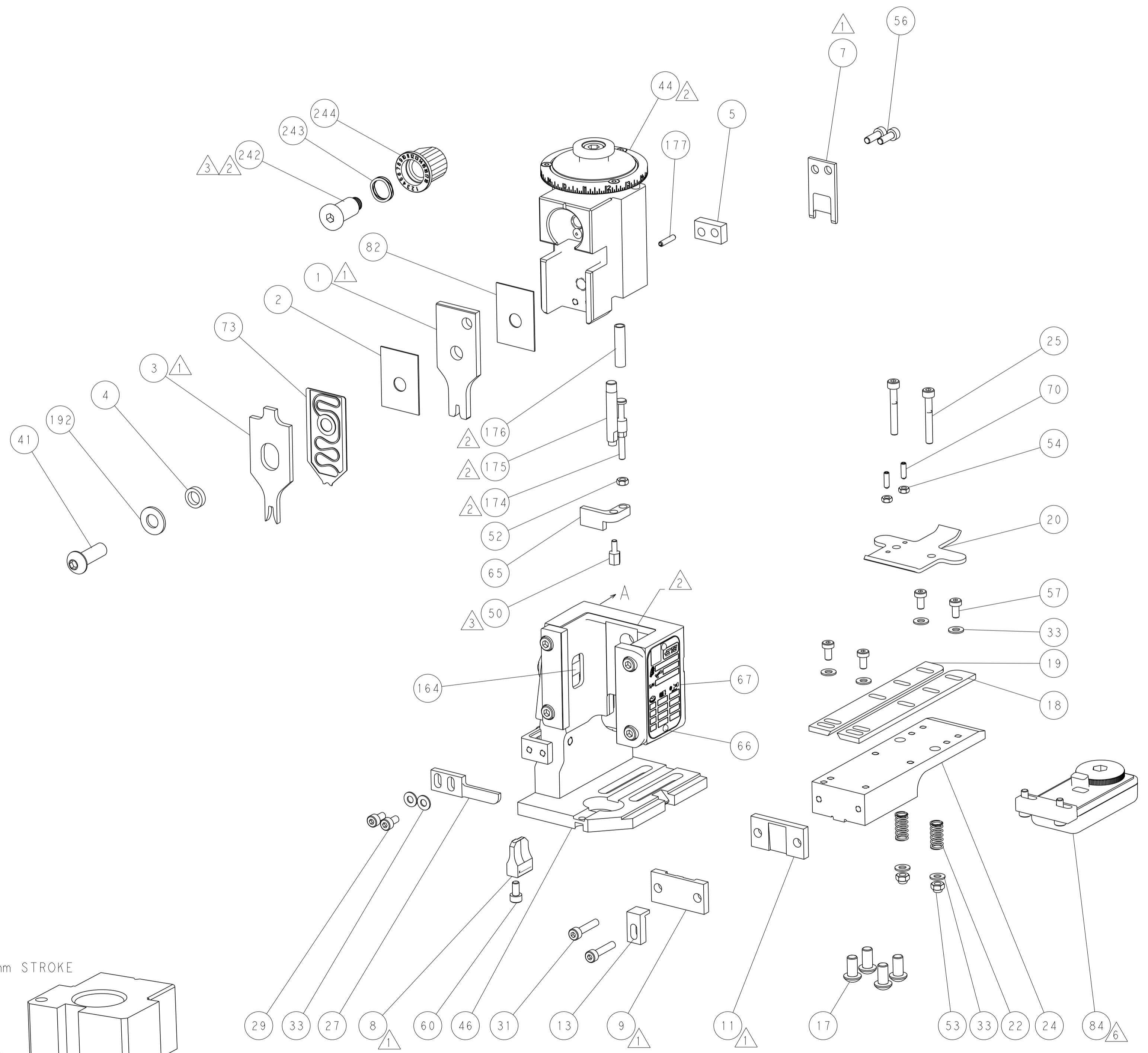
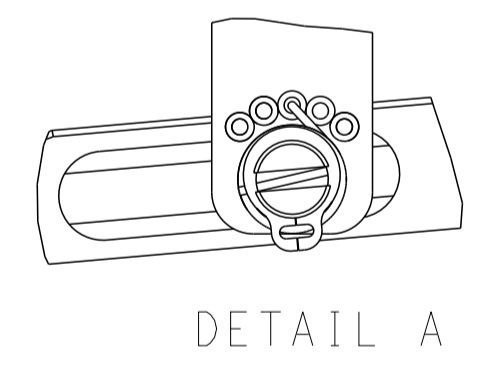

CAM POSITIONS

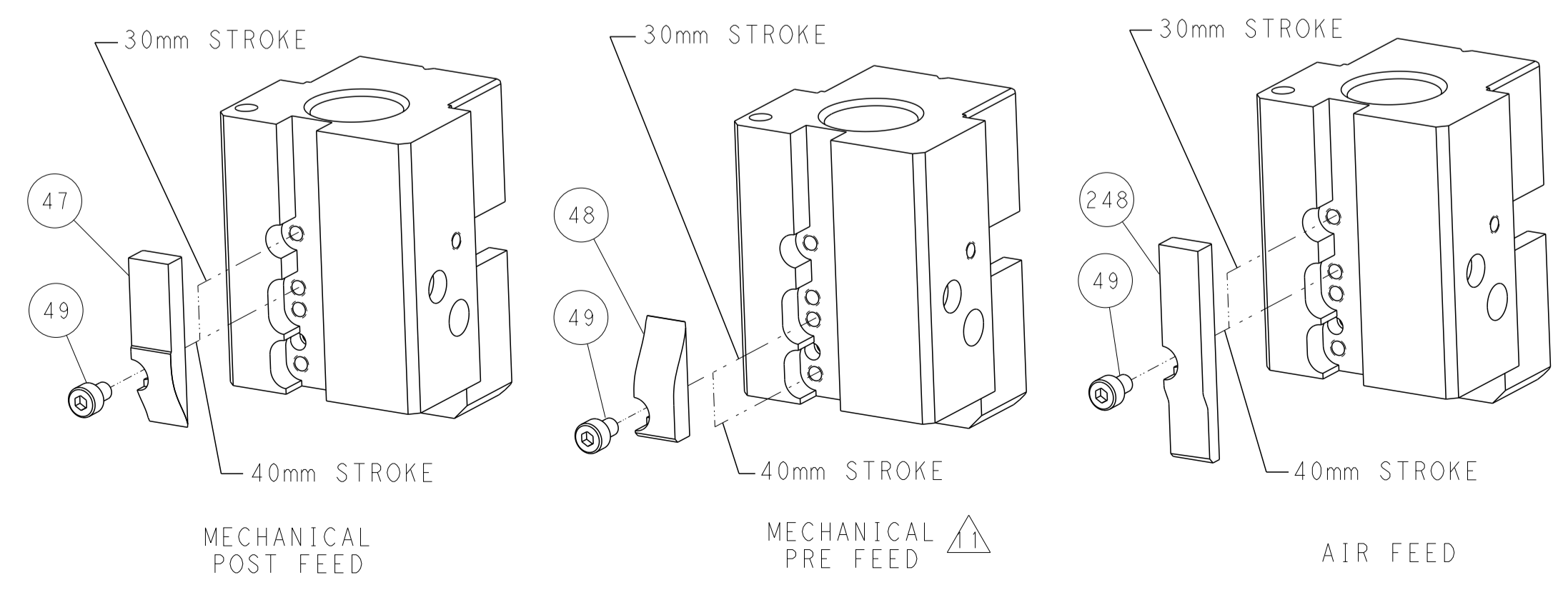

ATLANTIC VERSION  
 Shown on sheets 1 of 4 & 2 of 4  
 (Pacific version shown on sheets 3 of 4 & 4 of 4)

<small>THIS DRAWING IS UNPUBLISHED. RELEASED FOR PUBLICATION BY TYCO ELECTRONICS CORPORATION. ALL RIGHTS RESERVED.</small>		DWN C. CHEN 14FEB2012 CHK S. XI 14FEB2012 APVD J. CRUZ 14FEB2012	TE Connectivity Harrisburg, PA 17105-3608
DIMENSIONS: mm TOLERANCES UNLESS OTHERWISE SPECIFIED: 0 PLC ± 1 PLC ± 2 PLC ± 3 PLC ± 4 PLC ± ANGLES ± FINISH		NAME Ocean End Feed Applicator SIZE CAGE CODE DRAWING NO A 00779 C-2150082	RESTRICTED TO SCALE 1:1 SHEET 2 OF 4 REV G
MATERIAL:		WEIGHT:	Customer Accessible Production Drawing

PART NUMBER	REVISION	DESCRIPTION	FEED TYPE
2-2150082-1	G	FINE CRIMP HEIGHT ADJUST	MECHANICAL
2-2150082-2	G	FINE CRIMP HEIGHT ADJUST	PNEUMATIC
7-2150082-7	A	CRIMP TOOLING KIT	-

PACIFIC VERSION TERMINATOR  
 INTERFACE ADAPTER

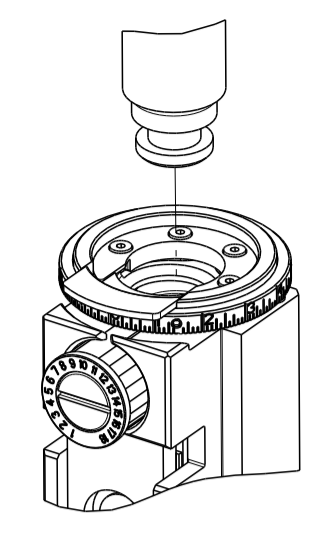

APPLICATOR DATA

CRIMP	SIZE	TYPE
WIRE	2.29 mm (.090)	F
INSUL	3.30 mm (.130)	F

APPL INSTRUCTIONS  
 408-35043

TERMINAL DATA: TE TERMINAL TE CRIMP SPECIFICATION

TERMINAL NAME: FASTON CONNECTOR .250 SR REC CONTACT

WIRE STRIP LENGTH	INSULATION DIAMETER RANGE
SEE APPL. SPE.	∅2.30-3.30 mm (.091-.130 IN)

TERMINAL APPLICATION SPECIFICATION (A)114-19025 (B)114-20023

TERMINALS APPLIED

TE TERMINAL	TE TERMINAL	TE TERMINAL	TE TERMINAL
(A) 100495-1	(A) 100495-2	(A) 100495-4	(B) 5-160432-3
(B) 5-160432-4	(B) 5-160432-5	(B) 5-160432-7	(B) 6-160432-0
(B) 6-160432-3	(B) 6-160432-4	(B) 7-160432-0	(B) 160744-1
(B) 160769-1	(B) 160807-2		

WIRE SIZE	CRIMP HEIGHT mm [INCH]	CRIMP HEIGHT REFERENCE SETTING
1.50mm2	1.65+/-0.05 [.065+/-0.002]	3.2
1.00mm2	1.60+/-0.05 [.063+/-0.002]	3.7
0.75mm2	1.50+/-0.05 [.059+/-0.002]	4.7
0.50mm2	1.45+/-0.05 [.057+/-0.002]	5.2

- 1 RECOMMENDED SPARE PARTS
- 2 REFER TO SUPPLIED INSTRUCTION SHEET FOR CLEANING, LUBRICATION AND STORAGE OF APPLICATOR.
- 3 APPLY PART NUMBER 2-23419-6 LOCTITE TO THREADS OF ITEM 242. APPLY PART NUMBER 1-23419-5 LOCTITE TO THREADS OF ITEM 50.
- 4 CRIMP HEIGHT REFERENCE SETTING WAS THE SETTING USED WHEN THE APPLICATOR WAS QUALIFIED AT THE FACTORY. ADJUSTMENT MAY BE NECESSARY WHEN RUNNING APPLICATOR IN THE FIELD.
- 5 UNLESS SPECIFIED OTHERWISE TORQUE VALUES SHALL BE USED PER DOCUMENT, 101-35000.
- 6 TERMINAL LUBRICANT IS RECOMMENDED.

**\*WARNING**  
 ON INSTALLATION, SET WIRE DISC TO CRIMP HEIGHT REFERENCE SETTING FOR LARGEST WIRE SIZE. CRIMP HEIGHT REFERENCE SETTINGS GREATER THAN THE VALUE SHOWN MAY CAUSE DAMAGE TO THE CRIMP TOOLING, REFER TO THE INSTRUCTION SHEET FOR PROPER SETUP AND ADJUSTMENTS.

LOC	DIST	REVISIONS					
A	66	P	LTN	DESCRIPTION	DATE	OWN	APVD
		-	-	SEE SHEET 1	-	-	-

-	1	1	2119082-9	CAM, SNAIL, INSULATION ADJUSTMENT	244	
-	1	1	2079764-1	WASHER, WAVE SPRING, CREST-TO-CREST	243	
-	1	1	2119083-1	RETAINER, INSULATION DIAL	242	
-	-	1	2119580-1	MECHANICAL FEED ASSEMBLY	239	
-	1	-	2844940-3	AIR FEED MODULE	238	
-	1	1	1-18028-0	WASHER, FLAT, REG M8	192	
-	4	4	2079383-9	SCR, BHSC, RoHS (M6 X 20)	186	
-	1	1	6-993111-6	PIN, SLOTTED SPRING 3.0 X 14.0	177	
-	1	1	8-22280-7	SPRING, COMPRESSION	176	
-	1	1	1752353-2	GUIDE PIN,HOLDDOWN	175	
-	1	1	1901680-2	GUIDE PIN,HOLDDOWN	174	
-	REF	REF	994970-2	COUNTER, MAGNETIC	164	
-	1	-	2119641-2	FEED CAM, AIR FEED	152	
-	1	1	2168083-8	SCR, SKT HD CAP, RoHS, M4 X 16	144	
-	-	1	2119653-2	FEED CAM, POST FEED	142	
-	1	1	2119655-6	APPLICATOR BASIC ASSEMBLY, EF	141	
-	1	1	1803518-1	RAM ASSEMBLY, EF PACIFIC	140	
-	1	1	2119955-2	ASSY, LUBRICATOR, END FEED	84	
-	1	1	455888-6	SPACER, CRIMPER	82	
-	1	1	2119791-9	DEPRESSOR, WIRE	73	
-	1	1	1803607-4	DOCUMENTATION PACKAGE	71	
-	2	2	2-18032-2	SCR, SET, FLT PNT, M3 X 10.0	70	
-	1	1	2119740-1	TAG,IDENTIFICATION	67	
-	2	2	2168078-1	SCREW, DRIVE, RH, RoHS, 2 x .188	66	
-	1	1	1901681-1	HOLDDOWN, TERMINAL	65	
-	1	1	5-18022-5	SCR, HEX HD CAP, M4 X 6.0	59	
-	-	1	2063961-9	FEED FINGER	58	
-	4	4	2168400-4	SHCS, LOW HEAD, RoHS, M4 X 8	57	
-	2	2	2168083-3	SCR, SKT HD CAP, RoHS, M4 X 12.0	56	
-	2	2	5018030-1	NUT, HEX, REG, RoHS, M3	54	
-	2	2	986965-8	NUT, LOCK, HEX, TORQUE (M4)	53	
-	1	1	1-5018030-0	NUT, HEX, REG, RoHS, M3.5	52	
-	1	-	1-2063961-0	FEED FINGER	51	
-	1	1	1-1752354-2	STANDOFF,HOLD-DOWN	50	
-	1	2	18023-9	SCR, SKT HD CAP M4 X 6.0	49	
-	-	1	2119652-1	FEED CAM, PRE FEED	48	
-	1	1	1803602-1	SCR, BHSC, RoHS (M8 X 25)	41	
-	8	8	1-18028-2	WASHER, FLAT, REG M4	33	
-	2	2	2168083-9	SCR, SKT HD CAP, RoHS, M4 X 20	31	
-	2	2	2168083-2	SCR, SKT HD CAP, RoHS, M4 X 8.0	29	
-	1	1	240639-1	STRIPPER (MACHINING)	27	
-	2	2	1-2168083-5	SCR, SKT HD CAP, RoHS, M4 X 30	25	
-	1	1	1752371-5	PLATE, STRIP GUIDE	24	
-	2	2	2-22281-3	SPRING, COMPRESSION	22	
-	1	1	1803292-4	DRAG	20	
-	1	1	1803152-1	STRIP GUIDE, REAR	19	
-	1	1	1803151-1	STRIP GUIDE, FRONT	18	
-	1	1	1752360-1	SPACER,HOLD-DOWN	13	
-	1	1	240644-1	PLATE, REAR SHEAR	11	
-	-	-	-	-	10	
-	1	1	690482-3	PLATE, FRONT SHEAR	9	
1	1	1	1333217-1	ANVIL, EF .090	8	
-	1	1	690474-9	BLADE, SLUG	7	
-	1	1	6-240641-5	SPACER	5	
-	1	1	238011-2	BLOCK, CRIMPER SPACER	4	
1	1	1	2-1633961-6	CRIMPER, INSULATION F PREMIUM	3	
-	1	1	455888-6	SPACER, CRIMPER	2	
1	1	1	4-456406-5	CRIMPER, WIRE PREMIUM	1	
-	77	22	21	PART NO	DESCRIPTION	ITEM NO

PACIFIC VERSION  
 Shown on sheets 3 of 4 & 4 of 4  
 (Atlantic version shown on sheets 1 of 4 & 2 of 4)

DIMENSIONS: mm 		TOLERANCES UNLESS OTHERWISE SPECIFIED: 0 PLC ± 1 PLC ± 2 PLC ± 3 PLC ± 4 PLC ± ANGLES ± FINISH		DWN C. CHEN 14FEB2012 CHK S. XI 14FEB2012 APVD J. CRUZ 14FEB2012 PRODUCT SPEC APPLICATION SPEC WEIGHT SCALE 1:1 SHEET 3 OF 4 REV G		NAME Ocean End Feed Applicator SIZE CAGE CODE DRAWING NO A1 00779 C=2150082 RESTRICTED TO Customer Accessible Production Drawing	
-----------------------	--	---	--	--	--	---	--

LOC		DIST		REVISIONS			
A	66	P	LTM	DESCRIPTION	DATE	OWN	APVD
		-		SEE SHEET 1			

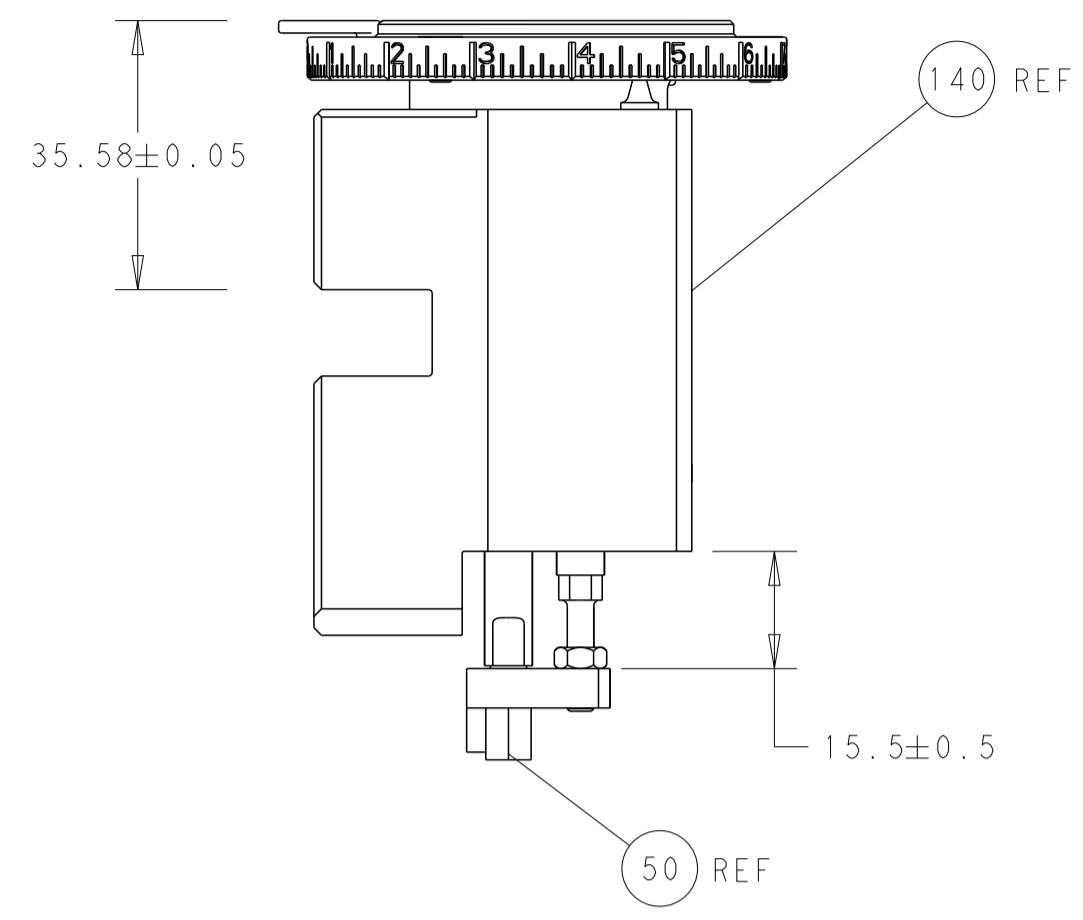

RAM AND HOLDDOWN SET-UP

FEED TYPE  
MECHANICAL

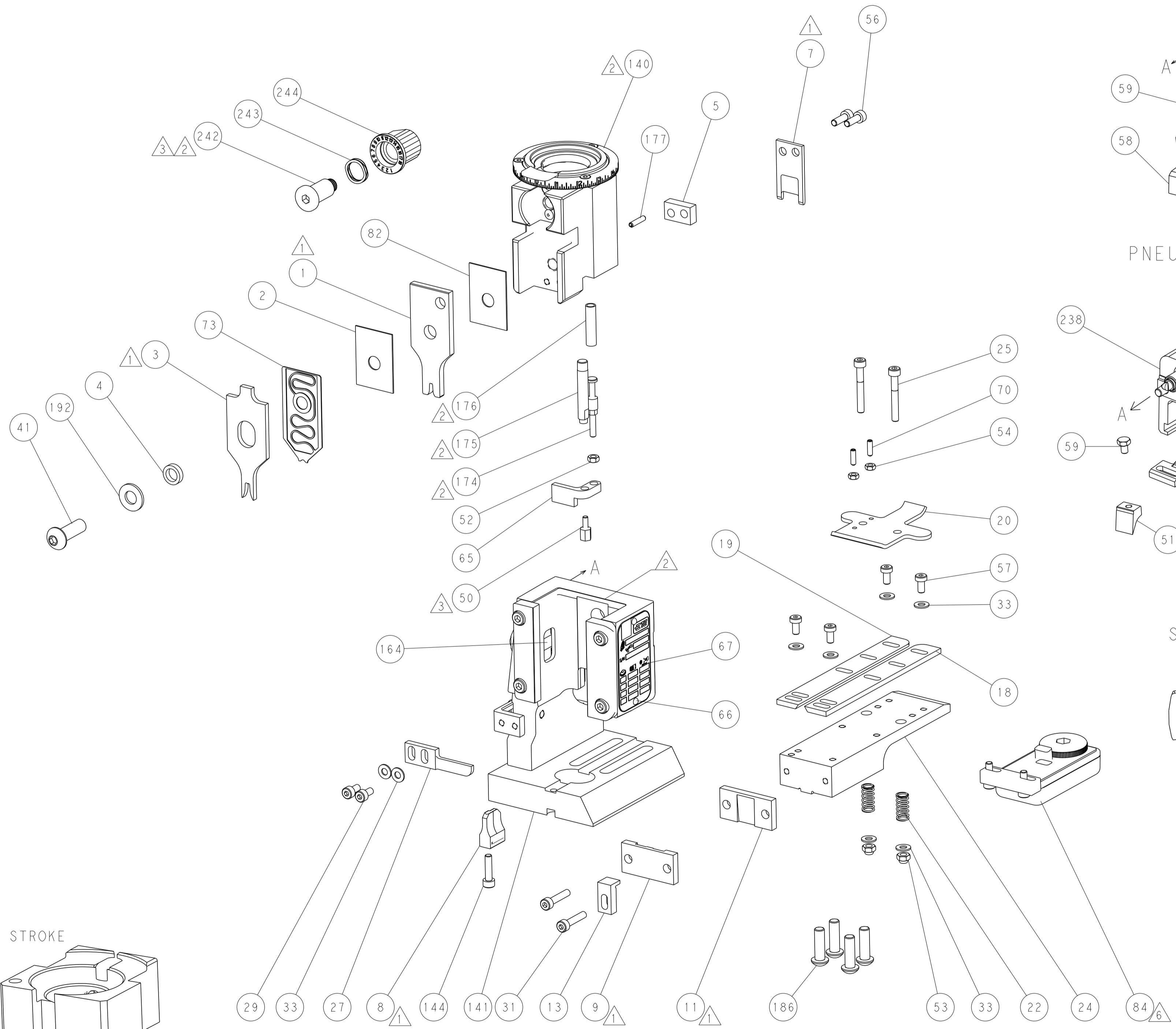
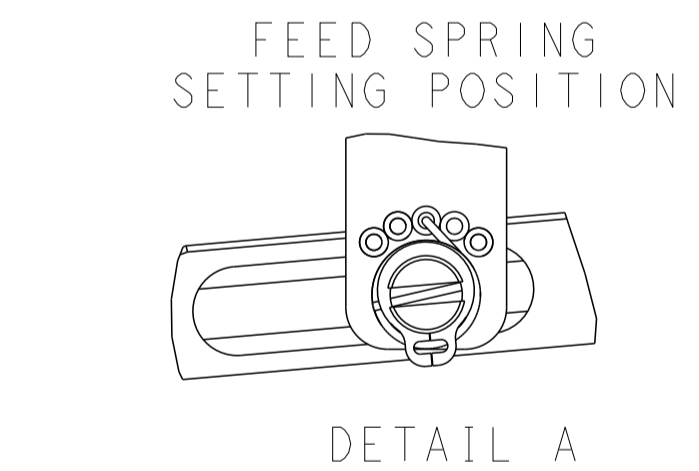
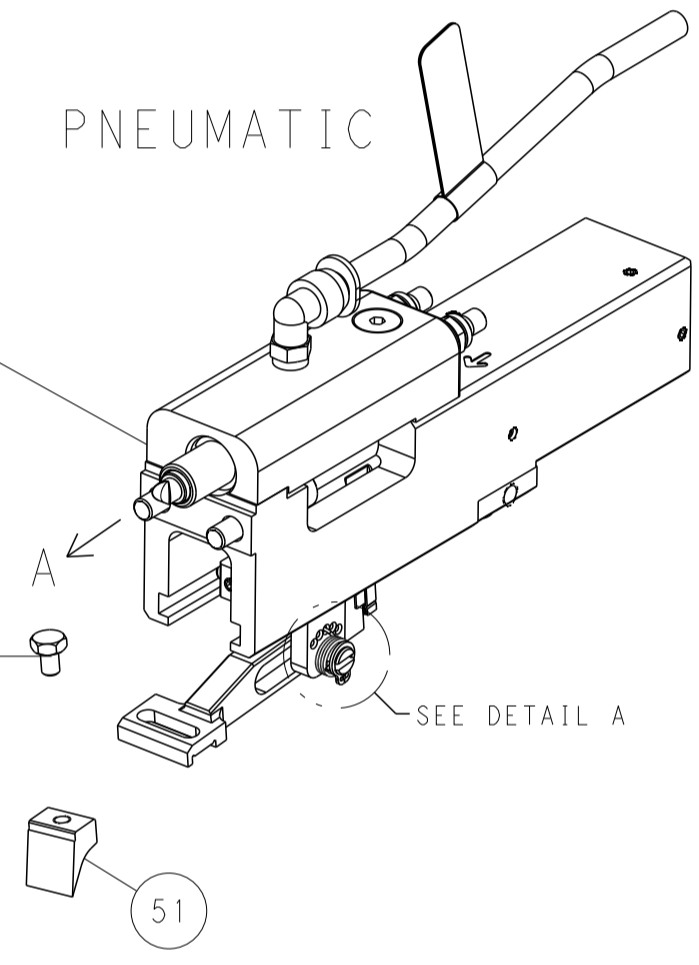
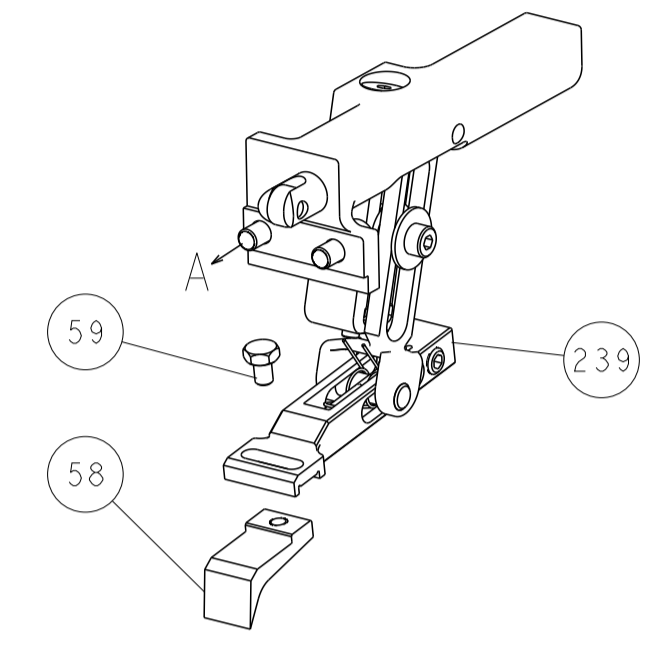

CAM POSITIONS

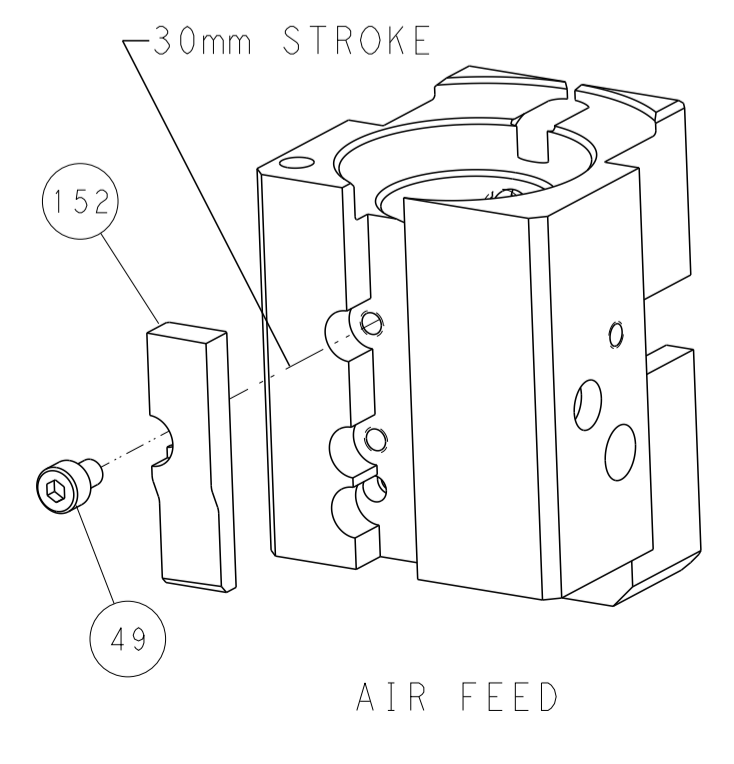
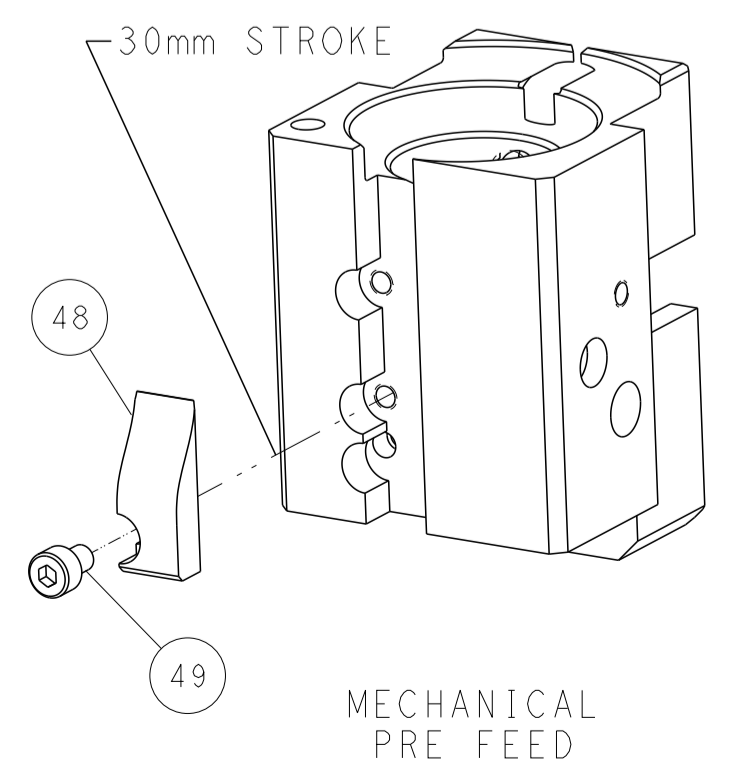
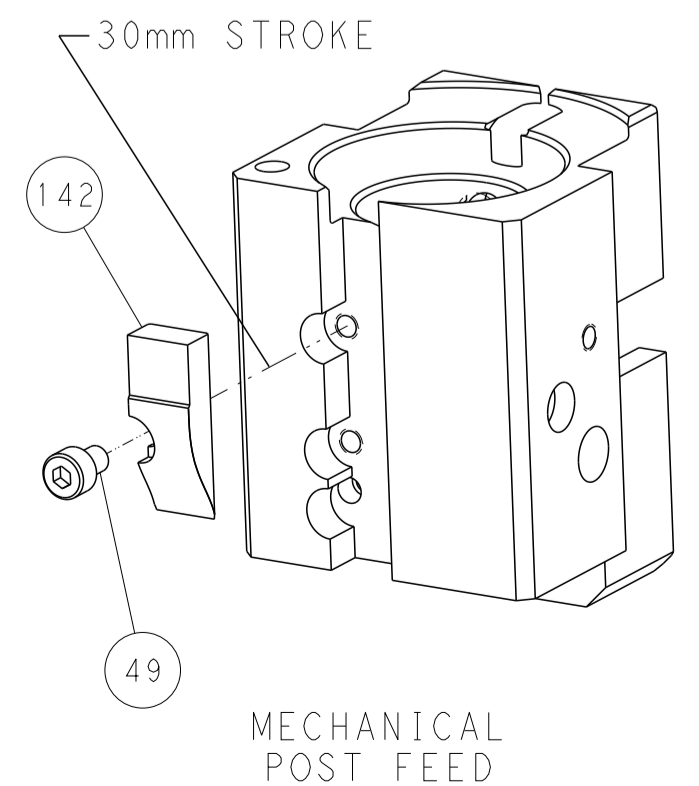

**PACIFIC VERSION**  
 Shown on sheets 3 of 4 & 4 of 4  
 (Atlantic version shown on sheets 1 of 4 & 2 of 4)

DIMENSIONS:		TOLERANCES UNLESS OTHERWISE SPECIFIED:		OWN: C. CHEN 14FEB2012		STE TE Connectivity Harrisburg, PA 17105-3608	
mm	0 PLC ±	1 PLC ±	2 PLC ±	3 PLC ±	4 PLC ±	APVD: S. XI 14FEB2012	NAME: Ocean End Feed Applicator
MATERIAL:	FINISH:	WEIGHT:	SCALE: 1:1	SHEET: 4	OF: 4	REV: G	RESTRICTED TO: