

## 1 The AS5043 adapter PCB:

The AS5043 adapter PCB is a simple circuit allowing customers to test and evaluate the AS5043 rotary encoder rapidly without having to build their own test fixture or PCB.

The PCB can be used as standalone unit or plugged onto the AS5043 demo board as external encoder. For Standalone operation, it can be supplied with 3.3V, 5V or 7.5...12V DC supply voltages.

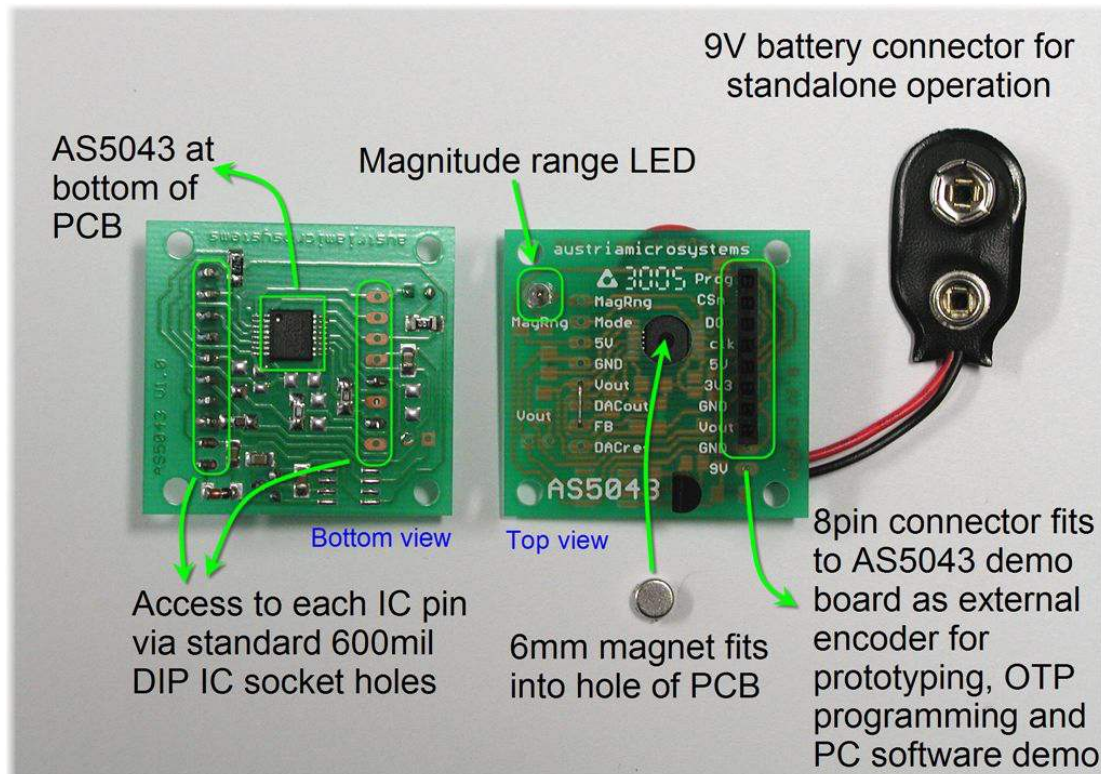

Figure 1: AS5043 Adapter PCB: top and bottom view

### Features:

- 100mil connector for direct connection to AS5043 demo board
- Provision for a 600mil DIP socket
- Hole in PCB to center a 6mm magnet at the bottom of the IC
- LED for MagRng output
- On-board 5V linear voltage regulator for 7.5...12V supplies
- 9V battery connector for standalone operation
- Dimensions: 35mm x 37mm (1.38 x 1.46 inch)

## 2 General Description

The AS5043 is a system-on-chip, combining integrated Hall elements, analog front end and digital signal processing in a single device. It provides incremental output signals and the absolute angular position of a magnet that is placed either above or below the device.

The AS5043 can be configured to specific customer requirements by programming the integrated OTP (one time programmable) register. An internal voltage regulator allows the AS5043 to operate at either 3.3 V or 5 V supplies.

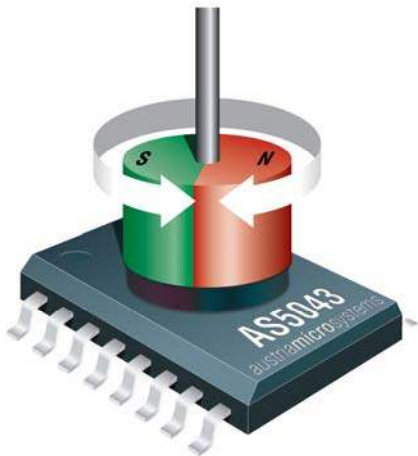

Figure 2: Typical arrangement AS5043 and magnet

## 3 Pin Configuration

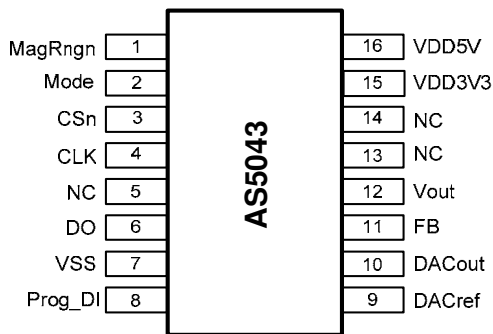

Figure 3: Pin configuration SSOP16

## 4 Pin Description

Pin	Symbol	Type	Description
1	MagRngn	DO_OD	Magnet Field Magnitude RaNGe warning; active low, indicates that the magnetic field strength is outside of the recommended limits.
2	Mode	DI_PD, ST	Mode input. Select between low noise (open, low) and high speed (high) mode. Internal pull-down resistor
3	CSn	DI_PU, ST	Chip Select, active low; Schmitt-Trigger input, internal pull-up resistor (~50kΩ)
4	CLK	DI,ST	Clock Input of Synchronous Serial Interface; Schmitt-Trigger input
5	NC	-	must be left unconnected
6	DO	DO_T	Data Output of Synchronous Serial Interface
7	VSS	S	Negative Supply Voltage (GND)
8	Prog_DI	DI_PD	OTP Programming Input and Data Input for Daisy Chain mode. Internal pull-down resistor (~74kΩ). Should be connected to VSS if not used
9	DACref	AI	DAC Reference voltage input for external reference
10	DACout	AO	DAC output (unbuffered, Ri ~8kΩ)
11	FB	AI	Feedback, OPAMP inverting input
12	Vout	AO	OPAMP output
13	NC	-	Must be left unconnected
14	NC	-	Must be left unconnected
15	VDD3V3	S	3V-Regulator Output for internal core, regulated from VDD5V. Connect to VDD5V for 3V supply voltage. Do not load externally.
16	VDD5V	S	Positive Supply Voltage, 3.0 to 5.5 V

Table 1: Pin description SSOP16

## 5 Principle of Operation

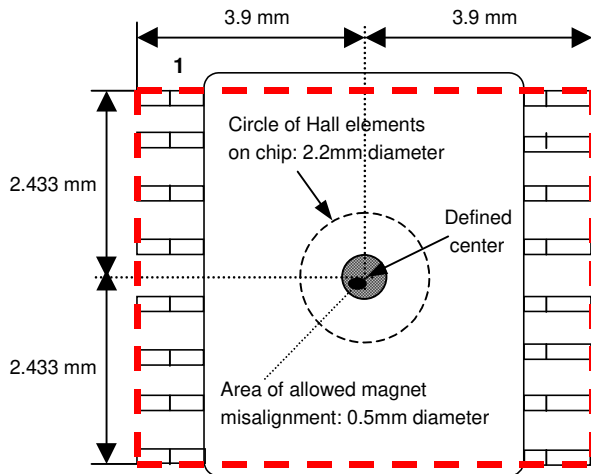

Figure 4: Tolerances of magnet placement

The AS5043 chip consists of a ring of hall elements, placed at the center of the IC at a circle diameter of 2.2mm (86.6mil).

The hall elements pick up the field of a magnet, placed atop this hall array circle. This information is digitized and fed into a digital signal processor (DSP), which calculates the angle of the magnet with a resolution of 0.0879 degrees or 4096 positions per revolution (10bit) at a sampling rate of 96 $\mu$ s (10kHz; Default) or 384 $\mu$ s (2.6kHz).

The digital angle information is available in several formats: as serial 10-bit data stream, as pulse-width modulated (PWM) signal or as quadrature incremental signal

### 5.1 Magnet considerations

A magnet, having one north / one south pole in the horizontal axis is placed right above the ring of hall elements (see Figure 2). The magnet does not necessarily need to be circular, it can be rectangular as well, as long as the north and south pole are arranged horizontally over the center of the hall array ring.

The magnetic field strength along this ring should be in the range of  $\pm 45 \dots 75$  milliTesla (mT).

#### 5.1.1 Magnet size

The size of the magnet should be at least the size of the hall array ring (2.2mm). Smaller magnets are more critical in terms of misalignment due to the non-linear magnetic field distribution along the circumference of the magnet. The recommended magnet diameter is 4...6mm

#### 5.1.2 Magnet distance and material

To achieve the required field strength at a reasonable distance (~0.5...5mm), it is recommended to use rare-earth magnets, such as Samarium-Cobalt (SmCo) or Neodyme-Iron-Boron (NdFeB) magnets.

#### 5.1.3 Magnet misalignment

In theory, the magnet misalignment is not critical for this type of angular measurement. In practice however, magnets are not perfectly linear. The magnetic field strength does not increase linearly with the radius. As you get towards the boundary of the magnet, the magnetic field comes to a maximum and then weakens as you move further away from the center. Therefore, a magnet should be chosen, that is still in the linear range at a <3mm diameter.

#### 5.1.4 Non-linearity errors

A non-linear magnetic field results in a non-sinusoidal representation of the magnet, which in turn causes non-linearities in the calculated angle (calculated angle differs from actual angle).

With a perfectly centered magnet, the maximum error is  $< \pm 0,5$  degrees. This error is caused by internal mismatch and gain errors.

With the recommended 4mm magnet (Bomatec BMN-35H), the maximum error of  $< \pm 1.4$  degrees (including internal errors and temperature related errors) can be achieved while the magnet is off-center by a radius of <0.25mm (see Figure 4).

## 6 AS5043 Adapter PCB Schematic:

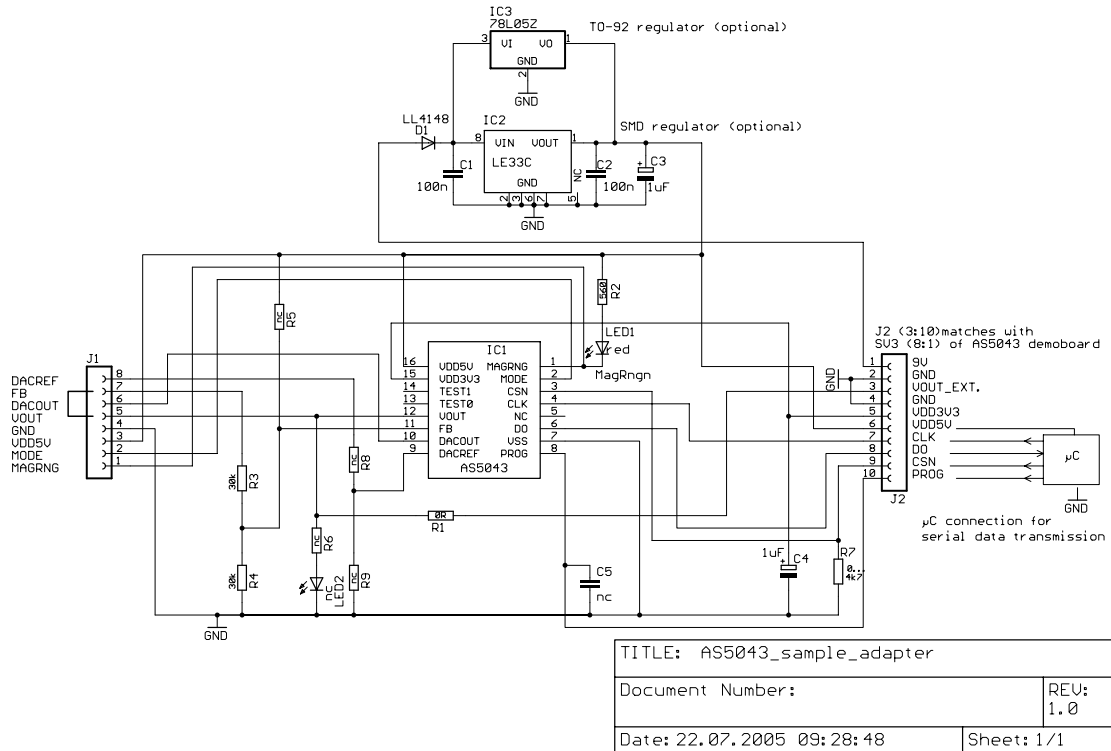

Figure 5: AS5043 Adapter PCB schematic

For normal operation, the only required external components are the buffer cap at VDD3V3 (C4) and the pull-down resistor for CSn (R7; 0Ω....4k7).

The PCB operates at several power supply levels:

Power Supply options:

Supply voltage	apply at	ext. voltage regulator IC2 or IC3	digital I/O level	remark
3,0....3,6V	VDD5V and VDD3V3	not required *)	3.0....3.6V	short VDD5V and VDD3V3
4,5....5,5V	VDD5V	not required *)	4.5....5.5V	
7,5...20V	ext. voltage regulator (pin 1, J2)	3.3V type, e.g. LE33C (ST Micro)	3.3V	short VDD5V and VDD3V3
7,5...20V	ext. voltage regulator (pin 1, J2)	5.0V type e.g. 75L05	5.0V	PCB delivery status

\*) if already installed, external voltage regulator can be left installed.

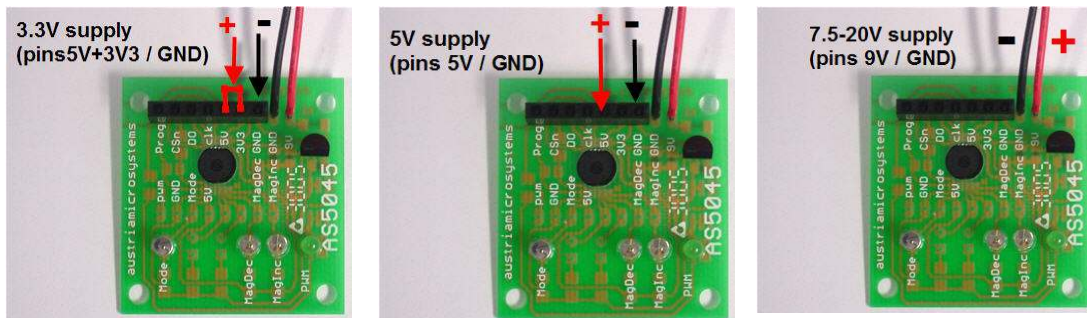

Figure 6: how to connect various power supply levels to the adapter PCB

Output modes:

- Absolute angle information  
 To access the 10-bit absolute angle information, an external microcontroller must be connected as shown in Figure 5. Make sure that the controller is able to drive the CSn pin with the connected pulldown resistor (R7). If necessary, remove this resistor.  
 The clock rate can be as high as 1MHz. There is no minimum clock rate. Data can also be clocked manually.  
 The digital I/O's of the AS5043 are buffered by VDD5V, therefore the digital I/O's of the controller should be at the same voltage level (see power supply options table).
- Analog output  
 No additional components are required. The voltage at the Vout pin (pins 3 of J1) indicates the position of the encoder. (see datasheet).

Programming (zapping) the Chip.

For programming the AS5043, 3 digital signals are required: CSn, Prog and CLK (see datasheet). For permanent writing, VPROG must be elevated to 7.5V during the programming cycle.

For immediate programming, this PCB can be connected directly to the AS5043 demo board (available separately), where all the programming timings are generated by the onboard microcontroller.

AS5043 adapter PCB layout and component placement:

The PCB has several connection options. All required pins are accessible via the two 100mil- connectors J1 and J2.

These connectors are 600mil apart, which allows them to be soldered to a wide 16-pin DIL IC socket for easier access or ribbon cable connection.

Furthermore, J2 (pins 3..9) fit to the AS5043 demo board and allow this PCB to be used as external encoder.

The hole in the PCB underneath the chip allows centering of a 6mm diameter magnet.

A Vout Led and voltage regulators are optional. Minimum required components are C4 (1µF) and the CSN pull-down R7 (0...4k7).

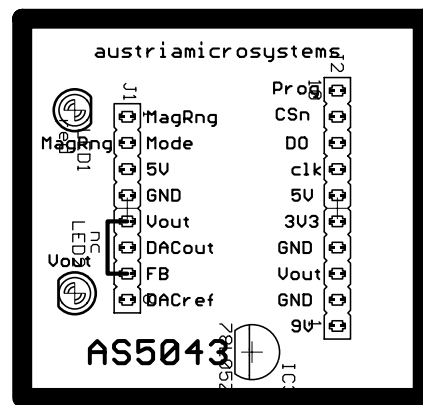

AS5043 adapter board: top view

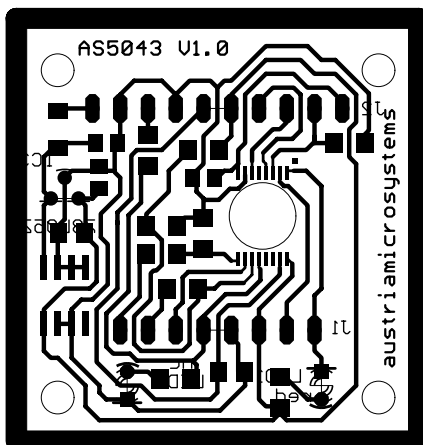

Layout: Bottom View

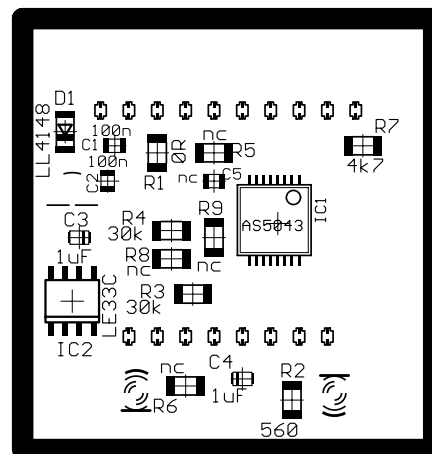

Layout: Bottom Components

AS5043 adapter PCB dimensions:

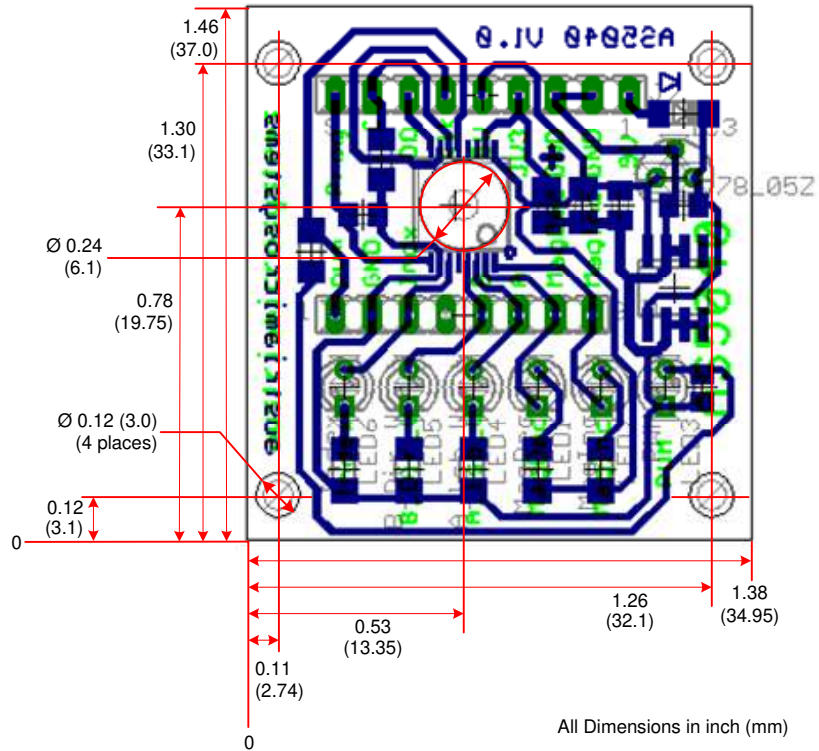

Figure 7: AS5043 adapter board dimensions.

## 7 Supporting tools

[austriamicrosystems](http://www.austriamicrosystems.com) provides the following tools for developments using the AS5043 rotary encoder IC:

AS5043 Demoboard (see Figure 8)

AS5043 Demoboard Operation Manual

AS5043 Demoboard Software

AS5043 Adapter PCB (see Figure 1)

These supporting tools are available at local distributors

[http://www.austriamicrosystems.com/06contactcenter/sales\\_start.htm](http://www.austriamicrosystems.com/06contactcenter/sales_start.htm)

or can be ordered online:

[http://www.austriamicrosystems.com/03products/products\\_detail/AS5043/description\\_AS5043.htm](http://www.austriamicrosystems.com/03products/products_detail/AS5043/description_AS5043.htm)

## 8 AS5043 Demoboard

The AS5043 Demoboard is a complete rotary encoder system with built-in microcontroller, USB interface, 4-digit 7-segment display and a LED displaying the magnitude range.

It also supports external AS5043 applications, such as the AS5043 adapter PCB or in-system AS5043 customer applications that can be connected to the demoboard and displayed, modified and permanently programmed using the AS5043 Demoboard Software.

The AS5043 demoboard can be used in several ways:

### 8.1.1 as standalone unit supplied by a 9V-battery

Connect a 7.5V..12V supply to pins "GND" and "+9V" at the right side of the board. No other connections are required

### 8.1.2 as standalone unit supplied by an USB port

Connect the demoboard to a PC using a USB cable (included in demoboard shipment). The board is supplied by the 5V supply of the USB port. No other connections are required

### 8.1.3 as input device for the AS5043 demoboard software

This configuration uses the same hardware connection as 8.1.2, but additionally the AS5043 demoboard software is running. All indicators on the demoboard will be displayed on the PC screen as well.

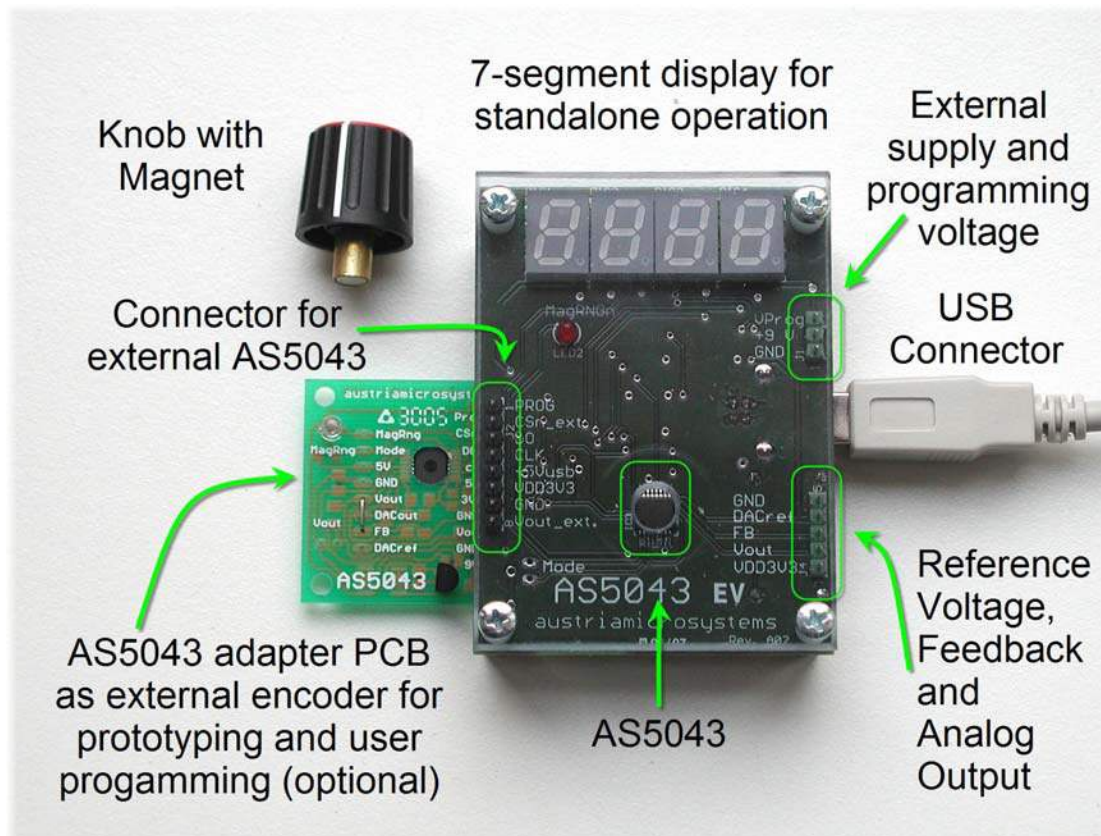

Figure 8: AS5043 demoboard and Adapter PCB

## 9 AS5043 Demoboard Software

The AS5043 Demoboard Software can be downloaded for free from the Internet at:

[http://www.austriamicrosystems.com/03products/products\\_detail/AS5043/download\\_AS5043.htm?#software](http://www.austriamicrosystems.com/03products/products_detail/AS5043/download_AS5043.htm?#software)

It has several indicators and extra features, such as:

- Displaying the absolute angle as 10bit-word (0..1023), as absolute degrees (0..360) and as rotary dial
- Displaying the analog voltage output
- Displaying the status and diagnostic bits (magnitude ranges) of the AS5043
- Programming the zero position (OTP)
- Programming clockwise or counterclockwise operation
- Putting the AS5043 in alignment mode to aid centering the magnet over the IC.

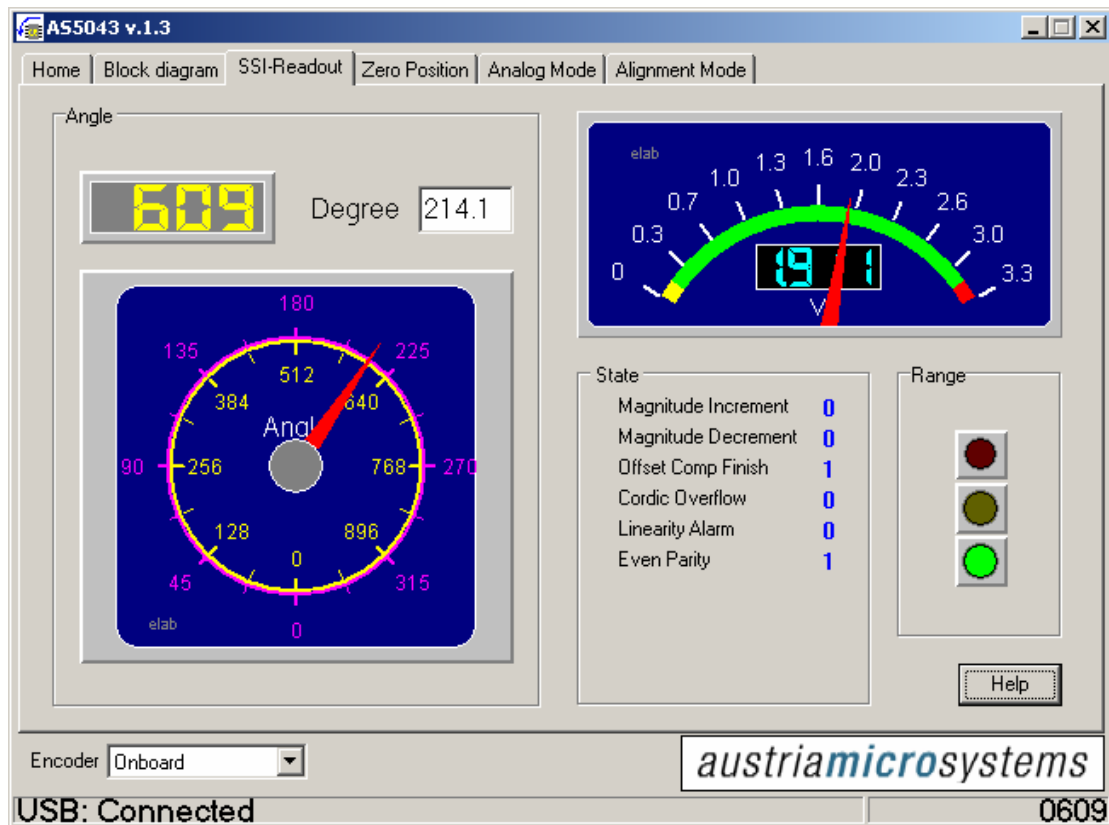

Further information on the AS5043 Demoboard Software is available in the AS5043 Demoboard Operation Manual (see: 7 Supporting tools)

### 9.1 Connecting the AS5043 adapter PCB to the demoboard

The AS5043 Adapter PCB is intended as a standalone device that allows easy and quick testing of the AS5043 without the need of having to make your own PCB.

It allows access to each IC pin via a standard 100mil pitch, 600mil Dual-In-Line connector, has LEDs on all digital outputs and comes with an onboard 5V linear voltage regulator (78L05) and a battery clip to supply the board from a 9V battery.

The 8-pin female connector is designed to fit directly onto the AS5043 Demoboard and use the Adapter PCB as external encoder (software setting: Encoder = external).

The demoboard however, runs at 3.3V supply voltage. The Adapter PCB is configured for 5V supply voltage. Connecting both boards without modifications will not harm any of the boards, but may lead to data transmission errors due to the different digital levels, especially when an extension cable is used between demoboard and Adapter PCB.



If you use the Adapter PCB as external encoder for the AS5043 demoboard with an extension cable or experience data transmission errors, it is requested to configure the Adapter PCB for 3.3V supply voltage.

9.1.1 Modifications to operate the adapter board at 3.3V

Perform the following modifications:

- disconnect the 5V supply between Demoboard and Adapter PCB: remove or cut off pin "+5VUSB" at the bottom of the AS5043 demoboard
- connect pins "3V3" and "5V" on the Adapter PCB. Ideally, connect the pins right at the bottom of the 7pin female connector with a piece of wire or solder joint.
- you may also remove the 78L05 voltage regulator from the Adapter PCB to prevent accidental damage of the IC when an input voltage is applied to the regulator (and the 5V output is fed to the VDD3V3 supply pin)

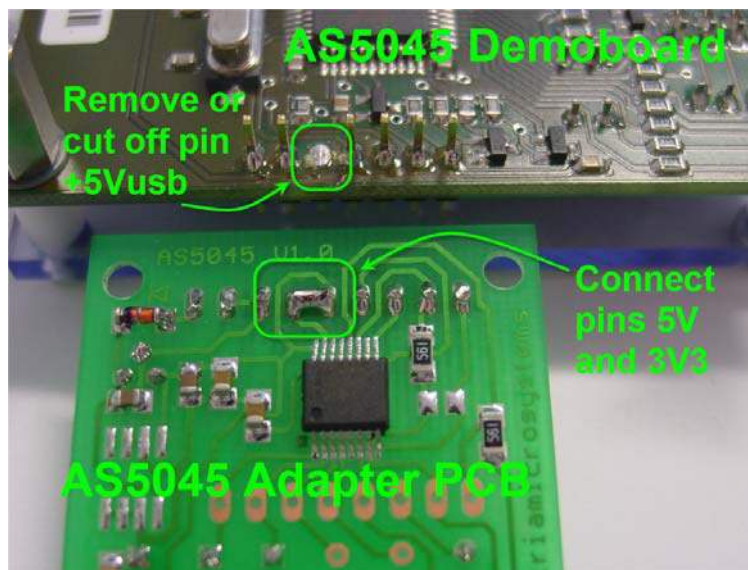

Figure 9: Configuring the Adapter PCB for 3.3V operation (See Figure 10)

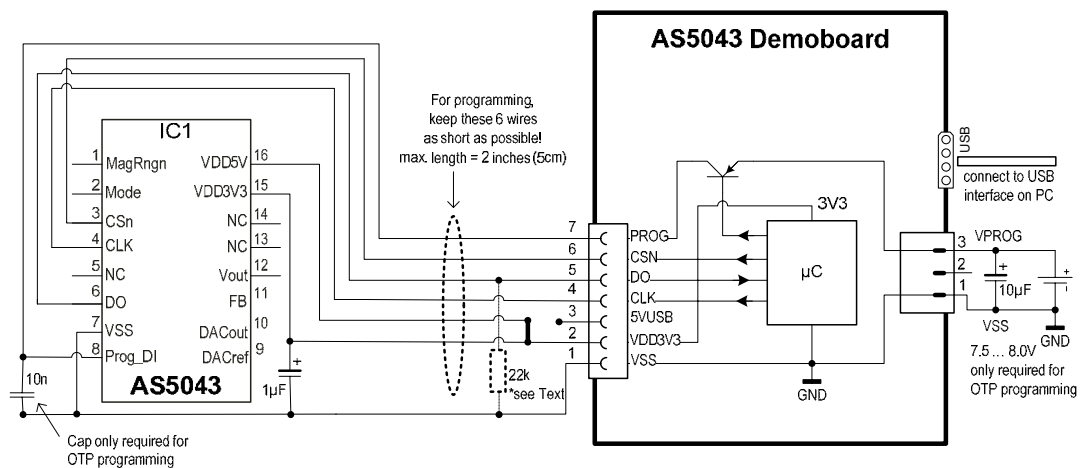

Figure 10: Connecting an external AS5043 application to the demoboard (See Figure 9)

\* If longer cables are used, a pull-down resistor at the DO line of 22k - 56k Ohms is recommended to discharge the signal between data transmissions and no static voltage is built up.

## 9.2 Reading the Adapter PCB with the AS5043 Demoboard Software:

Further information on the AS5043 Demoboard Software is available in the AS5043 Demoboard Operation Manual (see: 7 Supporting tools)

The AS5043 Adapter PCB can be read as "external encoder" in the same way as the internal encoder. Switching from internal to external encoder can be done on the bottom left corner of the demoboard software screen: Encoder = onboard / external. Additionally, when Encoder = external is selected, the buttons "Permanent write" and "Read" are enabled in the "Zero Position" and "Incremental Mode" screens to allow OTP programming of the external encoder

### Changing the Zero Position:

The programming options zero position and CCW operation can be modified at any time during normal operation. Permanently programming these registers will set the default setting after power-up. Programmed settings can again be modified during normal operation but will be reset to default when the power supply is disconnected.

### OTP programming of the external AS5043 encoder:

To program the external AS5043 encoder, a programming voltage of 7.5 to 8V DC (130mA) must be applied to pins Vzapp and GND of the 3-pin connector at the right hand side of the demoboard. A 10 $\mu$ F buffer cap is recommended for this voltage (see Figure 10).

Programming is not recommended with long wires between demoboard and external encoder, as the inductance of the cable may generate high voltage spikes, that can cause wrong programming or even harm the IC. The maximum wire length between the demoboard connector and the PROG pin of the external encoder should be 50mm (2"). Additionally, a 10nF ceramic capacitor should be connected close to pin PROG and VSS.

An OTP (one time programming) cycle is automatically initiated, when button "Permanent write" is pressed. The default (non-programmed) logic state is "0" , consequently the programmed logic state is "1". It is possible to write "1"s into the OTP register at subsequent programming cycles. However, a programmed "1" cannot be cleared any more after programming.

Note that the chip will not be programmed, as long as no programming voltage is applied to Vzapp, although the software will issue a warning message that the chip will be permanently programmed.

## 10 Contact

### Headquarters

austriamicrosystems AG  
A 8141 Schloss Premstätten, Austria  
Phone: +43 3136 500 0  
Fax: +43 3136 525 01  
[industry.medical@austriamicrosystems.com](mailto:industry.medical@austriamicrosystems.com)  
[www.austriamicrosystems.com](http://www.austriamicrosystems.com)

### 10.1 Sales Offices

austriamicrosystems Germany GmbH  
Tegernseer Landstrasse 85  
D-81539 München, Germany  
Phone: +49 89 69 36 43 0  
Fax: +49 89 69 36 43 66

austriamicrosystems Italy S.r.l.  
Via A. Volta, 18  
I-20094 Corsico (MI), Italy  
Phone: +39 02 4586 4364  
Fax: +39 02 4585 773

austriamicrosystems France S.A.R.L.  
124, Avenue de Paris  
F-94300 Vincennes, France  
Phone: +33 1 43 74 00 90  
Fax: +33 1 43 74 20 98

austriamicrosystems Switzerland AG  
Rietstrasse 4  
CH 8640 Rapperswil, Switzerland  
Phone: +41 55 220 9008  
Fax: +41 55 220 9001

austriamicrosystems UK, Ltd.  
88, Barkham Ride,  
Finchampstead, Wokingham  
Berkshire RG40 4ET, United Kingdom  
Phone: +44 118 973 1797  
Fax: +44 118 973 5117

austriamicrosystems AG  
Klaavuntie 9 G 55  
FI 00910 Helsinki, Finland  
Phone: +358 9 72688 170  
Fax: +358 9 72688 171

austriamicrosystems AG  
Bivågen 3B  
S 19163 Sollentuna, Sweden  
Phone: +46 8 6231 710

austriamicrosystems USA, Inc.  
8601 Six Forks Road  
Suite 400  
Raleigh, NC 27615, USA  
Phone: +1 919 676 5292  
Fax: +1 509 696 2713

austriamicrosystems USA, Inc.  
4030 Moorpark Ave  
Suite 116  
San Jose, CA 95117, USA  
Phone: +1 408 345 1790  
Fax: +1 509 696 2713

austriamicrosystems AG  
Suite 811, Tsimshatsui Centre  
East Wing, 66 Mody Road  
Tsim Sha Tsui East, Kowloon, Hong Kong  
Phone: +852 2268 6899  
Fax: +852 2268 6799

austriamicrosystems AG  
AIOS Gotanda Annex 5<sup>th</sup> Fl., 1-7-11,  
Higashi-Gotanda, Shinagawa-ku  
Tokyo 141-0022, Japan  
Phone: +81 3 5792 4975  
Fax: +81 3 5792 4976

austriamicrosystems AG  
#805, Dong Kyung Bldg.,  
824-19, Yeok Sam Dong,  
Kang Nam Gu, Seoul  
Korea 135-080  
Phone: +82 2 557 8776  
Fax: +82 2 569 9823

austriamicrosystems AG  
Singapore Representative Office  
83 Clemenceau Avenue, #02-01 UE Square  
239920, Singapore  
Phone: +65 68 30 83 05  
Fax: +65 62 34 31 20

## 11 Revision History

Revision	Date	Description
A01	Jan. 16, 2006	Creation
	Apr. 06, 2006	Updates of SW images
A02	Jul. 04, 2006	Figure 7: AS5043 adapter board dimensions.

## 12 Copyright

Devices sold by austriamicrosystems are covered by the warranty and patent indemnification provisions appearing in its Term of Sale. austriamicrosystems makes no warranty, express, statutory, implied, or by description regarding the information set forth herein or regarding the freedom of the described devices from patent infringement. austriamicrosystems reserves the right to change specifications and prices at any time and without notice. Therefore, prior to designing this product into a system, it is necessary to check with austriamicrosystems for current information. This product is intended for use in normal commercial applications.

Copyright © 2006 austriamicrosystems. Trademarks registered ®. All rights reserved. The material herein may not be reproduced, adapted, merged, translated, stored, or used without the prior written consent of the copyright owner. To the best of its knowledge, austriamicrosystems asserts that the information contained in this publication is accurate and correct. However, austriamicrosystems shall not be liable to recipient or any third party for any damages, including but not limited to personal injury, property damage, loss of profits, loss of use, interruption of business or indirect, special, incidental or consequential damages, of any kind, in connection with or arising out of the furnishing, performance or use of the technical data herein. No obligation or liability to recipient or any third party shall arise or flow out of austriamicrosystems rendering of technical or other services.

*austriamicrosystems*

a leap ahead