

**NOTES**

- 本製品は極数によって、ロック形状が変わりますので御注意願います。  
THE LOCK SHAPE OF THIS PRODUCT CHANGES ACCORDING TO THE NUMBER OF CIRCUIT.  
2~5 CIRCUITS : フリクションロック FRICTION LOCK  
6~15 CIRCUITS : インナーポジティブロック INNER POSITIVE LOCK
- 材料及び仕上げ(めっき仕様) : TABLE 1,2 参照  
MATERIAL AND FINISHES : SEE TABLE 1 AND 2
- 製品仕様書 : 5013300000-PS PS 004  
PRODUCT SPECIFICATION:
- 梱包形態 : SEE SHEET 4  
PACKAGING INFORMATION:
- 嵌合相手 : 501330 シリーズ  
MATES WITH:501330 SERIES
- アプリケーション仕様書(コネクタ取扱い説明書) : 5013300000-AS PS 001  
APPLICATION SPECIFICATION(CONNECTOR MANUAL):
- ソルダーピン及びネイルの平坦度:0.1 MAX  
SOLDER PIN AND NAIL COPLANARITY: 0.1 MAX
- 偶数極に適用  
APPLY FOR EVEN CIRCUIT
- 錫めっき品は2083810000-SD PSD 001の図面を御参照下さい。  
PLEASE REFER TO THE DRAWING OF 2083810000-SD PSD 001 FOR TIN PLATING VERSION.

△10 製品番号構成 : 発注番号はSHEET 6 参照  
PRODUCT NUMBER COMPOSITION  
ORDER No. : SEE SHEET 6

**208381** \* \* \* \*

極数 CIRCUIT SIZE	ハウジングカラー HOUSING COLOR	製品識別番号(めっき厚) IDENTIFICATION NUMBER (PLATING THICKNESS)
	0:NATURAL(BEIGE)	7: 0.1 MICRO-METER MIN
	1:BLACK	5: 0.38 MICRO-METER MIN
		3: 0.76 MICRO-METER MIN

4.0	7.0	5
3.0	6.0	4
2.0	5.0	3
1.0	4.0	2
B	A	極数 CIRCUIT SIZE

△2 TABLE 1

番号 NO.	部品 PART	材質 MATERIAL	
①	ウエハー WAFER	ポリアミド(PA), ガラス充填, UL94V-0, LOW HALOGEN, 色 : SEE SHEET 6 POLYAMIDE(PA), GLASS FILLED, UL94V-0, LOW HALOGEN, COLOR : SEE SHEET 6	
②	ソルダーピン SOLDER PIN	リン青銅 PHOSPHOR BRONZE	
		接点部 CONTACT AREA	金めっき : めっき厚はNOTES 10参照 GOLD PLATING : SEE NOTES 10 ABOUT THICKNESS
		テール部 TAIL AREA	金めっき GOLD PLATING
③	ネイル NAIL	下地めっき UNDER PLATING	ニッケルめっき : 1.0 MICRO-METER MIN NICKEL PLATING
		テール部 TAIL AREA	錫めっき : 1.0 MICRO-METER MIN MATTE TIN PLATING
④	カバーテープ COVER TAPE	下地めっき UNDER PLATING	ニッケルめっき : 1.0 MICRO-METER MIN NICKEL PLATING
		ポリイミドテープ POLYIMIDE TAPE	

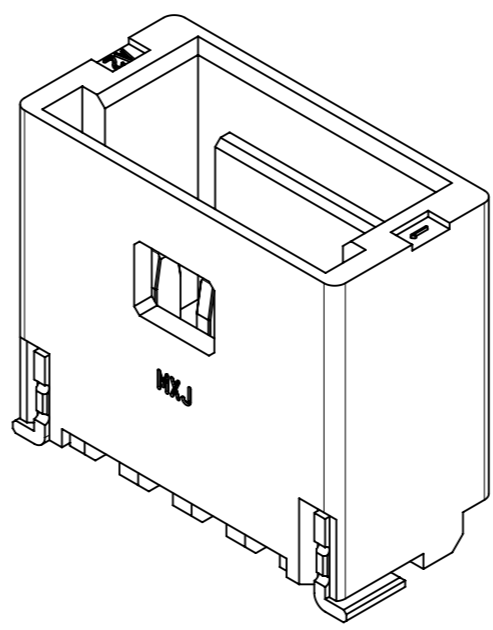

THIS DRAWING CONTAINS INFORMATION THAT IS PROPRIETARY TO MOLEX ELECTRONIC TECHNOLOGIES, LLC AND SHOULD NOT BE USED WITHOUT WRITTEN PERMISSION		CURRENT REV DESC:		<b>molex</b>	
DIMENSION UNITS	SCALE	EC NO: 626442			
mm	NTS	DRWN: AISHIKAWA 2019/06/21		PICO-CLASP 1.0 W/B	
GENERAL TOLERANCES (UNLESS SPECIFIED)		CHK'D: AIDA 2019/12/25		SINGLE ROW VT SMT INNER LOCK GOLD PLATING	
ANGULAR TOL	± 3.0°	APPR: SAKIYAMA 2019/12/25		LOW HALOGEN	
4 PLACES	± 0.2	INITIAL REVISION:		PRODUCT CUSTOMER DRAWING	
3 PLACES	± 0.2	DRWN: AISHIKAWA 2019/06/21		DOCUMENT NUMBER	
2 PLACES	± 0.2	APPR: SAKIYAMA 2019/12/25		2083810000-SD	
1 PLACE	± 0.2	DRAFT WHERE APPLICABLE MUST REMAIN WITHIN DIMENSIONS		PSD 000 A	
0 PLACES	± 0.2	THIRD ANGLE PROJECTION		DOC TYPE DOC PART REVISION	
		DRAWING SERIES		CUSTOMER SHEET NUMBER	
		A3-SIZE 208381		SEE SHEET 6 1 OF 6	

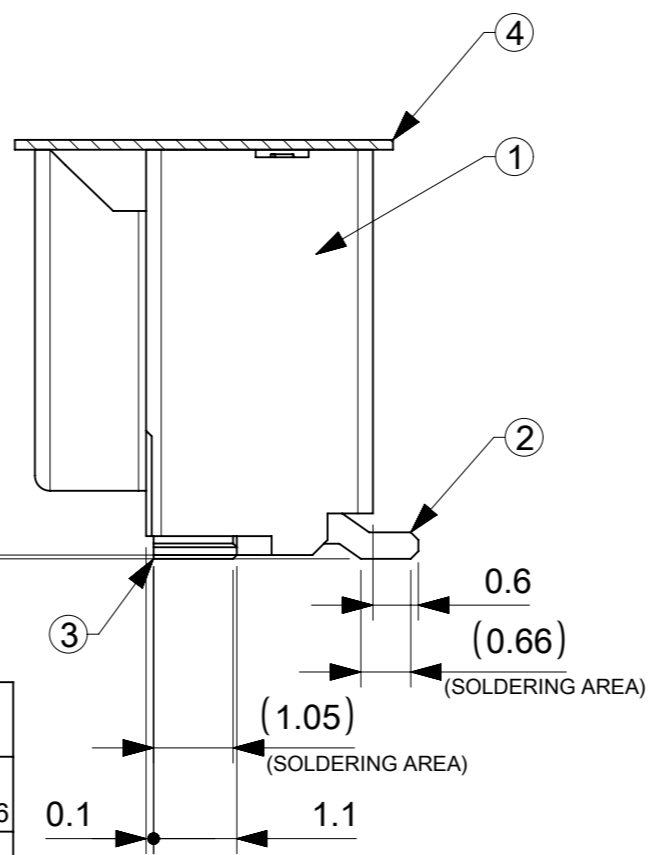
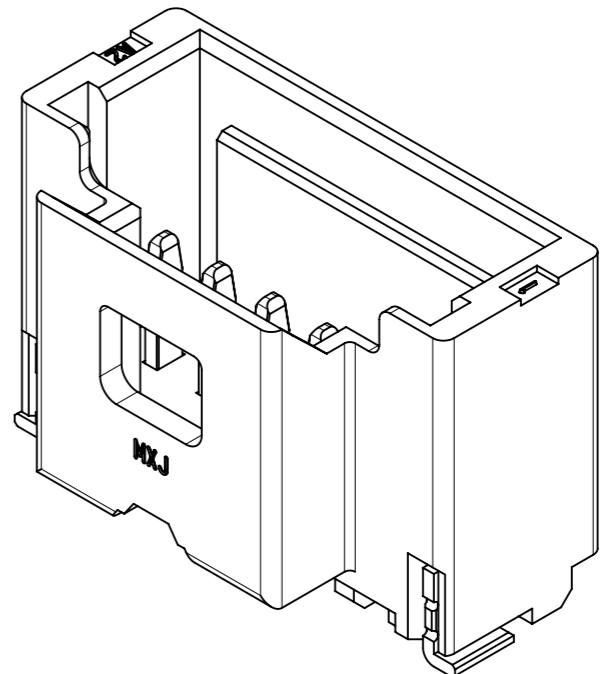
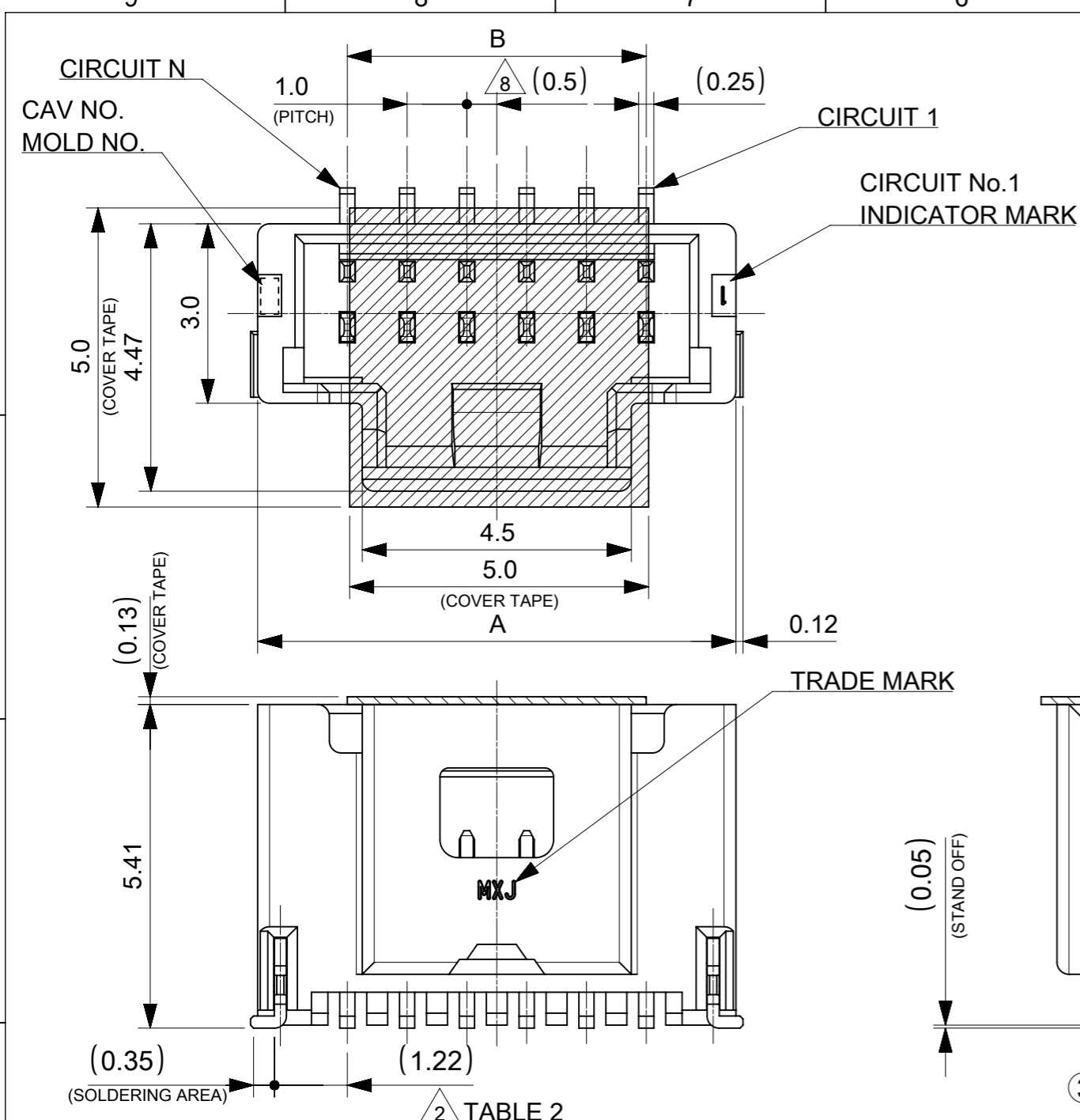

番号 NO.	部品 PART	材質 MATERIAL	
①	ウエハー WAFER	ポリアミド(PA), ガラス充填, UL94V-0, LOW HALOGEN, 色 : SEE SHEET 6 POLYAMIDE(PA), GLASS FILLED, UL94V-0, LOW HALOGEN, COLOR : SEE SHEET 6	
②	ソルダーピン SOLDER PIN	リン青銅 PHOSPHOR BRONZE	
		接点部 CONTACT AREA	金めっき : めっき厚はNOTES 10参照 GOLD PLATING : SEE NOTES 10 ABOUT THICKNESS
		テール部 TAIL AREA	金めっき GOLD PLATING
③	ネイル NAIL	下地めっき UNDER PLATING	ニッケルめっき : 1.0 MICRO-METER MIN NICKEL PLATING
		テール部 TAIL AREA	錫めっき : 1.0 MICRO-METER MIN MATTE TIN PLATING
④	カバーテープ COVER TAPE	ポリイミドテープ POLYIMIDE TAPE	

DOCUMENT STATUS	P1	RELEASE DATE	2019/12/25	07:30:31
-----------------	----	--------------	------------	----------

14.0	17.0	15
13.0	16.0	14
12.0	15.0	13
11.0	14.0	12
10.0	13.0	11
9.0	12.0	10
8.0	11.0	9
7.0	10.0	8
6.0	9.0	7
5.0	8.0	6
B	A	極数 CIRCUIT SIZE

THIS DRAWING CONTAINS INFORMATION THAT IS PROPRIETARY TO MOLEX ELECTRONIC TECHNOLOGIES, LLC AND SHOULD NOT BE USED WITHOUT WRITTEN PERMISSION

DIMENSION UNITS	SCALE	CURRENT REV DESC:	<b>molex</b>		
mm	NTS				
GENERAL TOLERANCES (UNLESS SPECIFIED)			PICO-CLASP 1.0 W/B		
ANGULAR TOL	± 3.0 °	EC NO: 626442	SINGLE ROW VT SMT INNER LOCK GOLD PLATING		
4 PLACES	± 0.2	DRWN: AISHIKAWA 2019/06/21	LOW HALOGEN		
3 PLACES	± 0.2	CHK'D: AIDA 2019/12/25	PRODUCT CUSTOMER DRAWING		
2 PLACES	± 0.2	APPR: SAKIYAMA 2019/12/25	DOCUMENT NUMBER		
1 PLACE	± 0.2	INITIAL REVISION:	DOC TYPE		
0 PLACES	± 0.2	DRWN: AISHIKAWA 2019/06/21	DOC PART		
DRAFT WHERE APPLICABLE MUST REMAIN WITHIN DIMENSIONS			REVISION		
THIRD ANGLE PROJECTION			2083810000-SD		
DRAWING			PSD		
SERIES			000		
MATERIAL NUMBER			A		
CUSTOMER			SEE SHEET 6		
SHEET NUMBER			2 OF 6		

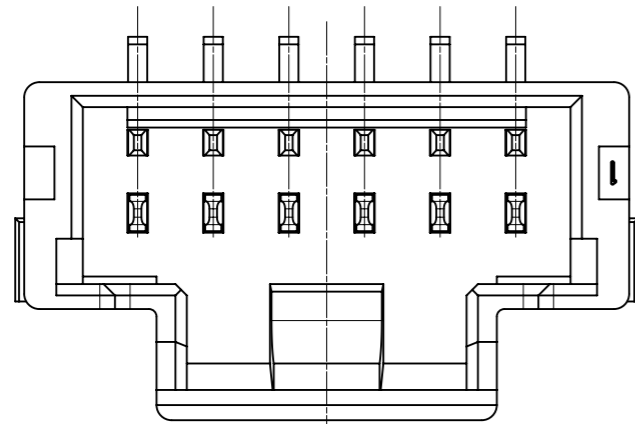

製品レイアウト(参考: 6~15 CIRCUITS)  
PRODUCT LAYOUT(REFERENCE: 6~15 CIRCUITS)

△ 嵌合相手: 501330 シリーズ  
MATE WITH: 501330 SERIES

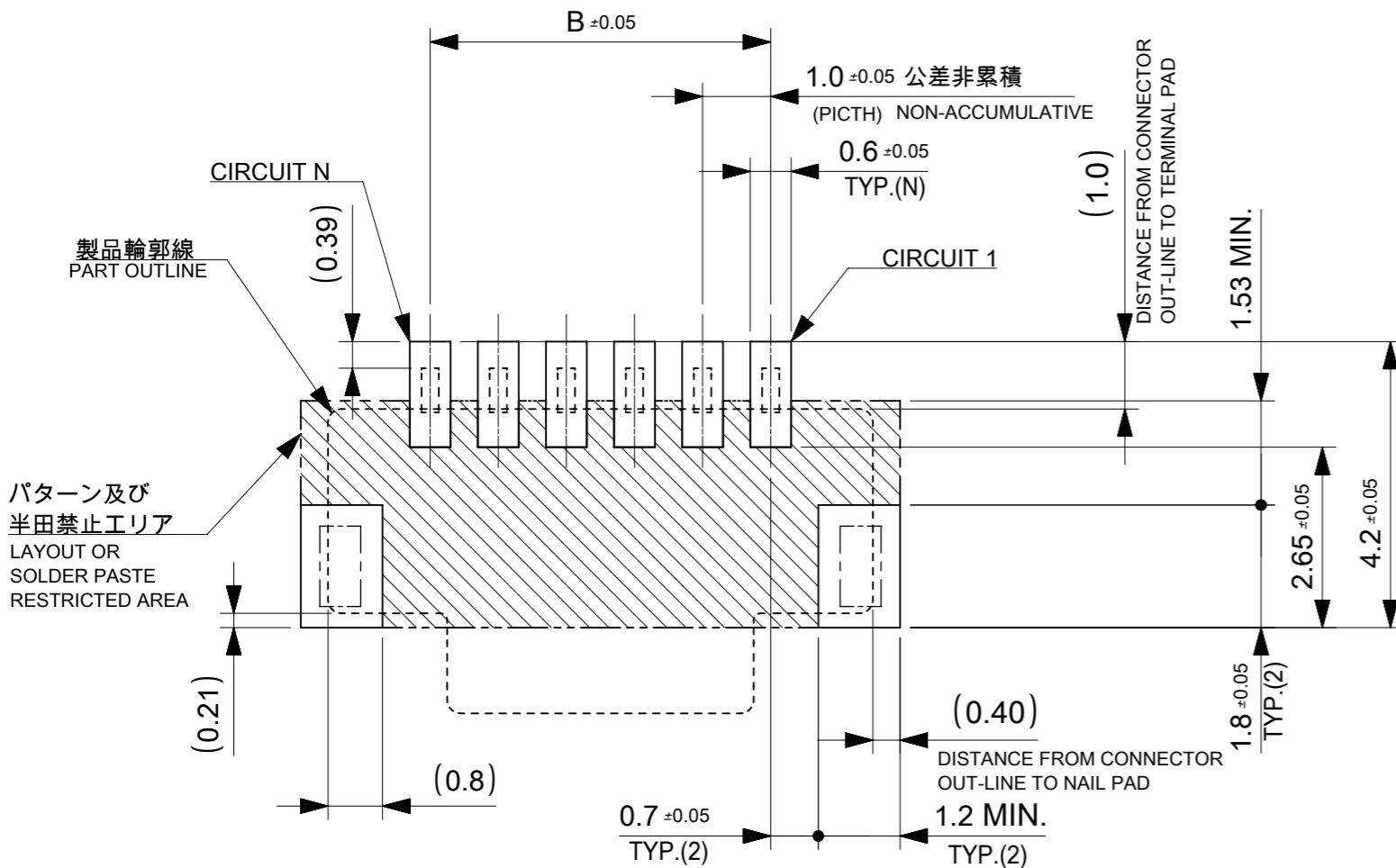

推奨基板レイアウト(全極数適応): 実装面側  
(参考: 基板厚 1.0mm, メタルマスク厚さ 0.12mm, マスク開口率100%)

POLARIZED RECOMMENDED PCB LAYOUT(APPLY TO ALL CIRCUIT): COMPONENT SIDE  
(REFERENCE: PCB THICKNESS 1.0mm, STENCIL THICKNESS 0.12mm, APERTURE RATIO 100%)

:パターン禁止エリア  
RESTRICTED AREA  
NO PCB COMPONENTS ALLOWED

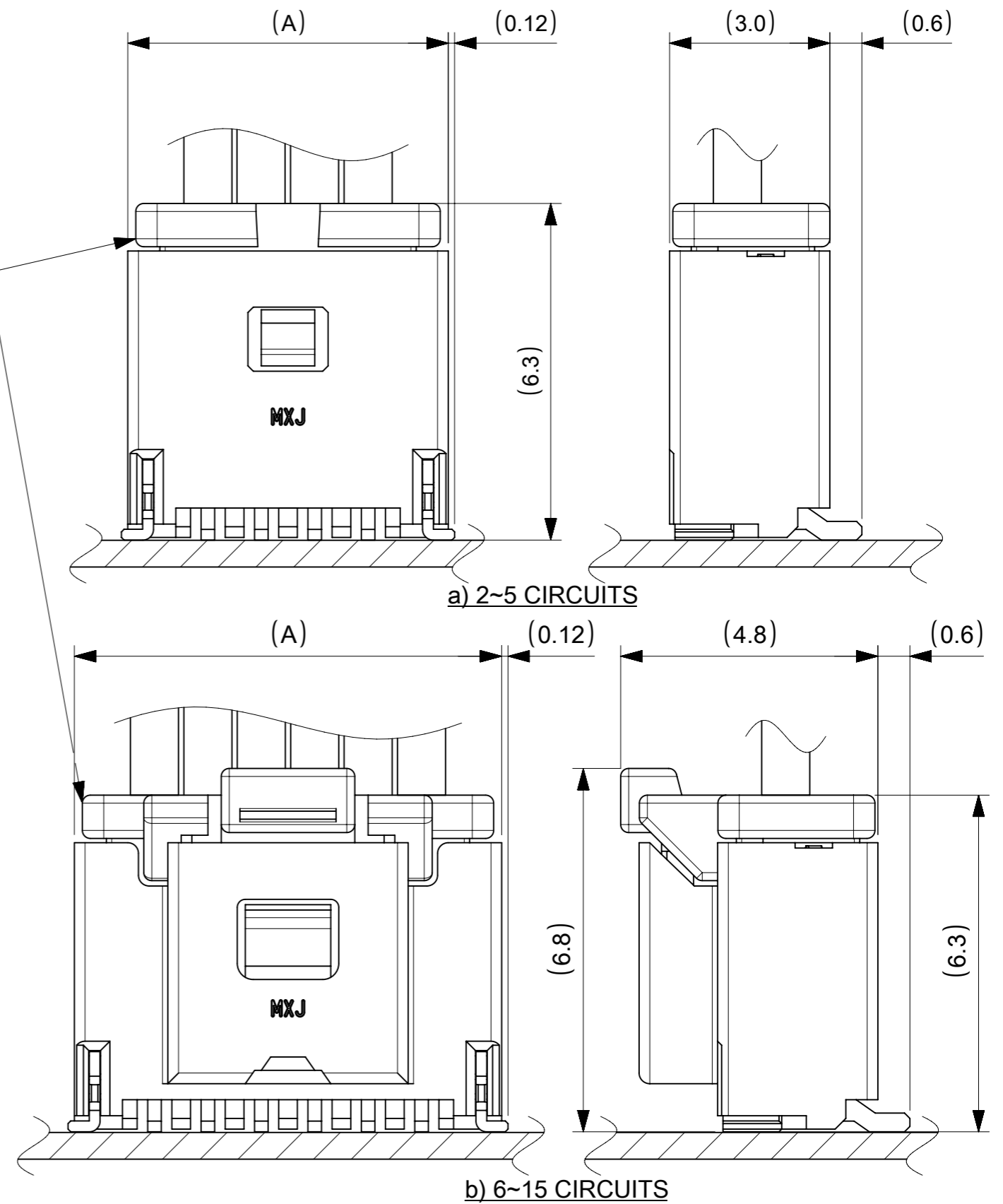

嵌合図  
MATED CONNECTORS

THIS DRAWING CONTAINS INFORMATION THAT IS PROPRIETARY TO MOLEX ELECTRONIC TECHNOLOGIES, LLC AND SHOULD NOT BE USED WITHOUT WRITTEN PERMISSION		CURRENT REV DESC:			
DIMENSION UNITS	SCALE				
mm	NTS			PICO-CLASP 1.0 W/B SINGLE ROW VT SMT INNER LOCK GOLD PLATING LOW HALOGEN	
GENERAL TOLERANCES (UNLESS SPECIFIED)		EC NO: 626442		DOCUMENT NUMBER	
ANGULAR TOL	± 3.0°	DRWN: AISHIKAWA	2019/06/21	2083810000-SD	
4 PLACES	± 0.2	CHK'D: AIDA	2019/12/25	DOC TYPE	DOC PART
3 PLACES	± 0.2	APPR: SAKIYAMA	2019/12/25	PSD	000
2 PLACES	± 0.2	INITIAL REVISION:		REVISION	A
1 PLACE	± 0.2	DRWN: AISHIKAWA	2019/06/21		
0 PLACES	± 0.2	APPR: SAKIYAMA	2019/12/25		
DRAFT WHERE APPLICABLE MUST REMAIN WITHIN DIMENSIONS		THIRD ANGLE PROJECTION	DRAWING	SERIES	MATERIAL NUMBER
			A3-SIZE	208381	CUSTOMER
					SEE SHEET 6
					SHEET NUMBER
					3 OF 6

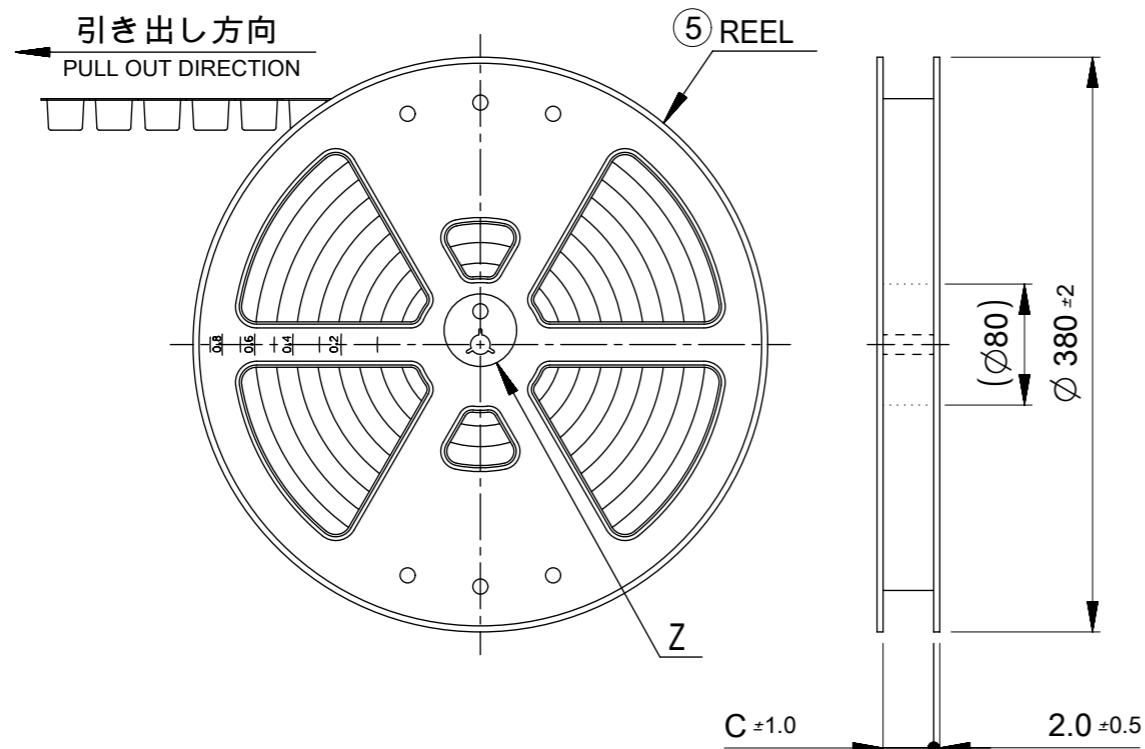

**NOTES**

- 10. 梱包数量:1100個/リール  
NUMBER OF CONNECTORS : 1100 PIECES/REEL
- 11. リードテープ長さ  
LEAD TAPE LENGTH

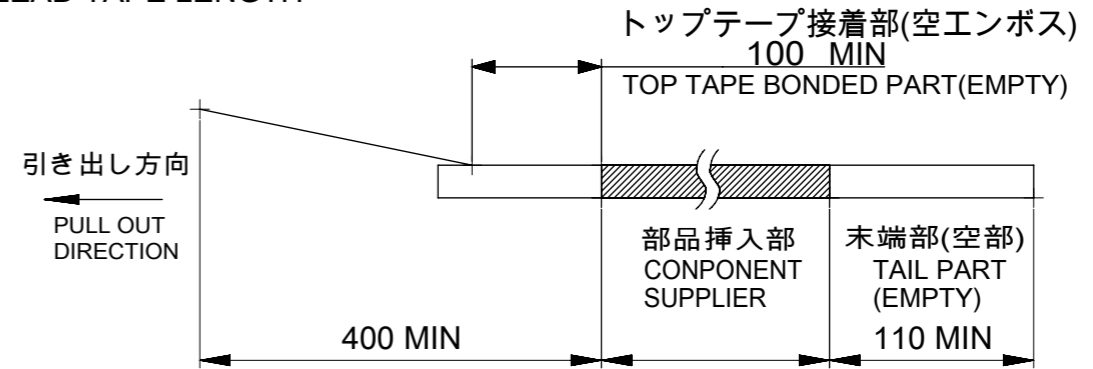

- 12. トップテープの剥離強度はIEC60286-3に準拠。  
TOP TAPE PEELING FORCE IS DEFINED BY IEC60286-3.
- 13. 梱包仕様書 : 2083819200-SPK PS 200  
PACKAGE SPECIFICATION:

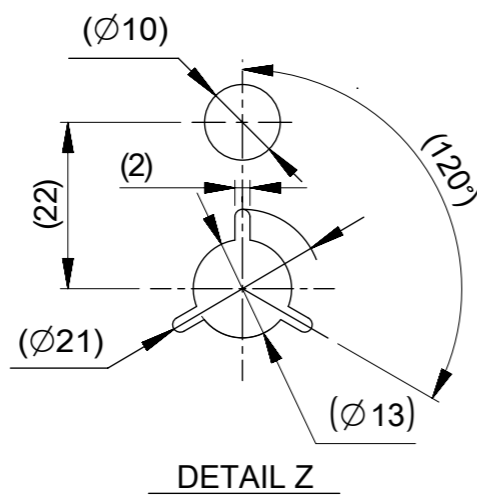

33.4	15
	14
	13
25.4	12
	11
	10
	9
	8
	7
17.5	6
	5
	4
	3
C	2
	極数 CIRCUIT SIZE

番号 NO.	部品 PART	材質 MATERIAL
⑤	リール REEL	ポリスチレン(PS) <リサイクル材を含む> POLYSTYRENE(PS) <RECYCLE MATERIAL CONTAINED>
DOCUMENT STATUS	P1	RELEASE DATE 2019/12/25 07:30:31

THIS DRAWING CONTAINS INFORMATION THAT IS PROPRIETARY TO MOLEX ELECTRONIC TECHNOLOGIES, LLC AND SHOULD NOT BE USED WITHOUT WRITTEN PERMISSION		CURRENT REV DESC:		<b>molex</b>	
DIMENSION UNITS mm	SCALE NTS	EC NO: 626442 DRWN: AISHIKAWA 2019/06/21 CHK'D: AIDA 2019/12/25 APPR: SAKIYAMA 2019/12/25			
GENERAL TOLERANCES (UNLESS SPECIFIED)		INITIAL REVISION:		DOCUMENT NUMBER 2083810000-SD	
ANGULAR TOL	± 3.0 °	DRWN: AISHIKAWA 2019/06/21 APPR: SAKIYAMA 2019/12/25		DOC TYPE PSD	DOC PART 000
4 PLACES	± 0.2	DRAWING A3-SIZE		SHEET NUMBER 4 OF 6	REVISION A
3 PLACES	± 0.2	SERIES 208381		CUSTOMER SEE SHEET 6	
2 PLACES	± 0.2	MATERIAL NUMBER SEE SHEET 6			
1 PLACE	± 0.2	THIRD ANGLE PROJECTION			
0 PLACES	± 0.2	DRAFT WHERE APPLICABLE MUST REMAIN WITHIN DIMENSIONS			

2~5 CIRCUITS

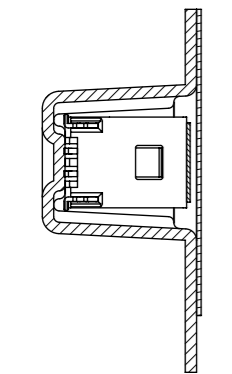

SECTION Y-Y

引き出し方向  
PULL OUT DIRECTION

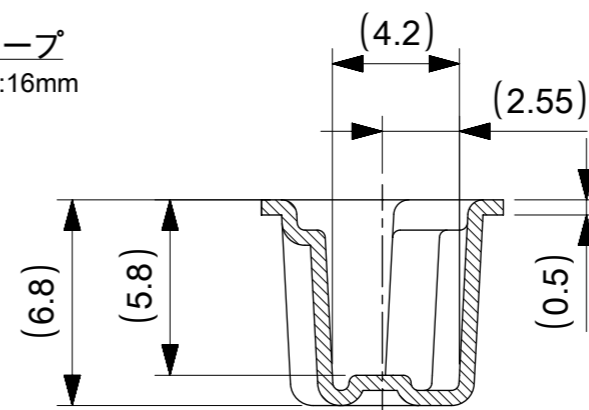
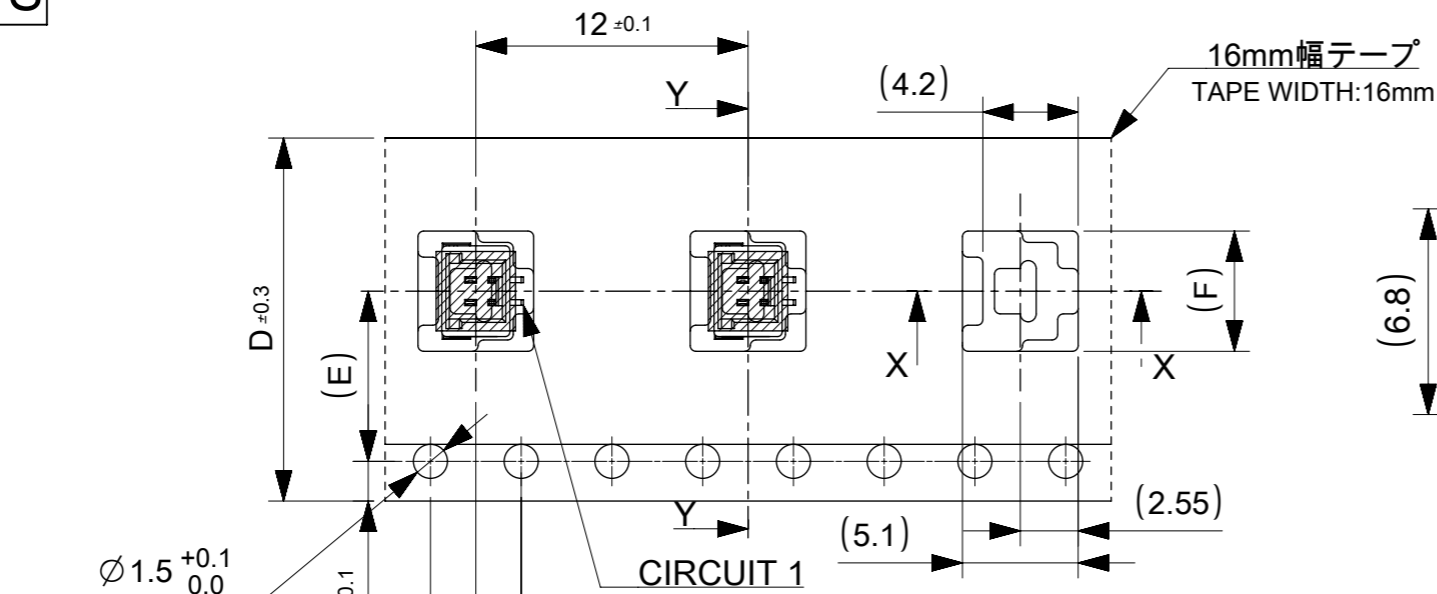

SECTION X-X

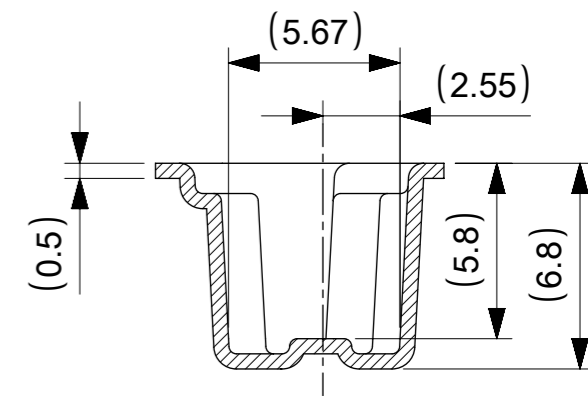

SECTION V-V

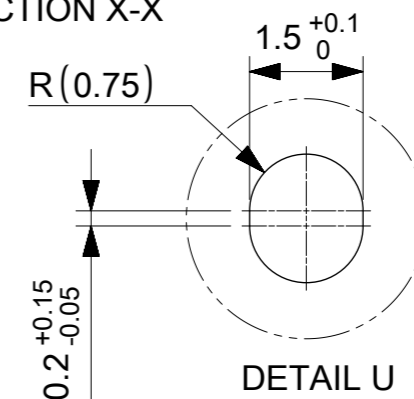

6~15 CIRCUITS

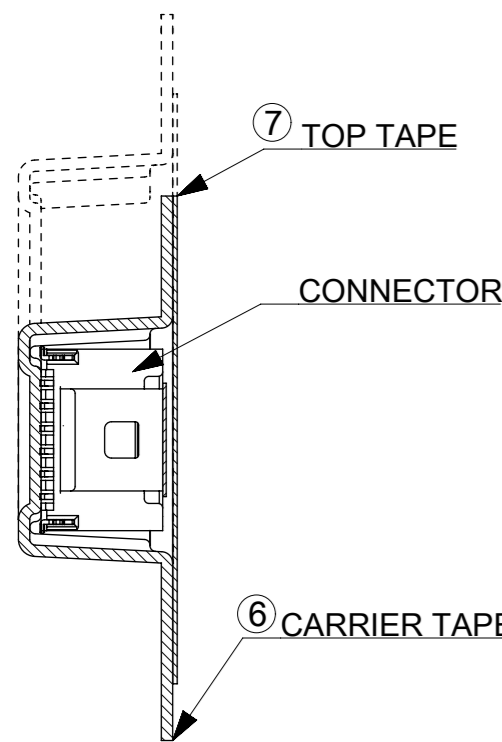

SECTION W-W

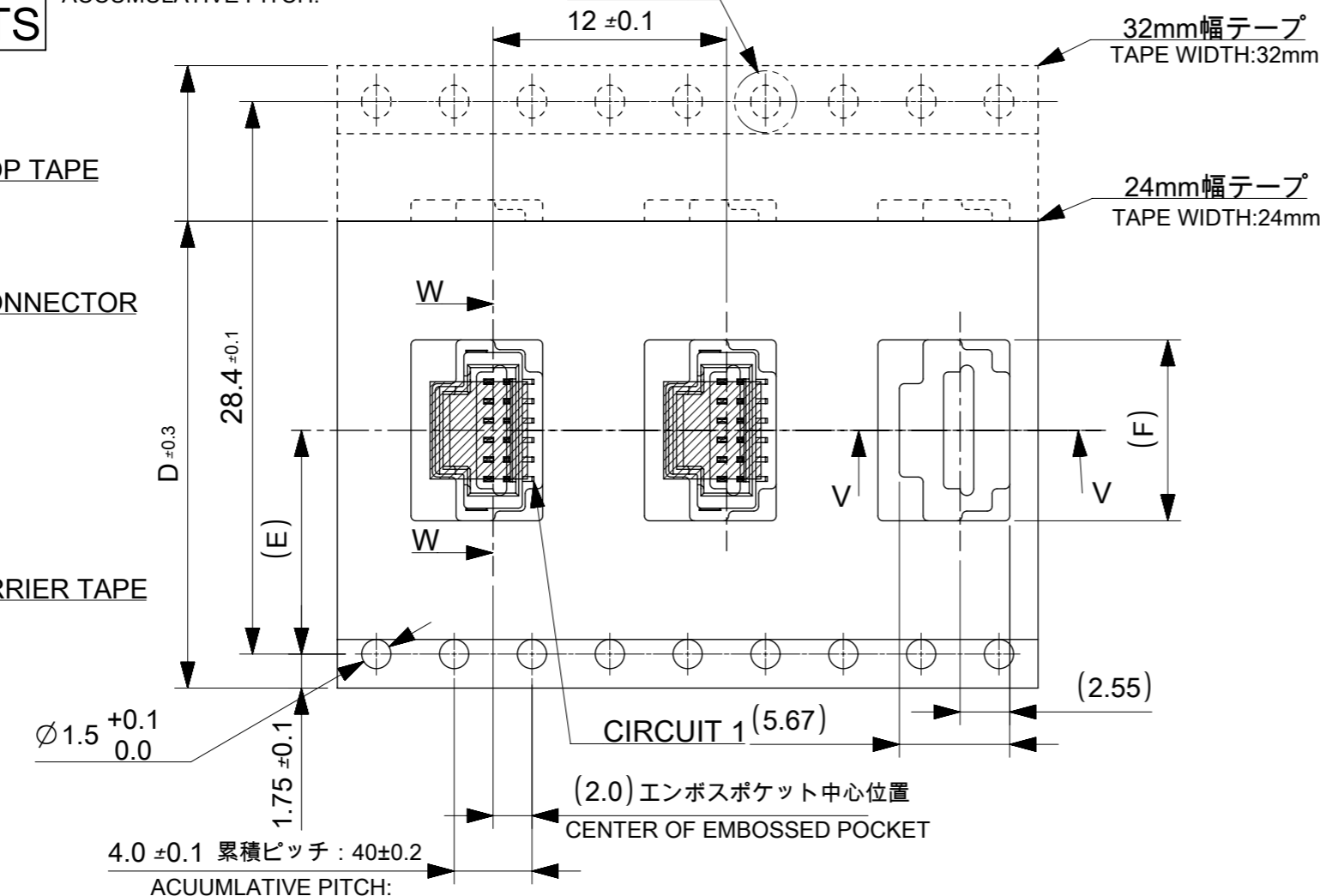

18.3			15
17.3	14.2	32	14
16.3			13
15.3			12
14.3			11
13.3			10
12.3	11.5	24	9
11.3			8
10.3			7
9.3			6
8.3			5
7.3	7.5	16	4
6.3			3
5.3			2
F	コネクタ中心位置 E CENTER OF CONNECTOR	エンボステープ幅 D WIDTH OF TAPE	極数 CIRCUIT SIZE

番号 NO.	部品 PART	材質 MATERIAL
⑥	キャリアテープ CARRIER TAPE	ポリプロピレン(PP)、その他 POLYPROPYLEN(PP), etc
⑦	トップテープ TOP TAPE	ポリエチレン(PE)、その他 POLYETHYLENE(PE), etc

DOCUMENT STATUS	P1	RELEASE DATE	2019/12/25	07:30:31
-----------------	----	--------------	------------	----------

THIS DRAWING CONTAINS INFORMATION THAT IS PROPRIETARY TO MOLEX ELECTRONIC TECHNOLOGIES, LLC AND SHOULD NOT BE USED WITHOUT WRITTEN PERMISSION

SCALE: mm NTS

GENERAL TOLERANCES (UNLESS SPECIFIED):

ANGULAR TOL ± 3.0°

4 PLACES ± 0.2

3 PLACES ± 0.2

2 PLACES ± 0.2

1 PLACE ± 0.2

0 PLACES ± 0.2

THIRD ANGLE PROJECTION

DRAWING: A3-SIZE

SERIES: 208381

MATERIAL NUMBER: SEE SHEET 6

CUSTOMER: 2083810000-SD

DOC TYPE: PSD

DOC PART: 000

REVISION: A

SHEET NUMBER: 5 OF 6

CURRENT REV DESC:

EC NO: 626442

DRWN: AISHIKAWA 2019/06/21

CHK'D: AIDA 2019/12/25

APPR: SAKIYAMA 2019/12/25

INITIAL REVISION:

DRWN: AISHIKAWA 2019/06/21

APPR: SAKIYAMA 2019/12/25

PRODUCT CUSTOMER DRAWING

DOCUMENT NUMBER: 2083810000-SD

DOC TYPE: PSD

DOC PART: 000

REVISION: A

molex

PICO-CLASP 1.0 W/B  
SINGLE ROW VT SMT INNER LOCK GOLD PLATING  
LOW HALOGEN

E

E

D

D

C

C

B

B

A

A

10 製品一覧 PRODUCT LIST

0.76 MICRO-METER		0.38 MICRO-METER		0.1 MICRO-METER		金めっき厚 GOLD PLATING THICKNESS
黒 BLACK	自然色 NATURAL(BEIGE)	黒 BLACK	自然色 NATURAL(BEIGE)	黒 BLACK	自然色 NATURAL(BEIGE)	色 COLOR
208381 1513	208381 1503	208381 1515	208381 1505	208381 1517	208381 1507	15
∧ 1413	∧ 1403	∧ 1415	∧ 1405	∧ 1417	∧ 1407	14
1313	1303	1315	1305	1317	1307	13
1213	1203	1215	1205	1217	1207	12
1113	1103	1115	1105	1117	1107	11
1013	1003	1015	1005	1017	1007	10
0913	0903	0915	0905	0917	0907	9
0813	0803	0815	0805	0817	0807	8
0713	0703	0715	0705	0717	0707	7
0613	0603	0615	0605	0617	0607	6
0513	0503	0515	0505	0517	0507	5
0413	0403	0415	0405	0417	0407	4
∨ 0313	∨ 0303	∨ 0315	∨ 0305	∨ 0317	∨ 0307	3
208381 0213	208381 0203	208381 0215	208381 0205	208381 0217	208381 0207	2
発注番号 ORDER No.						極数
PACKAGING STYLE : EMBOSSED TAPE AND REEL						CIRCUIT SIZE

THIS DRAWING CONTAINS INFORMATION THAT IS PROPRIETARY TO MOLEX ELECTRONIC TECHNOLOGIES, LLC AND SHOULD NOT BE USED WITHOUT WRITTEN PERMISSION

DIMENSION UNITS mm	SCALE NTS	CURRENT REV DESC:		<b>molex</b>		
GENERAL TOLERANCES (UNLESS SPECIFIED)		EC NO: 626442				
ANGULAR TOL ± 3.0 °	4 PLACES ± 0.2	DRWN: AISHIKAWA 2019/06/21		SINGLE ROW VT SMT INNER LOCK GOLD PLATING		
3 PLACES ± 0.2	2 PLACES ± 0.2	CHK'D: AIDA 2019/12/25		LOW HALOGEN		
1 PLACE ± 0.2	0 PLACES ± 0.2	APPR: SAKIYAMA 2019/12/25		PRODUCT CUSTOMER DRAWING		
DRAFT WHERE APPLICABLE MUST REMAIN WITHIN DIMENSIONS		INITIAL REVISION:		DOCUMENT NUMBER		
THIRD ANGLE PROJECTION		DRWN: AISHIKAWA 2019/06/21		2083810000-SD		
DRAWING		APPR: SAKIYAMA 2019/12/25		DOC TYPE DOC PART REVISION		
A3-SIZE		SERIES		PSD 000 A		
MATERIAL NUMBER		CUSTOMER		SEE SHEET 6		
SHEET NUMBER				6 OF 6		