

THIS DRAWING IS UNPUBLISHED. RELEASED FOR PUBLICATION
 © COPYRIGHT - By - ALL RIGHTS RESERVED.

LOC		DIST		REVISIONS			
P	LTR	DESCRIPTION		DATE	DWN	APVD	
CM	00	J		REVISED PER ECR-13-008204	10DEC2013	KH	TM

- 1 0.00076[.000030] MIN GOLD AT POINT OF MEASUREMENT IN THE LOCALIZED GOLD PLATE AREA, 0.00127[.000050] MIN TIN-LEAD IN TIN-LEAD PLATE AREA, 0.00127[.000050] MIN NICKEL UNDERPLATE ON ENTIRE CONTACT.
- 2 WIRE RANGE: 3-6mm² [12-10 AWG].
- 3 DIMENSIONS IN BRACKETS ARE IN INCHES.
- 4 0.00076[.000030] MIN GOLD AT POINT OF MEASUREMENT IN THE LOCALIZED GOLD PLATE AREA, 0.00127[.000050] MIN. TIN IN TIN PLATE AREA, 0.00127[.000050] MIN. NICKEL UNDERPLATE ON ENTIRE CONTACT.
- 5 THIS CONTACT HAS NO INSULATION BARREL.
- 6 SUPERCEDED BY 1-770246-0.

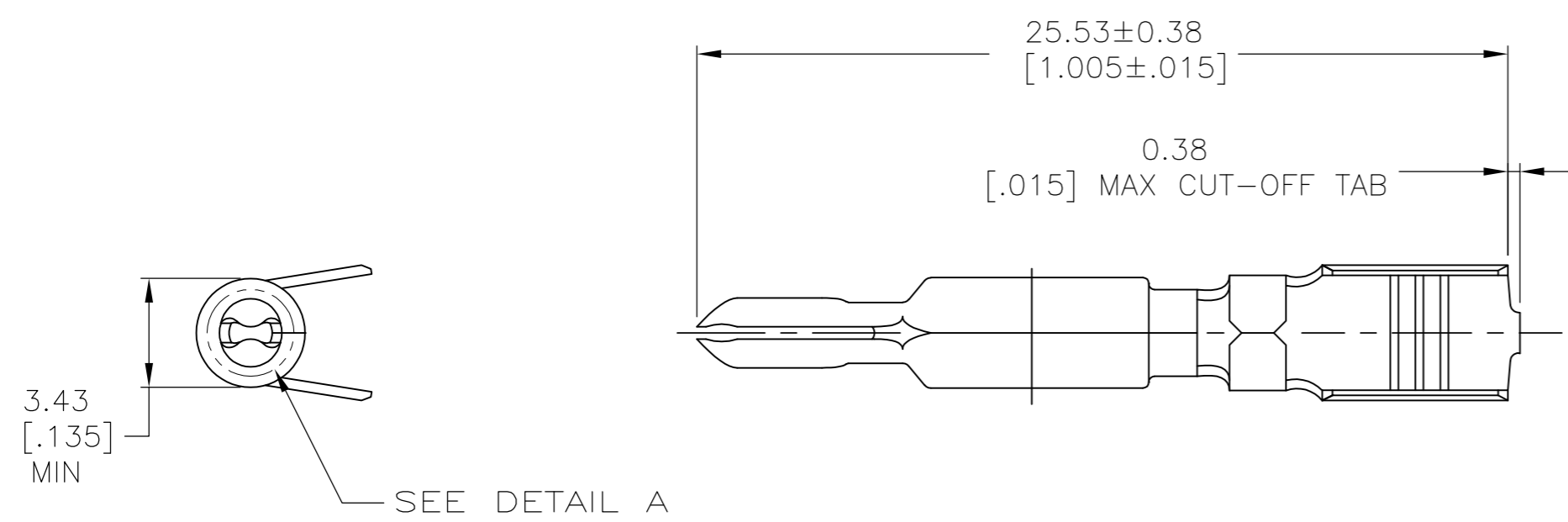

5.08
[.200] MIN
LOCALIZED GOLD
PLATE AREA
1 4

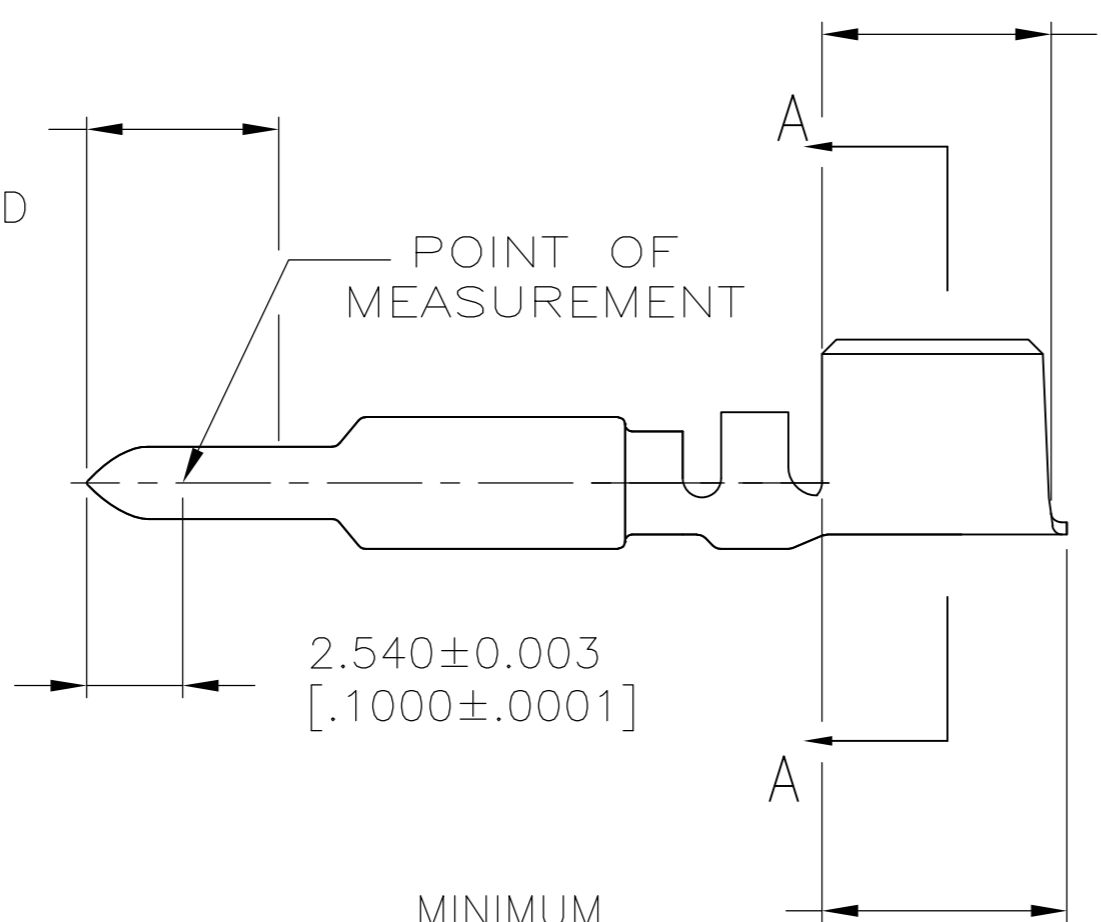

MINIMUM
LOCALIZED TIN OR
TIN-LEAD PLATE AREA
1 4

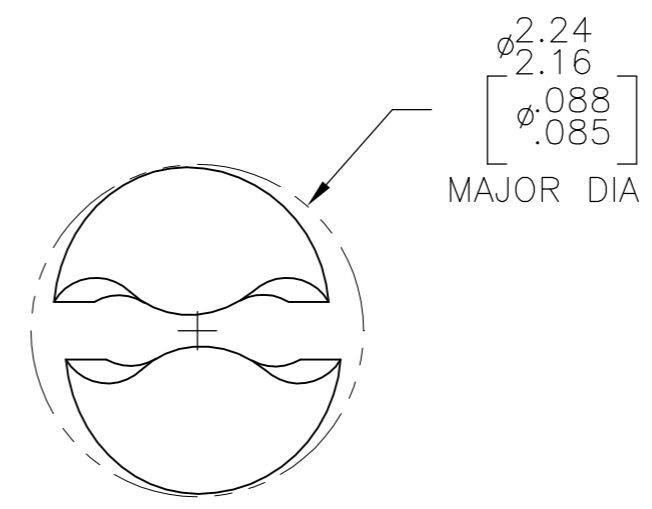

DETAIL A
SCALE 20:1

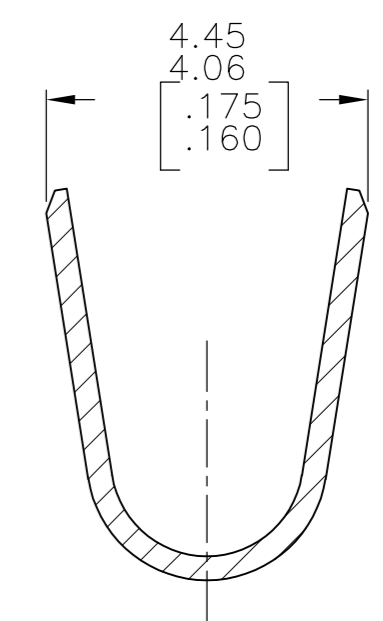

SECTION A-A
SCALE 10:1

FINISH	MATERIAL	PART NUMBER
GOLD 4	0.30 [.012] PH BRZ	1-770246-0
GOLD 1	0.30 [.012] PH BRZ	770246-4
PRE-TIN	0.30 [.012] PH BRZ	770246-3

THIS DRAWING IS A CONTROLLED DOCUMENT.		DWN K. WHITAKER 02APR04	TE Connectivity	
DIMENSIONS: mm [INCHES]		CHK C.JONES 02APR04	NAME PIN, LOOSE PIECE, UNIVERSAL MATE-N-LOK(TM) II	
TOLERANCES UNLESS OTHERWISE SPECIFIED:		APVD C.JONES 02APR04	SIZE A2	
0 PLC ± -	1 PLC ± -	PRODUCT SPEC	CAGE CODE 00779	DRAWING NO C=770246
2 PLC ± -	3 PLC ± -	APPLICATION SPEC	RESTRICTED TO	
4 PLC ± -	ANGLES ± -	WEIGHT	SCALE 5:1	SHEET 1 of 1
MATERIAL	FINISH	CUSTOMER DRAWING	REV J	