

# INTERVOX Speakers from International ©

215 McCormick Drive, Bohemia, NY 11716 (631)952-9595 Fax: (631) 952-9597 e-mail: [oemsales@icc107.com](mailto:oemsales@icc107.com)

Code No. G82

ICC Part No.	<b>S15X25VA (RoHS Compliant)</b>	
1. Size	41 x 71 mm	Weight: 38 grams
2. Materials	Magnet: Rare Earth	Housing: Metal
3. Power Rating	Nominal: 3 W	Maximum: 5 W
4. Voice Coil Impedance	$8 \Omega \pm 15 \%$	at 1K Hz 1.26V
5. Buzz & Rattles	Must not be evident	1.26V (const. voltage)
6. Resonant Frequency	250 Hz $\pm$ 70 Hz	at Fo Hz 1.26V
7. S.P.L.	86 dB/W $\pm$ 3 dB	1W 0.5M Average of 0.8, 1.0, 1.2, 1.5 KHz
8. Response	100 ~ 20K Hz Dev. 20dB Max.	1W 0.5M
9. Distortion	5% Maximum	1W 0.5M
10. Load Test	Speaker shall meet item 5 after test.	2W 8 Hours Use White Noise (EIA Filter)
11. Humidity Test	Speaker shall meet item 5, 6 & 9 after test.	40° C 90~95 % R.H. 8 Hrs.
12. Heat Test		70° C 20~50 % R.H. 8 Hrs.
13. Operating Temperature	-20° to +60° C	
14. Storage Temperature	-30° to +70° C	
15. Polarity	With Positive voltage applied to the (+) terminal, the cone shall move away from the pole piece.	

Dimensions:

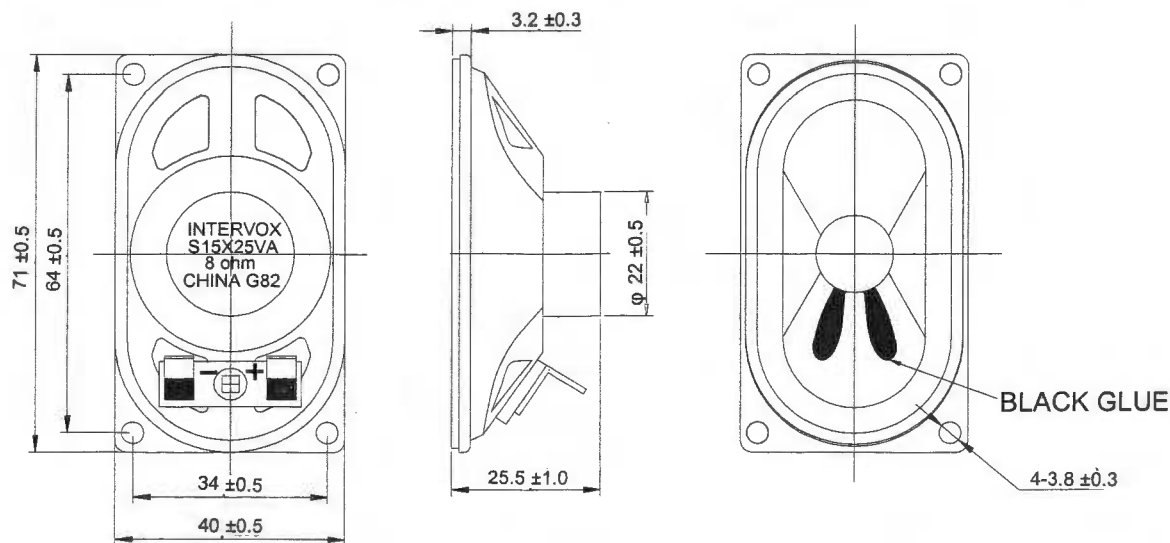

Model No. S15X25VA (RoHS Compliant)  
Code: G82

Imp.: 8  $\Omega$  1,000 Hz 2.83 V  
S.P.L.: 86 $\pm$ 3 dB 1 W 0.5 M

A: Frequency Response, Magn dB re 20.00 $\mu$ Pa

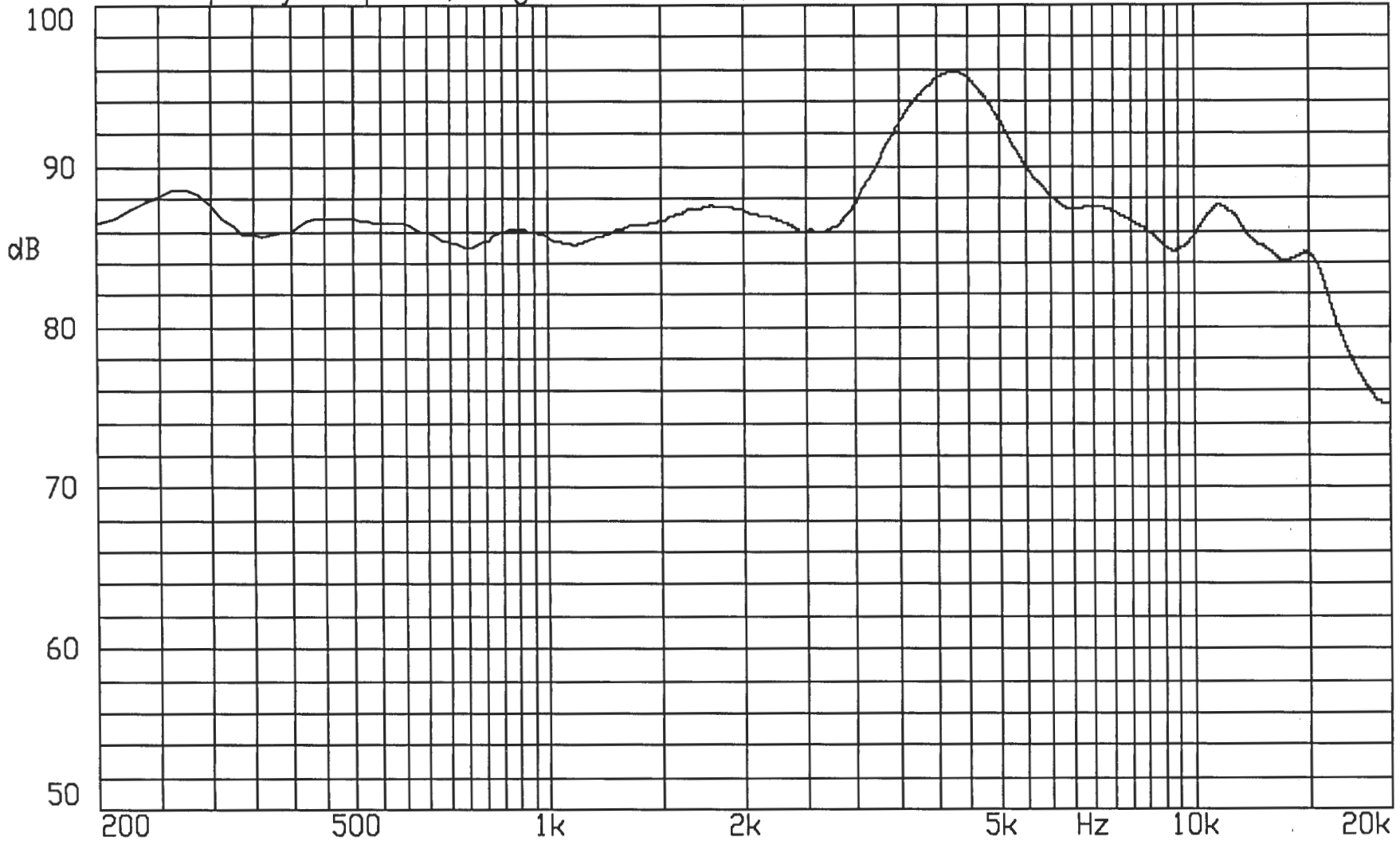

10-OCT-2008 09:19:01

Mode: TSR

