

CUSTOMER PRINT

PART NUMBER: 4182-XSG-300

NOTES:
 1. PARTS TO BE BULK PACKED
 2. CONTACTS ARE ASSEMBLED INTO CONNECTOR.

| ASSY P/N | NO. OF CONTACTS |
|--------------|-----------------|
| 4182-2SG-300 | 2 |
| 4182-3SG-300 | 3 |

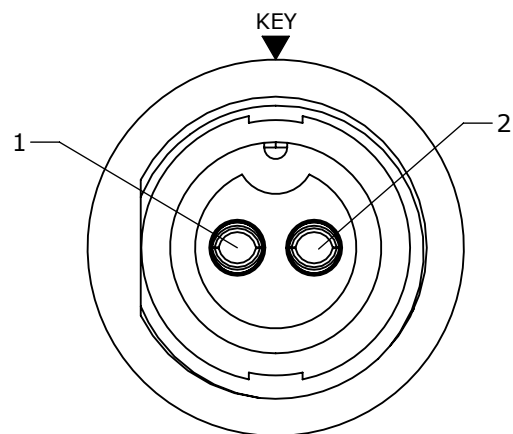

FACE VIEW
4182-2SG-300

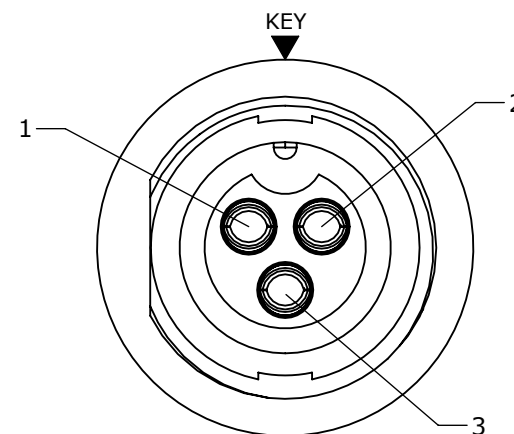

FACE VIEW
4182-3SG-300

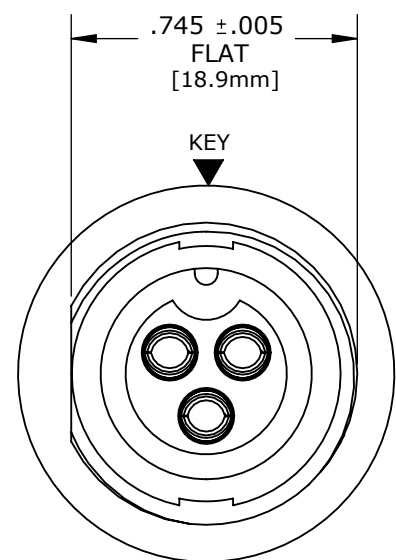

FACE VIEW
P/N: 4182-3SG-300

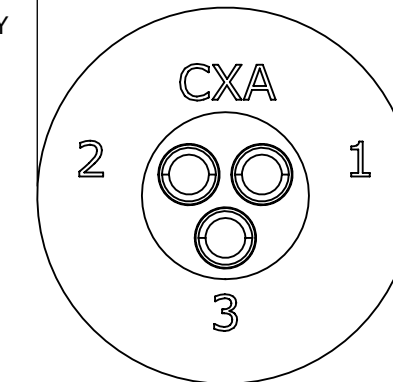
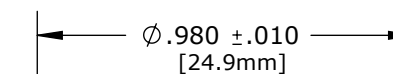
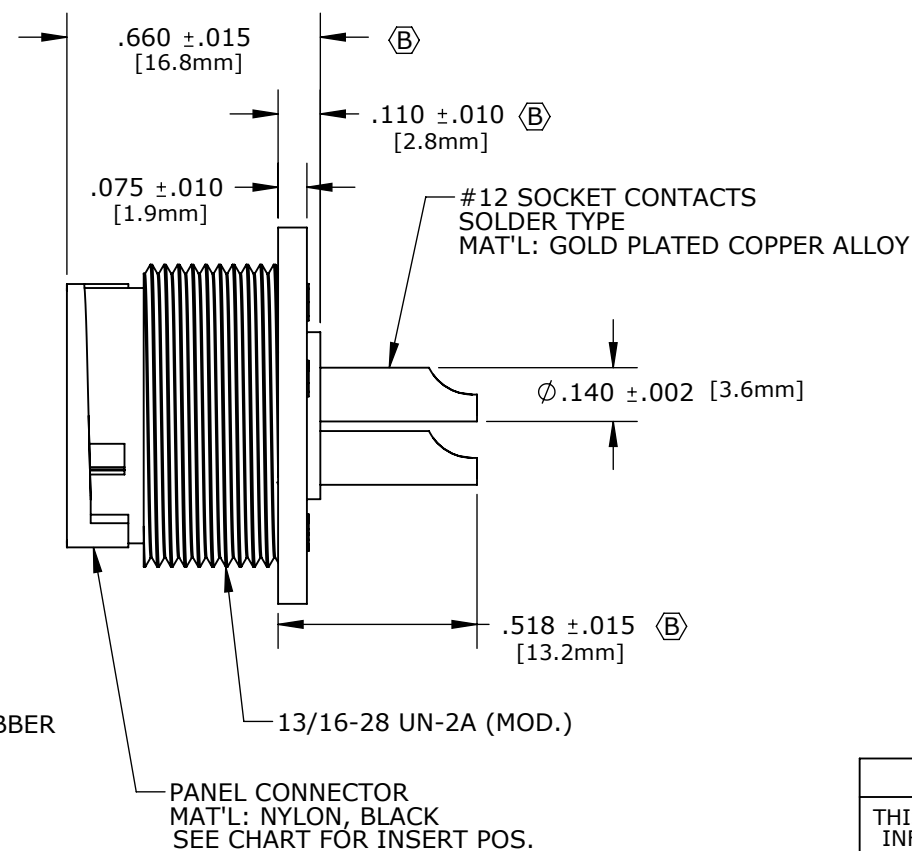
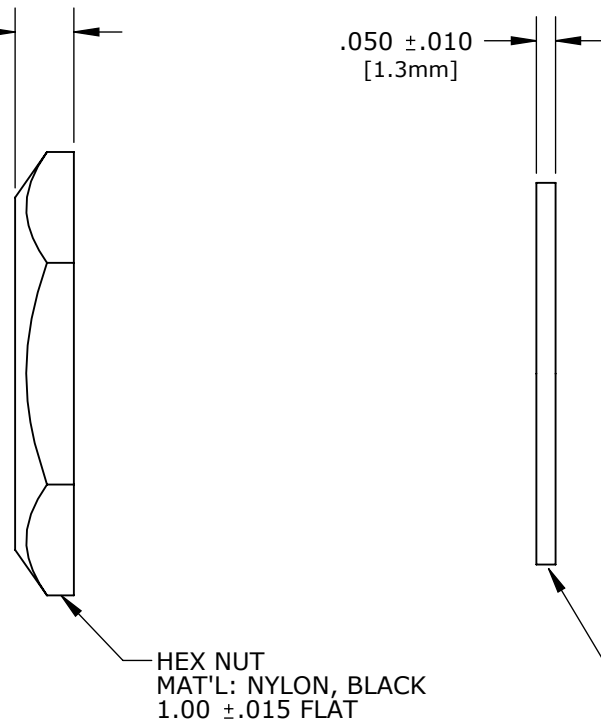
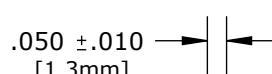
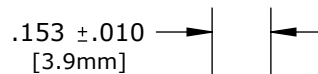

WIRE VIEW
P/N: 4182-3SG-300

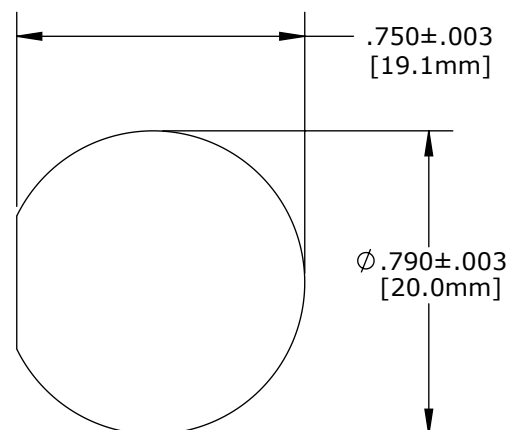

RECOMMENDED
PANEL CUT-OUT

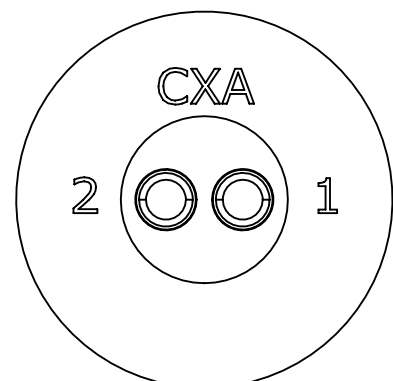

WIRE VIEW
4182-2SG-300

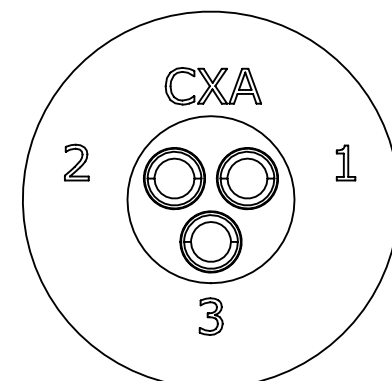

WIRE VIEW
4182-3SG-300

DIMENSIONS IN BRACKET [] ARE METRIC.

CUSTOMER APPROVAL

THIS DOCUMENT CONTAINS CONFIDENTIAL INFORMATION PROPRIETARY TO CONXALL CORPORATION. ANY REPRODUCTION, DISCLOSURE, OR USE OF THIS DOCUMENT / INFORMATION IS EXPRESSLY PROHIBITED UNLESS AUTHORIZED IN WRITING BY CONXALL CORPORATION.

APPROVED BY: _____
 DATE: _____

| | | | |
|------|-------|----------|--|
| B | AN | 09-14-10 | CORRECTED WITHOUT WELL, DIMENSION 0.660 WAS 0.705 & 0.518 WAS 0.526, ADDED TOLERANCES & MATERIAL. PER ECR 7569 |
| A | BZ | 10-12-09 | DRAWING CREATED PER DOR 09-1731KL |
| REV. | INIT. | DATE | DESCRIPTION |
| | | | ALL INFORMATION ILLUSTRATED IS THE PROPERTY OF "CONXALL CORPORATION". UNAUTHORIZED DUPLICATION OR DISTRIBUTION OF THIS DOCUMENT IS PROHIBITED. |
| | | | ORIG. DRAWN BY: BZ DATE: 10-12-09 |
| | | | CHECKED BY: |
| | | | APPROVED BY: |
| | | | UNLESS OTHERWISE SPECIFIED TOLERANCES: 3 PLACE DECIMALS ±.010 ANGLES ±1° FRACTIONS ±1/16 - CRITICAL CHARACTERISTIC FLAG PER SPEC. XXXX |
| | | | SCALE: NTS SIZE: B SHEET: 1 OF 1 |
| | | | FILE: 4182-XSG-300 DIRECTORY: SLW |
| | | | TITLE: PANEL CONNECTOR ASS'Y KIT (2-3) #12 SOCKET CONTACTS MULTI-CON-X CUSTOMER: STANDARD PRODUCT |
| | | | PART NUMBER: 4182-XSG-300 |
| | | | REV B |



601 E. WILDWOOD VILLA PARK, IL 60181