

# Accelerometer PCE-VT 2800

## INSTRUCTION MANUAL



Your purchase of this ACCELEROMETER with SD CARD DATALOGGER marks a step forward for you into the field of precision measurement. Although this METER is a complex and delicate instrument, its durable structure will allow many years of use if proper operating techniques are developed. Please read the following instructions carefully and always keep this manual within easy reach.



# OPERATION MANUAL

# TABLE OF CONTENTS

1. FEATURES.....	1
2. SPECIFICATIONS.....	2
3. FRONT PANEL DESCRIPTION.....	8
3-1 Display.....	8
3-2 Power Button ( ESC, Backlight Button ).....	8
3-3 Hold Button ( Function Button, Next Button ).....	8
3-4 REC Button ( Enter Button, Unit Button ).....	8
3-5 SET Button ( ▼ Button, Time check Button ).....	8
3-6 Logger Button ( ▲ Button, Sampling time check Button, Zero Button ) Max hold reset Button ).....	8
3-7 BNC Input Socket.....	8
3-8 SD Card Socket.....	8
3-9 RS-232 Output Terminal.....	8
3-10 Reset Button.....	8
3-11 DC 9V Power Adapter Input Socket.....	8
3-12 Battery Compartment/Cover.....	8
3-13 Battery Cover Screws.....	8
3-14 Stand.....	8
3-15 Tripod Fix Nut.....	8
3-16 Magnetic base.....	8
3-17 Vibration Sensor.....	8
3-18 Input Socket of Vibration Sensor .....	8
3-19 Mini Plug of Cable.....	8
3-20 Sensor Cable.....	8
3-21 Cable BNC Plug.....	8
4. MEASURING PROCEDURE.....	9
4-1 Preparation.....	9
4-2 Unit selection ( Acc./Velocity/Displacement selection ).....	10
4-3 Function selection .....	11
4-4 Zero adjustment procedures.....	12
4-5 Data Hold.....	13
4-6 Data Record ( Max./ Min. reading ).....	13
4-7 LCD Backlight ON/OFF.....	14
5. DATALOGGER.....	14
5-1 Preparation before execute datalogger function.....	14
5-2 Auto Datalogger ( Set sampling time $\geq$ 1 second ).....	15
5-3 Manual Datalogger ( Set sampling time = 0 second ).....	16
5-4 Check time information.....	17
5-5 Check sampling time information.....	17
5-6 SD Card Data structure.....	17
6. Saving data from the SD card to the computer.....	19
7. ADVANCED SETTING.....	20
7-1 Set clock time ( Year/Month/Date, Hour/Minute/ Second ).....	21
7-2 Decimal point of SD card setting.....	22
7-3 Auto power OFF management .....	22
7-4 Set beep Sound ON/OFF.....	23
7-5 Set sampling time .....	23
7-6 SD memory card format.....	23
8. POWER SUPPLY from DC ADAPTER.....	24
9. BATTERY REPLACEMENT.....	24
10. SYSTEM RESET.....	25
11. RS232 PC serial interface.....	25
12. CLASSIFICATION RANGES.....	27
13. SENSITIVITY RELATIVE according ISO 2954.....	28

# 1. FEATURES

- \* Applications for industrial vibration monitoring :  
All industrial machinery vibrates. The level of vibration is a useful guide to machine condition. Poor balance, misalignment & looseness of the structure will cause the vibration level increase, it is a sure sign that the maintenance is needed.
- \* Frequency range 10 Hz - 1 kHz, sensitivity relative meet ISO 2954.
- \* Professional vibration meter supply with vibration sensor & magnetic base, full set.
- \* Metric & Imperial display unit
- \* Acceleration, Velocity, Displacement measurement.
- \* RMS, Max hold, Peak value measurement.
- \* Max. Hold reset button, Zero button.
- \* Wide frequency range.
- \* Data hold button to freeze the desired reading.
- \* Memory function to record maximum and minimum reading with recall.
- \* Separate vibration probe with magnetic base, easy operation.
- \* Real time SD memory card Datalogger, it Built-in Clock and Calendar, real time data recorder , sampling time set from 1 second to 3600 seconds.
- \* Manual datalogger is available ( set the sampling time to 0 ), during execute the manual datalogger function, it can set the different position ( location ) No. ( position 1 to position 99 ).
- \* Innovation and easy operation, computer is not need to setup extra software, after execute datalogger, just take away the SD card from the meter and plug in the SD card into the computer, it can down load the all the measured value with the time information ( year/month/date/ hour/minute/second ) to the Excel directly, then user can make the further data or graphic analysis by themselves.

- \* SD card capacity : 1 GB to 16 GB.
- \* LCD with green light backlight, easy reading.
- \* Can default auto power off or manual power off.
- \* Data hold, record max. and min. reading.
- \* Microcomputer circuit, high accuracy.
- \* Power by UM3/AA ( 1.5 V ) x 6 batteries or DC 9V adapter.
- \* RS232/ USB PC COMPUTER interface.

## 2. SPECIFICATIONS

### *2-1 General Specifications*

Circuit	Custom one-chip of microprocessor LSI circuit.		
Display	LCD size : 52 mm x 38 mm LCD with green backlight ( ON/OFF ).		
Measurement	Velocity, Acceleration, Displacement		
Function	<i>Acceleration, Velocity :</i> RMS, Peak, Max Hold. <i>Displacement :</i> p-p ( peak-peak ), Max Hold p-p.		
Unit	<i>Measurement</i>	<i>Metric</i>	<i>Imperial</i>
	Acceleration	meter/s <sup>2</sup> , g	ft/s <sup>2</sup> ,
	Velocity	mm/s, cm/s	inch/s
	Displacement	mm	inch
Frequency range	10 Hz to 1 KHz * <i>Sensitivity relative during the the frequency range meet ISO 2954 Refer to table 1, page 28</i>		
Circuit	Exclusive microcomputer circuit.		
Peak Measurement	<i>Acceleration, Velocity :</i> To measure and update the peak value. <i>Displacement :</i> To measure and update the peak to peak ( p-p ) value.		

Max Hold Measurement	<i>Acceleration, Velocity :</i> To measure and update the max. peak value.	
	<i>Displacement :</i> To measure and update the max. peak to peak ( p-p ) value.	
Zero Button	Under Acceleration ( RMS ) measurement, sensor motionless , press Logger Button ( 3-6, Fig. 1 ) > 5 seconds.	
Max. Hold Reset Button	Under Max. hold measurement, press Logger Button ( 3-6, Fig. 1 ) > 5 seconds.	
Datalogger Sampling Time Setting range	Auto	1 second to 3600 seconds <i>@ Sampling time can set to 1 second, but memory data may loss.</i>
	Manual	Push the data logger button once will save data one time. <i>@ Set the sampling time to 0 second.</i> <i>@ Manual mode, can also select the 1 to 99 position ( Location ) no.</i>
Memory Card	SD memory card 1 GB to 16 GB.	
Advanced setting	<ul style="list-style-type: none"> <li>* Set clock time ( Year/Month/Date, Hour/Minute/ Second )</li> <li>* Decimal point of SD card setting</li> <li>* Auto power OFF management</li> <li>* Set beep Sound ON/OFF</li> <li>* Set sampling time</li> <li>* SD memory card Format</li> </ul>	
Data error no.	$\leq 0.1$ % no. of total saved data typically.	
Data Hold	Freeze the display reading. <i>* Only available for the RMS function.</i>	
Memory Recall	Maximum & Minimum value. <i>* Only available for the RMS function.</i>	

Data Output	RS 232/USB PC computer interface. * <i>Connect the optional RS232 cable UPCB-02 will get the RS232 plug.</i> * <i>Connect the optional USB cable USB-01 will get the USB plug.</i>
Sampling Time of Display	Approx. 1 second.
Operating Temperature and Humidity	0 to 50 °C. Less than 85% R.H.
Power Supply	* Alkaline or heavy duty DC 1.5 V battery ( UM3, AA ) x 6 PCs, or equivalent.
	* DC 9V adapter input. ( AC/DC power adapter is optional ).
Power Current	Normal operation ( w/o SD card save data and LCD Backlight is OFF ) : <i>Approx. DC 15 mA.</i>
	When SD card save the data and LCD Backlight is OFF) : <i>Approx. DC 36 mA.</i>
Weight	<i>Meter : 515 g/ 1.13 LB.</i>
	<i>Probe with cable and magnetic base : 99 g/0,22 LB</i>
Dimension	<i>Meter : 203 x 76 x 38 mm</i> <i>Vibration sensor probe:</i> Round 16 mm Dia. x 37 mm. Cable length : 1.2 meter.
Accessories Included	* Instruction manual..... 1 PC * Hrad carrying case, CA-06..... 1 PC * Vibration sensor with cable..... 1 PC * Magnetic base..... 1 PC
Optional Accessories	SD Card ( 2 G ) AC to DC 9V adapter. USB cable, USB-01. RS232 cable, UPCB-02. Data Acquisition software, SW-U801-WIN.

*2-2 Electrical Specifications (23± 5 °C)*

**Acceleration ( RMS, Peak, Max Hold )**

Unit	m/s <sup>2</sup>
Range	0.5 to 199.9 m/s <sup>2</sup>
Resolution	0.1 m/s <sup>2</sup>
Accuracy	± ( 5 % + 2 d ) reading @ 160 Hz, 80 Hz, 23 ± 5 °C
Calibration Point	50 m/S <sup>2</sup> ( 160 Hz )

Unit	g @ 1 g = 9.8 m/s <sup>2</sup>
Range	0.05 to 20.39 G
Resolution	0.01 G
Accuracy	± ( 5 % + 2 d ) reading @ 160 Hz, 80 Hz, 23 ± 5 °C
Calibration Point	50 m/S <sup>2</sup> ( 160 Hz )

Unit	ft/s <sup>2</sup>
Range	2 to 656 ft/s <sup>2</sup>
Resolution	1 ft/s <sup>2</sup>
Accuracy	± ( 5 % + 2 d ) reading @ 160 Hz, 80 Hz, 23 ± 5 °C
Calibration Point	50 m/S <sup>2</sup> ( 160 Hz )

*Remark :*

*RMS : To measure the true RMS value.*

*Peak : To measure and update the peak value.*

*Max. Hold : To measure and update the max. peak value.*

**Velocity ( RMS, Peak, Max Hold )**

Unit	mm/s
Range	0.5 to 199.9 mm/s
Resolution	0. 1 mm/s
Accuracy	$\pm ( 5 \% + 2 d )$ reading @ 160 Hz, 80 Hz, $23 \pm 5 ^\circ \text{C}$
Calibration Point	50 mm/s ( 160 Hz )

Unit	cm/s
Range	0.05 to 19.99 cm/s
Resolution	0. 01 cm/s
Accuracy	$\pm ( 5 \% + 2 d )$ reading @ 160 Hz, 80 Hz, $23 \pm 5 ^\circ \text{C}$
Calibration Point	50 mm/s ( 160 Hz )

Unit	inch/s
Range	0.02 to 7.87 inch/s
Resolution	0.01 inch/s
Accuracy	$\pm ( 5 \% + 2 d )$ reading @ 160 Hz, 80 Hz, $23 \pm 5 ^\circ \text{C}$
Calibration Point	50 mm/s ( 160 Hz )

*Remark :*

*RMS : To measure the true RMS value.*

*Peak : To measure and update the peak value.*

*Max. Hold : To measure and update the max. peak value.*



**Displacement ( p-p, Max Hold p-p )**

Unit	mm
Range	1.999 mm
Resolution	0.001 mm
Accuracy	$\pm ( 5 \% + 2 d )$ reading <i>@ 160 Hz, 80 Hz, 23 <math>\pm</math> 5 <math>^{\circ}</math>C</i>
Calibration Point	0.141 mm ( 160 Hz )

Unit	inch
Range	0.078 inch
Resolution	0.001 inch
Accuracy	$\pm ( 5 \% + 2 d )$ reading <i>@ 160 Hz, 80 Hz, 23 <math>\pm</math> 5 <math>^{\circ}</math>C</i>
Calibration Point	0.141 mm ( 160 Hz )

*Remark :*

*p-p :*

*To measure the Peak to Peak value.*

*Max. Hold p-p :*

*To measure and update the max. Peak to Peak value.*

*@ Above specification tests under the environment RF Field Strength less than 3 V/M & frequency less than 30 MHz only.*

## 3. FRONT PANEL DESCRIPTION

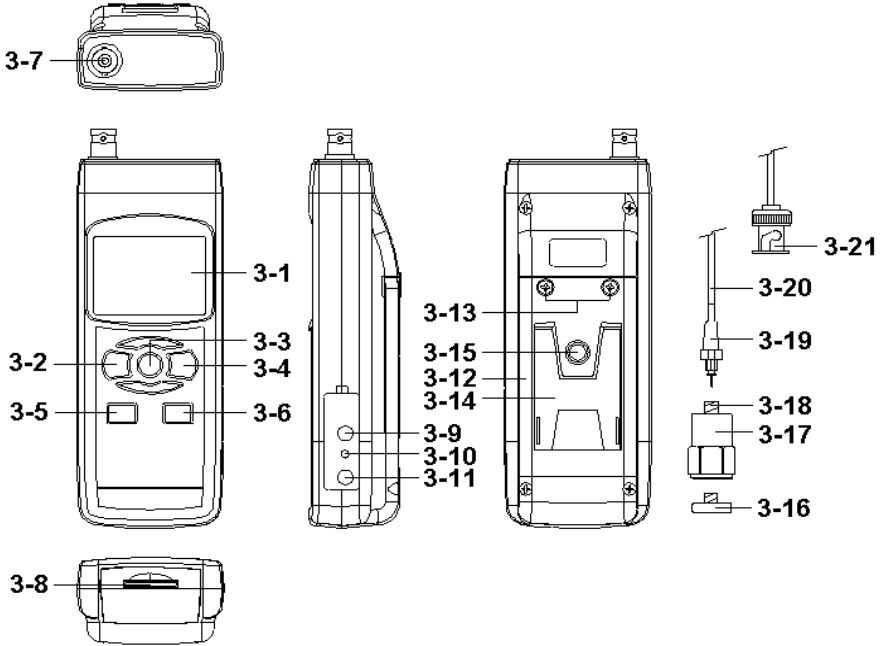

Fig. 1

- 3-1 Display
- 3-2 Power Button ( ESC, Backlight Button )
- 3-3 Hold Button ( Function Button, Next Button )
- 3-4 REC Button ( Enter Button, Unit Button )
- 3-5 SET Button ( ▼ Button, Time check Button )
- 3-6 Logger Button ( ▲ Button, Sampling time check Button, Zero Button, Max hold reset Button )
- 3-7 BNC Input Socket
- 3-8 SD Card Socket
- 3-9 RS-232 Output Terminal
- 3-10 Reset Button
- 3-11 DC 9V Power Adapter Input Socket
- 3-12 Battery Compartment/Cover
- 3-13 Battery Cover Screws
- 3-14 Stand
- 3-15 Tripod Fix Nut
- 3-16 Magnetic Base
- 3-17 Vibration Sensor
- 3-18 Input Socket of Vibration Sensor
- 3-19 Mini Plug of Cable
- 3-20 Sensor Cable
- 3-21 Cable BNC Plug

## 4. MEASURING PROCEDURE

### 4-1 Preparation

1) Turn on the meter by pressing the " Power Button "  
( 3-2, Fig. 1 ) momentarily.

*\* Pressing the " Power Button " ( 3-2, Fig. 1 )  
continuously and > 2 seconds again will turn off the  
meter.*

2) Plug in the " Cable BNC Plug " ( 3-21, Fig. 1 )  
to the " BNC Input Socket " ( 3-7, Fig. 1 ).

3) Plug in the " Mini plug of cable " ( 3-19, Fig. 2 )  
to the " Input socket of vibration sensor " ( 3-18, Fig. 2 ).

### *Remark :*

1. *If the surface material of measuring article is not  
the ferrous material, hold the vibration sensor by  
hand & touch the sensor to the surface of the  
measuring article,*

*\* If the surface material of measuring article is the  
ferrous material, connect " Vibration sensor " ( 3-17,  
Fig. 2 ) with the " Magnetic base " ( 3-16, Fig.  
2 ). Put the whole unit ( Vibration sensor &  
Magnetic base ) to the surface of measuring article.*

*\* Please do not use the finger or hand to touch the  
the " Sensor cable " ( 3-20, Fig. 1 ).*

#### 4-2 Unit selection ( Acc./ Velocity/ Displacement selection )

Select the desired display unit by pressing the " Unit Button " ( 3-4, Fig. 1 ) continuously ( not release the button ), the Display will show the following units according Acceleration/Velocity/Displacement in sequence.

<i>Measurement</i>	<i>Unit</i>
Acceleration <i>* LCD show " ACC "</i>	m/s <sup>2</sup> , g, ft/s <sup>2</sup>
Velocity <i>* LCD show " VEL. "</i>	mm/s, cm/s, inch/s
Displacement <i>* LCD show " DISP p-p "</i>	mm, inch.

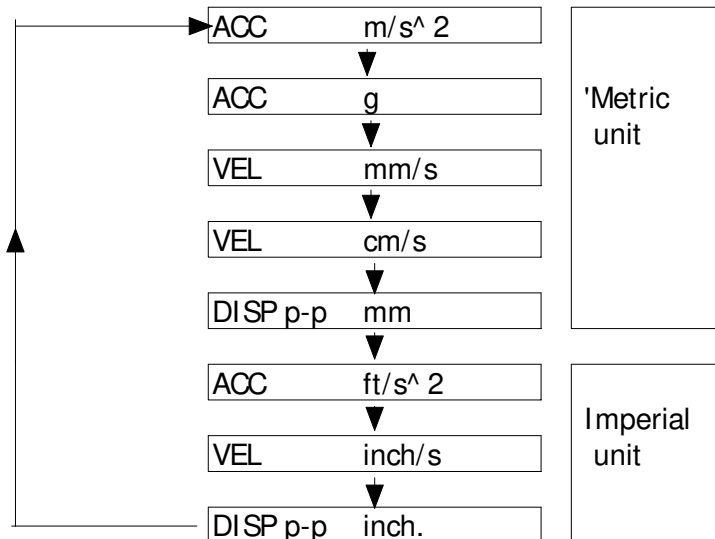

*Remark :*

- 1. For the Acceleration measurement, the Display will show the indicator " ACC "*
- 2. For the Velocity measurement, the Display will show the indicator " VEL. "*
- 3. For the Displacement measurement, the Display will show the indicator " DISP p-p "*
- 4. For general applications of industrial vibration monitoring, select " Velocity " or " Acceleration " typically.*
- 5. After select the unit will be saved into the circuit with default.*

#### *4-3 Function selection*

Select the desired function ( RMS, Peak, Max HOLD ) by pressing the " Function Button " ( 3-3, Fig. 1 ). continuously ( not release the button ), until the Display will show the desiring function ( RMS, Max HOLD, Peak ) , then release the " Function Button " ( 3-3, Fig. 1 ). The detail procedures, please refer to chapter 4-1, page 9. .

*Remarks :*

- 1. RMS measurement is intend to measure and root means square ( RMS ) value.  
The Display will show the indicator " RMS ".*
- 2. Max HOLD measurement is intend to measure and update the max. peak value.  
The Display will show the indicator " MAX HOLD ".*

#### **Max hold reset procedures**

Under execute the Max Hold function if press the " LOGGER Button " ( 3-6, Fig. 1 ) continuously at least 5 seconds will clear the existing Max hold value.

3. *Peak measurement is intend to measure the peak vibration value.  
The Display will show the indicator " PEAK ".*
4. *After select the unit will be saved into the circuit with default.*
5. *Acceleration and Velocity measurement can select 3 function : RMS, PEAK, MAX HOLD  
\* Typically, for Acceleration and Velocity measurement always select to the " RMS " measurement.*
6. *Displayment measurement can select 2 function :  
" DISP p-p " or MAX HOLD ( DISP p-p )  
\* Typically, for Displacement measurement always select to the " DISP p-p " measurement.*

#### *4-4 Zero adjustment procedures*

Due to drift of environment temperature value, battery power change, meter used for a long time or other reasons. The display value may exist not zero value ( few digits ) in case of no signal into the " Vibration Sensor ". General speaking those not zero value will not effect the measurement typically. However if intend to make the precision measurement, the following zero adjustment procedures should be executed as :

- 1) Vibration sensor is ready, connect the " Plug of cable " ( 3-21, Fig. 1 ) into the " " Input socket " ( 3-7, Fig. 1 ).
- 2) Select the measurement to the " Acceleration "
- 3) Keep the vibration sensor motionless, no signal into the vibration sensor.
- 4) Press the " LOGGER Button " ( 3-6, Fig. 1 ) continuously at least 5 seconds will let the display reach zero value.
- 5) The zero adjustment can be execute only the display value show the no. less than 10 digits.

#### 4-5 Data Hold

*\* Only available for the RMS function.*

During the measurement, press the " Hold Button " ( 3-3, Fig. 1 ) once will hold the measured value & the LCD will display a " HOLD " symbol.

Press the " Hold Button " once again will release the data hold function.

#### 4-6 Data Record ( Max., Min. reading )

*\* Only available for the RMS function.*

- 1) The data record function records the maximum and minimum readings. Press the " REC Button " ( 3-4, Fig. 1 ) once to start the Data Record function and there will be a " REC " symbol on the display.
- 2) With the " REC " symbol on the display :
  - a) Press the " REC Button " ( 3-4, Fig. 1 ) once, the " REC MAX " symbol along with the maximum value will appear on the display.  
If intend to delete the maximum value, just press the " Hold Button " ( 3-3, Fig. 1 ) once, then the display will show the " REC. " symbol only & execute the memory function continuously.
  - b) Press the " REC Button " ( 3-4, Fig. 1 ) again, the " REC MIN " symbol along with the minimum value will appear on the display.  
If intend to delete the minimum value, just press the " Hold Button " ( 3-3, Fig. 1 ) once, then the display will show the " REC. " symbol only & execute the memory function continuously.
  - c) To exit the memory record function, just press the " REC " button for 2 seconds at least. The display will revert to the current reading.

#### *4-7 LCD Backlight ON/ OFF*

After power ON, the " LCD Backlight " will light automatically. During the measurement, press the " Backlight Button " ( 3-2, Fig. 1 ) once will turn OFF the " LCD Backlight " .

Press the " Backlight Button " once again will turn ON the " LCD Backlight " again.

## **5. DATALOGGER**

### *5-1 Preparation before execute datalogger function*

#### a. Insert the SD card

Prepare a " SD memory card " ( 1 G to 16 G, optional ), insert the SD card into the " SD card socket " ( 3-8, Fig. 1 ). The front panel of the SD card should face against the the down case.

*\* It recommend use memory card's capacity is  $\leq 4$  GB.*

#### b. SD card Format

If SD card just the first time use into the meter, it recommend to make the " SD card Format " at first. , please refer chapter 7-6 ( page 23 ).

*\* It recommend strongly, do not use memory cards that have been formatted by other meter or by other installation ( such as camera... ). Reformat the memory card with your meter.*

*\* If the SD memory card exist the trouble during format by the meter, use the Computer to reformat again can fix the problem.*



c. Time setting

If the meter is used at first time, it should to adjust the clock time exactly, please refer chapter 7-1 ( page 21 ).

d. Decimal for



The numerical data structure of SD card is default used the " ." as the decimal, for example "20.6" "1000.53" . But in certain countries ( Europe ...) is used the " , " as the decimal point, for example " 20, 6 " "1000,53". Under such situation, it should change the Decimal character at first, details of setting the Decimal point, refer to Chapter 7-2, page 22.

*5-2 Auto Datalogger ( Set sampling time  $\geq$  1 second )*

**a. Start the datalogger**

Press the " REC Button ( 3-4, Fig. 1 ) once , the LCD will show the text " REC ", then press the " Logger Button " ( 3-6, Fig. 1 ), the " REC " will flashing, at the same time the measuring data along the time information will be saved into the memory circuit.

*Remark :*

*\* How to set the sampling time, refer to Chapter 7-5, page 23*

*\* How to set the beeper sound is enable, refer to Chapter 7-4, page 23*

#### **b. Pause the datalogger**

During execute the Datalogger function , if press the " Logger Button " ( 3-6, Fig. 1 ) once will pause the Datalogger function ( stop to save the measuring data into the memory circuit temporally ). In the same time the text of " REC " will stop flashing.

*Remark :*

*If press the " Logger Button " ( 3-6, Fig. 1 ) once again will execute the Datalogger again, the text of " REC " will flashing .*

#### **c. Finish the Datalogger**

During pause the Datalogger, press the " REC Button " ( 3-4, Fig. 1 ) continuously at least two seconds, the " REC " indication will be disappeared and finish the Datalogger.

*5-3 Manual Datalogger ( Set sampling time = 0 second )*

#### **a. Set sampling time is to 0 second**

Press the " REC Button ( 3-4, Fig. 1 ) once , the LCD will show the text " REC ", then press the " Logger Button " ( 3-6, Fig. 1 ) once, the " REC " will flashing once and Beeper will sound once, at the same time the measuring data along the time information will be saved into the memory circuit. The lower Display will show the Position ( Location ) no. and saved into the SD card too.

*Remark :*

*During execute the Manual Datalogger, press the " ▼ Button " ( 3-5, Fig. 1 ) the lower no. ( position no. ) will flashing. It can use the " ▲ Button " ( 3-6, Fig. 1 ) or " ▼ Button " ( 3-5, Fig. 1 ) to set the measuring position ( 1 to 99, for example room 1 to room 99 ) to identify the measurement location , the lower Display will show P x ( x = 1 to 99 ). After the position no. is selected, t press the " Enter Button " ( 3-4, Fig. 1 ) to confirm.*

#### **b. Finish the Datalogger**

Press the " REC Button " ( 3-4, Fig. 1 ) continuously at least two seconds, the " REC " indication will be disappeared and finish the Datalogger.

#### *5-4 Check time information*

During the normal measurement ( not execute the Datalogger ), If press " Time check Button " ( 3-5, Fig. 1 ) once , the lower LCD display will present the time information of Year, Month/Date, Hour/Minute

#### *5-5 Check sampling time information*

During the normal measurement ( not execute the Datalogger ), If press " Sampling Button " ( 3-6, Fig. 1 ) once , the lower LCD display will present the Sampling time information in second unit.

#### *5-6 SD Card Data structure*

- 1) When the SD card is used into the meter, the SD card  
When the first time, the SD card is used into the meter, the SD card will generate a folder :

*VBB01*

- 2) If the first time to execute the Datalogger, under the route VBB01\, will generate a new file name VBB01001.XLS.  
After exist the Datalogger, then execute again, the data will save to the VBB01001.XLS until Data column reach to 30,000 columns, then will generate a new file, for example VBB01002.XLS
- 3) Under the folder VBB01\, if the total files more than 99 files, will generate anew route, such as VBB02\ .....
- 4) The file's route structure :

```

VBB01\
    VBB01001.XLS
    VBB01002.XLS
    .....
VEVBB01099.XLS

    VBB02001.XLS
    VBB02002.XLS
    .....
VEVBB02099.XLS

    .....
    .....

```

*Remark :*  
*XX : Max. value is 10.*

## 6. Saving data from the SD card to the computer ( EXCEL software )

- 1) After execute the Data Logger function, take away the SD card out from the " SD card socket " ( 3-8, Fig. 1 ).
- 2) Plug in the SD card into the Computer's SD card slot ( if your computer build in this installation ) or insert the SD card into the " SD card adapter ". then connect the " SD card adapter " into the computer.
- 3) Power ON the computer and run the " EXCEL software ". Down load the saving data file ( for example the file name : VBB01001.XLS, VBB01002.XLS ) from the SD card to the computer. The saving data will present into the EXCEL software screen ( for example as following EXCEL data screens ) , then user can use those EXCEL data to make the further Data or Graphic analysis usefully.

EXCEL data screen ( for example )

	A	B	C	D	E
<b>19</b>	Place	Date	Time	Value	Unit
20	1	2010/9/6	10:06:44	0.47	ACC g
21	2	2010/9/6	10:06:46	0.51	ACC g
22	3	2010/9/6	10:06:48	0.53	ACC g
23	4	2010/9/6	10:06:50	0.46	ACC g
24	5	2010/9/6	10:06:52	0.48	ACC g
25	6	2010/9/6	10:06:54	0.51	ACC g
26	7	2010/9/6	10:06:56	0.47	ACC g
27	8	2010/9/6	10:06:58	0.51	ACC g
28	9	2010/9/6	10:07:00	0.55	ACC g
29	10	2010/9/6	10:07:02	0.51	ACC g
30	11	2010/9/6	10:07:04	0.46	ACC g
31	12	2010/9/6	10:07:06	0.51	ACC g
32	13	2010/9/6	10:07:08	0.45	ACC g
33	14	2010/9/6	10:07:10	0.52	ACC g
34	15	2010/9/6	10:07:12	0.51	ACC g

EXCEL graphic screen ( for example )

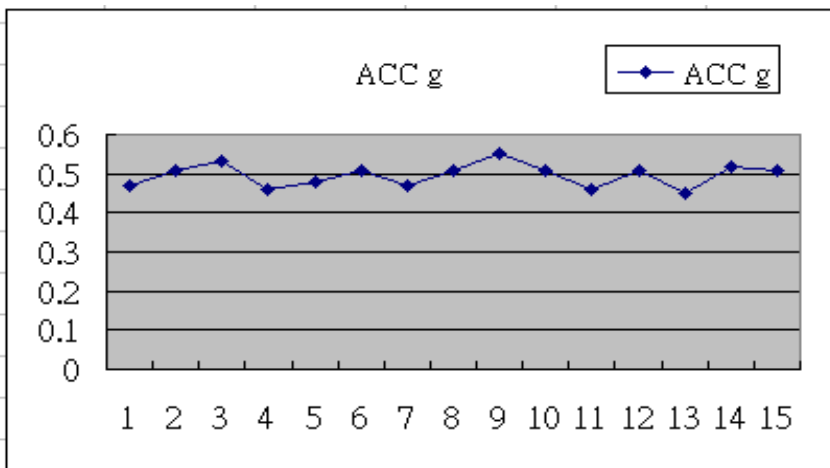

## 7. ADVANCED SETTING

Under do not execute the Datalogger function, press the " SET Button " ( 3-5, Fig. 1 ) continuously at least two seconds will enter the " Advanced Setting " mode. then press the " Next Button " (3-3, Fig. 1 ) once a while in sequence to select the eight main function, the lower display will show :

- dAtE.....Set clock time ( Year/Month/Date, Hour/Minute/Second )
- dEC.....Set SD card Decimal character
- PoFF..... Auto power OFF management
- bEEP.....Set beeper sound ON/OFF
- SP-t..... Set sampling time ( Hour/Minute/Second )
- Sd F..... SD memory card Format

*Remark :*

*During execute the " Advanced Setting " function, if press " Esc Button " ( 3-2, Fig. 1 ) once will exit the " Advanced Setting " function, the LCD will return to normal screen.*

*7-1 Set clock time ( Year/ Month/ Date, Hour/ Minute/ Second )*

When the lower display show " dAtE "

- 1) Press the " Enter Button " ( 3-4, Fig. 1 ) once, Use the " ▲ Button " ( 3-6, Fig. 1 ) or " ▼ Button " ( 3-5, Fig. 1 ) to adjust the value ( Setting start from Year value ). After the desired value is set, press the " Enter Button " ( 3-4, Fig. 1 ) once will going to next value adjustment ( for example, first setting value is Year then next to adjust Month, Date, Hour,
  
- 2) After set all the time value ( Year, Month, Date, Hour, Minute, Second ), the screen will jump to " Decimal point of SD card " setting screen ( Chapter 7-2 ).

*Remark :*

*After the time value is setting, the internal clock will run precisely even Power off if the battery is under normal condition ( No low battery power ).*

### *7-2 Decimal point of SD card setting*

The numerical data structure of SD card is default used the " ." as the decimal, for example "20.6" "1000.53" . But in certain countries ( Europe ...) is used the " ," as the decimal point, for example " 20,6 " "1000,53". Under such situation, it should change the Decimal character at first.

When the lower display show " dEC "

- 1) Use the " ▲ Button " ( 3-6, Fig. 1 ) or " ▼ Button " ( 3-5, Fig. 1 ) to select the upper value to " USA " or " Euro ".

USA - Use " ." as the Decimal point with default.  
Euro - Use " ," as the Decimal point with default.

- 2) After select the upper text to " USA " or " Euro ", press the " Enter Button " ( 3-4, Fig. 1 ) will save the setting function with default.

### *7-3 Auto power OFF management*

When the lower display show " PoFF "

- 1) Use the " ▲ Button " ( 3-6, Fig. 1 ) or " ▼ Button " ( 3-5, Fig. 1 ) to select the upper value to " yES " or " no ".

yES - Auto Power Off management will enable.  
no - Auto Power Off management will disable.

- 2) After select the upper text to " yES " or " no ", press the " Enter Button " ( 3-4, Fig. 1 ) will save the setting function with default.



#### *7-4 Set beeper sound ON/ OFF*

When the lower display show " bEEP "

- 1) Use the " ▲ Button " ( 3-6, Fig. 1 ) or " ▼ Button " ( 3-5, Fig. 1 ) to select the upper value to " yES " or " no ".

yES - Meter's beep sound will be ON with default.  
no - Meter's beep sound will be OFF with default.  
is power ON.

- 2) After select the upper text to " yES " or " no ", press the " Enter Button " ( 3-4, Fig. 1 ) will save the setting function with default.

function with default.

#### *7-5 Set sampling time ( seconds )*

When the lower display show " SP-t "

- 1) Use the " ▲ Button " ( 3-6, Fig. 1 ) or " ▼ Button " ( 3-5, Fig. 1 ) to adjust the value ( 1, 2, 5, 10, 30,60, 120, 300, 600, 1800,3600 seconds ).
- 2) After the Sampling value is selected, press the " Enter Button " ( 3-4, Fig. 1 ) will save the setting function with default.

#### *7-6 SD memory card Format*

When the lower display show " Sd F "

- 1) Use the " ▲ Button " ( 3-6, Fig. 1 ) or " ▼ Button " ( 3-5, Fig. 1 ) to select the upper value to " yES " or " no ".

yES - Intend to format the SD memory card  
no - Not execute the SD memory card format

- 2) If select the upper to " yES ", press the " Enter Button " ( 3-4, Fig. 1 ) once again, the Display will show text " yES Enter " to confirm again, if make sure to do the SD memory card format, then press " Enter Button " once will format the SD memory clear all the existing data that already saving into the SD card.

## 8. POWER SUPPLY from DC ADAPTER

The meter also can supply the power supply from the DC 9V Power Adapter ( optional ). Insert the plug of Power Adapter into " DC 9V Power Adapter Input Socket " ( 3-11, Fig. 1 ). The meter will permanent power ON when use the DC ADAPTER power supply ( The power Button function is disable ).

## 9. BATTERY REPLACEMENT

- 1) When the left corner of LCD display show " , it is necessary to replace the battery. However, in-spec. measurement may still be made for several hours after low battery indicator appears before the instrument become inaccurate.
- 2) Loose the screws of the " Battery Cover Screws " ( 3-13, Fig. 1 ) and take away the " Battery Cover " ( 3-12, Fig. 1 ) from the instrument and remove the battery.
- 3) Replace with DC 1.5 V battery ( UM3, AA, Alkaline/heavy duty ) x 6 PCs, and reinstate the cover.
- 4) Make sure the battery cover is secured after changing the battery.

## 10. SYSTEM RESET

If the meter happen the troubles such as :

*CPU system is hold ( for example, the key button can not be operated... ).*

Then make the system RESET will fix the problem.  
The system RESET procedures will be either following method :

During the power on, use a pin to press the " Reset Button " ( 3-10, Fig. 1 ) once a while will reset the circuit system.

## 11. RS232 PC SERIAL INTERFACE

The instrument has RS232 PC serial interface via a 3.5 mm terminal ( 3-9, Fig. 1 ).

The data output is a 16 digit stream which can be utilized for user's specific application.

A RS232 lead with the following connection will be required to link the instrument with the PC serial port.

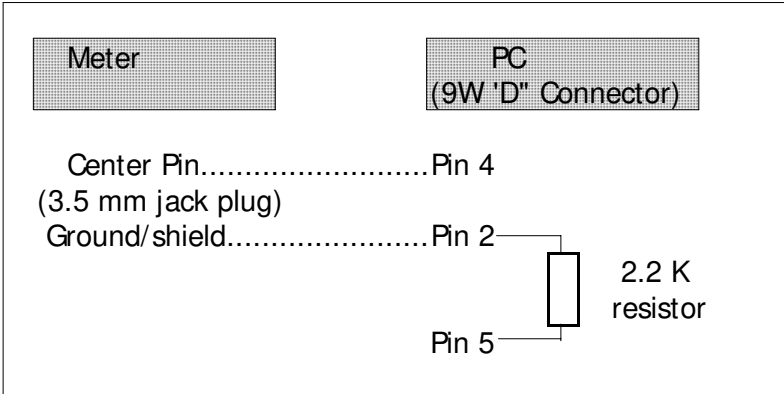

The 16 digits data stream will be displayed in the following format :

D15 D14 D13 D12 D11 D10 D9 D8 D7 D6 D5 D4 D3 D2 D1 D0

Each digit indicates the following status :

D15	Start Word									
D14	4									
D13	1									
D12, D11	Annunciator for Display									
	<table border="1"> <tr> <td>m/s<sup>2</sup> = 92</td> <td>ft/s<sup>2</sup> = 97</td> <td></td> </tr> <tr> <td>mm/s = 93</td> <td>cm/s = 95</td> <td>inch/s = 98</td> </tr> <tr> <td>mm = 94</td> <td>inch = 96</td> <td>g = 57</td> </tr> </table>	m/s <sup>2</sup> = 92	ft/s <sup>2</sup> = 97		mm/s = 93	cm/s = 95	inch/s = 98	mm = 94	inch = 96	g = 57
	m/s <sup>2</sup> = 92	ft/s <sup>2</sup> = 97								
	mm/s = 93	cm/s = 95	inch/s = 98							
mm = 94	inch = 96	g = 57								
D10	0									
D9	Decimal Point(DP), position from right to the left 0 = No DP, 1= 1 DP, 2 = 2 DP, 3 = 3 DP									
D8 to D1	Display reading, D1 = LSD, D8 = MSD <i>For example :</i> <i>If the display reading is 1234, then D8 to D1 is : 00001234</i>									
D0	End Word									

## RS232 FORMAT : 9600, N, 8, 1

Baud rate	9600
Parity	No parity
Data bit no.	8 Data bits
Stop bit	1 Stop bit

## 12. CLASSIFICATION RANGES

For the valuation of machines and equipment in the ISO 2372 and VDI 2056, four different kinds of machine groups with four classification ranges and their limits for vibration severity ( mm/s ) are determined.

The classifications for each machine group are specified as follows :

Small machines, especially production electrical motors of up to 15 KW ( Group K )

Good	0 to 0.71 mm/s
Acceptable	0.72 to 1.80 mm/s
Still permissible	1.81 to 4.5 mm/s
Dangerous	> 4.5 mm/s

Medium sized machines, especially electrical motors with 15 up to 75 KW output, without special foundations ( Group M )

Good	0 to 1.12 mm/s
Acceptable	1.13 to 2.80 mm/s
Still permissible	2.81 to 7.1 mm/s
Dangerous	> 7.1 mm/s

Large machines on heavy foundations ( Group G )

Good	0 to 1.80 mm/s
Acceptable	1.81 to 4.50 mm/s
Still permissible	4.51 to 11.2 mm/s
Dangerous	> 11.2 mm/s

Largest machines and turbo machines with a special foundations ( Group T ).

Good	0 to 2.80 mm/s
Acceptable	2.81 to 7.10 mm/s
Still permissible	7.11 to 18.0 mm/s
Dangerous	> 18 mm/s

**13. SENSITIVITY RELATIVE to the reference sensitivity at 80 Hz , according ISO 2954**

Frequency	Normal value	Relative sensitivity	
		Minimum value	Maximum value
10 Hz	1.0	0.8	1.1
20 Hz	1.0	0.9	1.1
40 Hz	1.0	0.9	1.1
80 Hz	1.0	1.0	1.0
160 Hz	1.0	0.9	1.1
500 Hz	1.0	0.9	1.1
1000 Hz	1.0	0.8	1.1

Table 1