

MDT0390ASC-RGB	480 x 128	RGB Interface	TFT Module
(MCT039C12CW480128LML)			
<b>Specification</b>			
Version: 1		Date: 25/01/2018	
<b>Revision</b>			
1	24/01/2018	First issue	

Display Features					
Display Size	3.9"				
Resolution	480 x 128				
Orientation	Landscape				
Appearance	RGB				
Logic Voltage	3.3V				
Interface	RGB				
Brightness	400 cd/m <sup>2</sup>				
Touchscreen	CTP				
Module Size	105.50 x 37.00 x 5.13mm				
Operating Temperature	-20°C ~ +70°C				
Pinout	40 way FFC			Box Quantity	Weight / Display
Pitch	---			---	---

Display Accessories	
Part Number	Description

Optional Variants	
Appearances	Voltage



## Summary

TFT 3.9" is a TN transmissive type color active matrix TFT liquid crystal display that use amorphous silicon TFT as switching devices. This module is a composed of a TFT\_LCD module, It is usually designed for industrial application and this module follows RoHs.

## General Specifications

- Size: 3.9 inch
- Dot Matrix: 480x128 x RGB (TFT) dots
- Module dimension: 105.5(W) x 37.0(H) x 5.13(D) mm
- Active area: 95.04 x 25.34 mm
- Dot pitch: 0.066(W)x 0.198(H) mm
- LCD type: TFT, Normally White, Transmissive
- View Direction: 6 o'clock
- Gray Scale Inversion Direction: 12 o'clock
- Aspect Ratio: Bar Type
- Backlight Type: LED, Normally White
- CTP FW Version:
- With /Without TP: With CTP
- Surface: Glare

\*Color tone slight changed by temperature and driving voltage.



# Interface

## LCM PIN Definition

No.	Symbol	Description	Remark
1	VLED-	Backlight LED Cathode	
2	VLED+	Backlight LED Anode.	
3	GND	System Ground	
4	VCC	Power supply for logic operation	
5~12	R0~R7	Data bus	
13~20	G0~G7	Data bus	
21~28	B0~B7	Data bus	
29	GND	System Ground	
30	DCLK	Pixel clock signal	
31	DISP	Display on/off control	
32	HSYNC	Horizontal Sync signal	Note1
33	VSYNC	Vrtical Sync signal	Note1
34	NC	No connection (Option DE)	Note1
35	NC	No connection	
36	GND	System Ground	
37	NC	No connection (Option XR for RTP)	
38	NC	No connection (Option YD for RTP)	
39	NC	No connection (Option XL for RTP)	
40	NC	No connection (Option YU for RTP)	

Note1: This module default function is for SYNC mode, if this module want change to use DE mode , the FPC have to modify resistive jumper

## CTP PIN Definition

Pin	Symbol	Function	Remark
1	VSS	Ground for analog circuit	
2	VDDT	Power Supply : +3.0V	
3	SCL	SPI Slave mode, chip select, active low / I2C clock input I2C clock input	
4	NC	No connect	
5	SDA	SPI Slave mode, data input / I2C data input and output	
6	NC	No connect	
7	/RST	External Reset, Low is active	
8	NC	No connect	
9	/INT	External interrupt to the host	
10	VSS	Ground for analog circuit	





## Absolute Maximum Ratings

Item	Symbol	Min	Typ	Max	Unit
Operating Temperature	TOP	-20	—	+70	°C
Storage Temperature	TST	-30	—	+80	°C

Note: Device is subject to be damaged permanently if stresses beyond those absolute maximum ratings listed above

- Temp.  $\leq 60^{\circ}\text{C}$ , 90% RH MAX. Temp.  $> 60^{\circ}\text{C}$ , Absolute humidity shall be less than 90% RH at  $60^{\circ}\text{C}$

## Electrical Characteristics

### Operating conditions

Item	Symbol	Condition	Min	Typ	Max	Unit	Remark
Supply Voltage For LCM	VCC	—	3.0	3.3	3.6	V	
Supply Current For LCM	ICC	—	—	15	25	mA	Note 1
Supply Voltage For Touch Logic	VDDT	—	2.8	—	3.3	V	

Note 1 : This value is test for VCC = 3.3V , Ta = 25 °C only

### LED driving conditions

Item	Symbol	MIN	TYP	MAX	Unit	Remark
Forward Current	I <sub>LED</sub>	—	40	—	mA	Note 1,2,3,4
Forward Voltage	V <sub>LED+</sub>	14	15	17	V	
Backlight life time	—	—	50000	—	hr	

Note 1 : There are 1 Groups LED

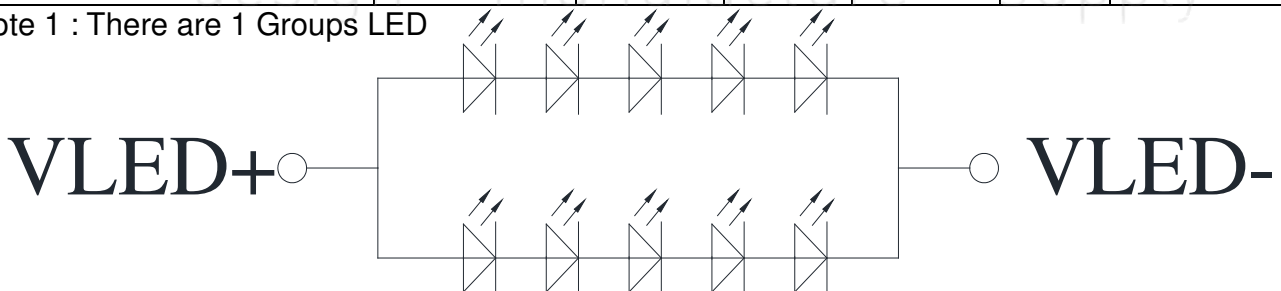

Note 2 : Ta = 25 °C

Note 3 : Brightness to be decreased to 50% of the initial value

Note 4 : The single LED lamp case

## DC CHARATERISTICS

Parameter	Symbol	Rating			Unit	Condition
		Min	Typ	Max		
Low level input voltage	V <sub>IL</sub>	0	-	0.3VCC	V	
High level input voltage	V <sub>IH</sub>	0.7VCC	-	VCC	V	

# Interface Timing

Parallel RGB in SYNC mode  
Horizontal

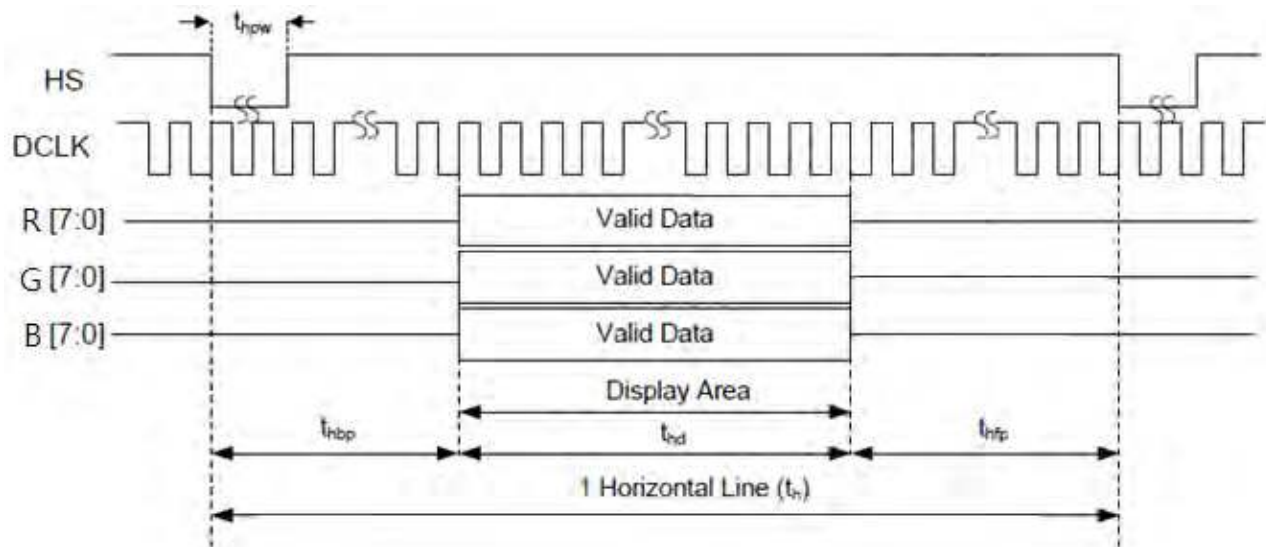

Figure 7.1: Horizontal input timing in Sync mode

Horizontal

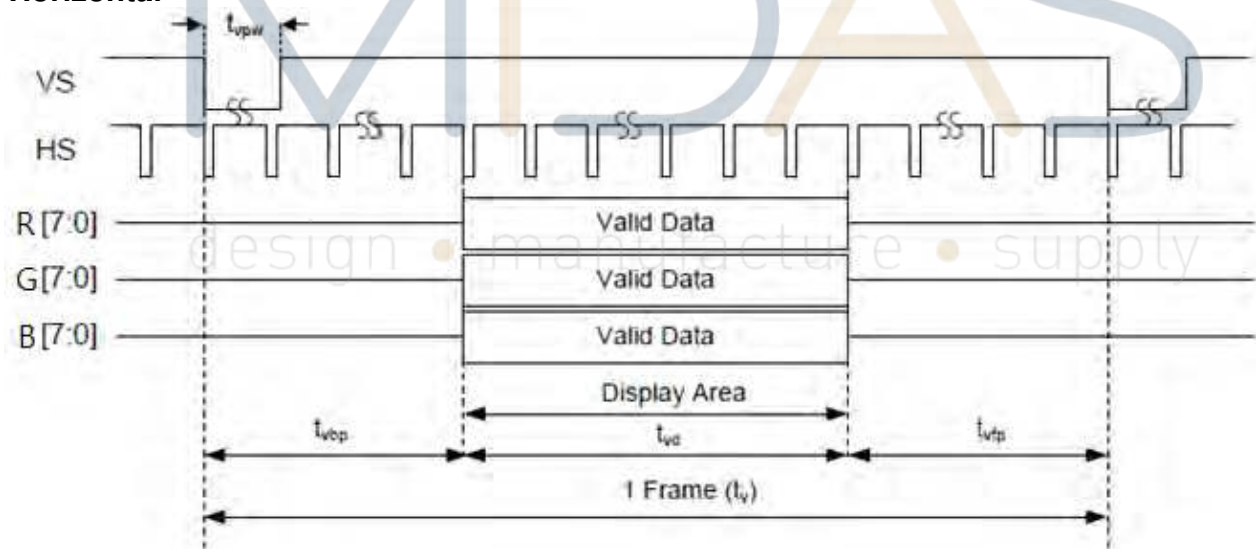

Figure 7.2: Vertical input timing in Sync mode



### Parallel RGB input timing table

Item	Symbol	Min	Typ	Max	Unit	
CLK frequency	Fclk	-	9.05	-	MHz	
DCLK Period	Tclk	-	111	-	ns	
HSYNC	Period Time	Th	510	524	862	DCLK
	Display Period	Thdisp	-	480	-	DCLK
	Back Porch	Thbp	6	16	127	DCLK
	Front Porch	Thfp	24	28	255-	DCLK
	Pulse Width	Thw	11	16	127	DCLK
VSYNC	Period Time	Tv	280	288	526	H
	Display Period	Tvdisp	-	272	-	H
	Back Porch	Tvbp	4	8	127	H
	Front Porch	Tvfp	4	8	127	H
	Pulse Width	Tvw	1	3	20	H

### Touch Panel Information

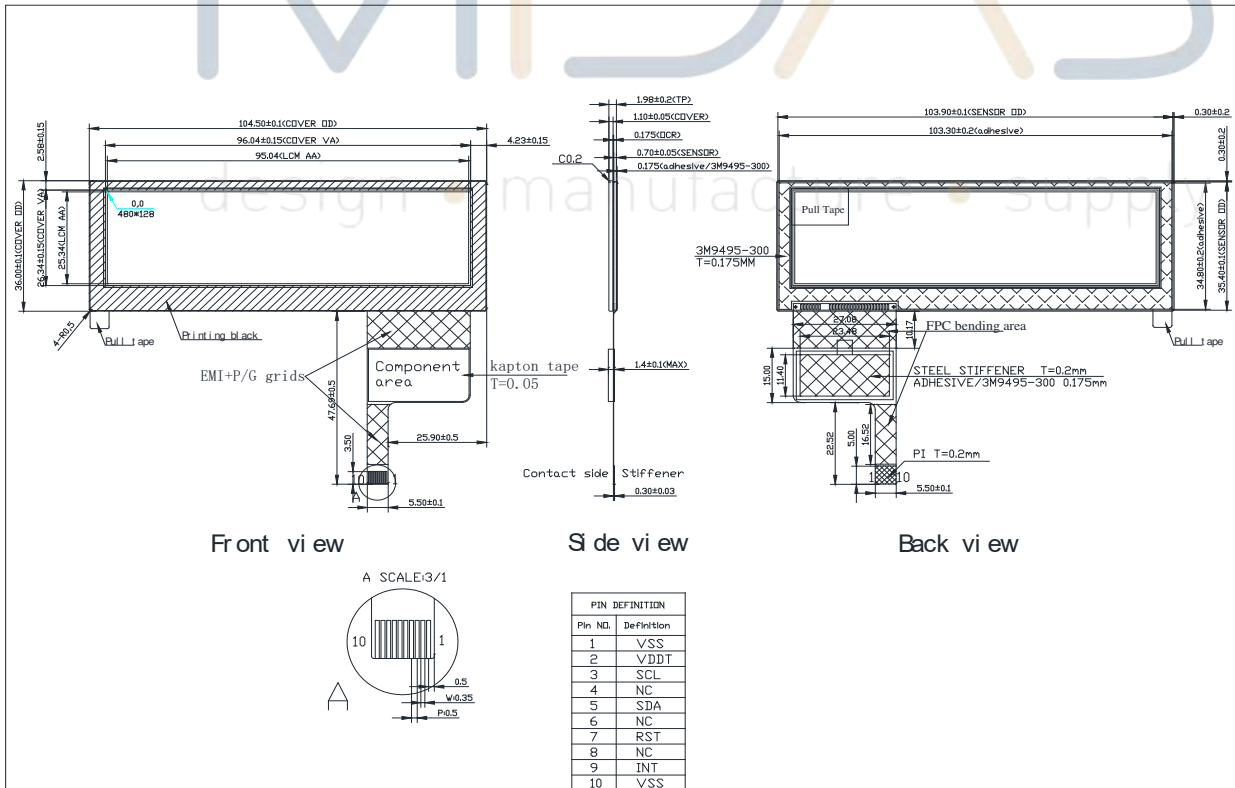

# Optical Characteristics

Item	Symbol	Condition.	Min	Typ.	Max.	Unit	Remark	
Response time	$T_r$	$\theta=0^\circ, \Phi=0^\circ$	-	10	-	ms	Note 3	
	$T_f$		-	15	-			
Contrast ratio	CR	At optimized viewing angle	-	500	-	-	Note 4	
Color Chromaticity	White	$\theta=0^\circ, \Phi=0$	$W_x$	0.269	0.319	0.369	-	Note 2,5
			$W_y$	0.273	0.323	0.373	-	
Viewing angle (Gray Scale Inversion Direction)	Hor.	$CR \geq 10$	$\Theta_R$	-	65	-	Deg	Note 1
			$\Theta_L$	-	65	-		
	Ver.		$\Phi_T$	-	65	-		
			$\Phi_B$	-	50	-		
Brightness	-	-	300	400	-	cd/ m <sup>2</sup>	Center of display	

$T_a=25\pm 2^\circ\text{C}$ , ILED=40mA

Note 1: Definition of viewing angle range

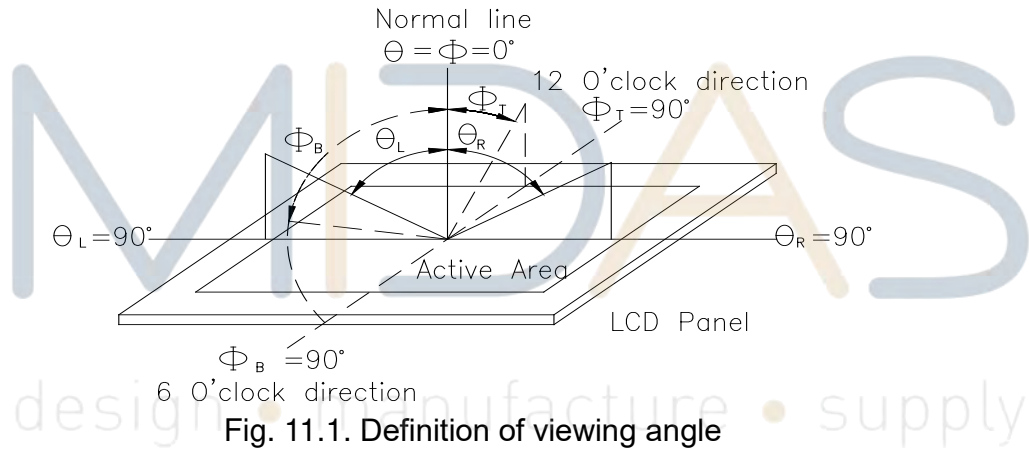

Fig. 11.1. Definition of viewing angle

Note 2: Test equipment setup:

After stabilizing and leaving the panel alone at a driven temperature for 10 minutes, the measurement should be executed. Measurement should be executed in a stable, windless, and dark room. Optical specifications are measured by Topcon BM-7orBM-5 luminance meter 1.0° field of view at a distance of 50cm and normal direction.

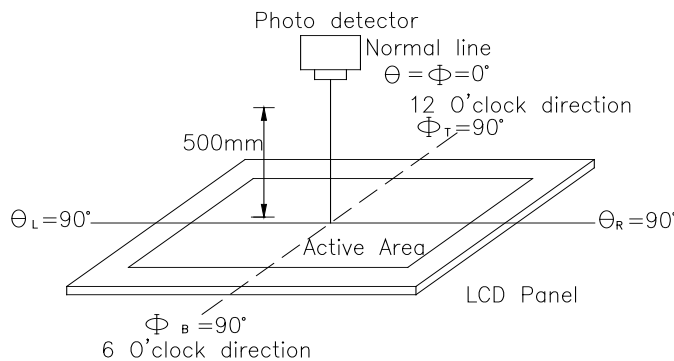

Fig. 11.2. Optical measurement system setup





Note 3: Definition of Response time:

The response time is defined as the LCD optical switching time interval between "White" state and "Black" state. Rise time,  $T_r$ , is the time between photo detector output intensity changed from 90% to 10%. And fall time,  $T_f$ , is the time between photo detector output intensity changed from 10% to 90%

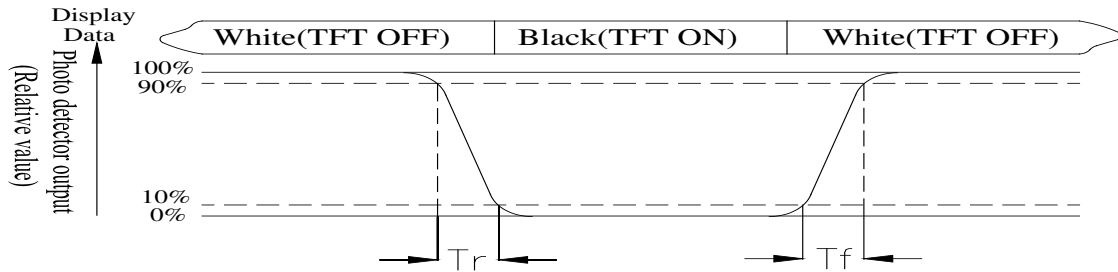

Note 4: Definition of contrast ratio:

The contrast ratio is defined as the following expression.

$$\text{Contrast ratio (CR)} = \frac{\text{Luminance measured when LCD on the "White" state}}{\text{Luminance measured when LCD on the "Black" state}}$$

Note 5: White  $V_i = V_{i50} \pm 1.5V$

Black  $V_i = V_{i50} \pm 2.0V$

"±" means that the analog input signal swings in phase with VCOM signal.

"±" means that the analog input signal swings out of phase with VCOM signal.

The 100% transmission is defined as the transmission of LCD panel when all the input terminals of module are electrically opened.

Note 6: Definition of color chromaticity (CIE 1931)

Color coordinates measured at the center point of LCD

Note 7: Measured at the center area of the panel when all the input terminals of LCD panel are electrically opened.



# Reliability

Content of Reliability Test (Wide temperature, -20°C~70°C)

Environmental Test			
Test Item	Content of Test	Test Condition	Note
High Temperature storage	Endurance test applying the high storage temperature for a long time.	80°C 200hrs	2
Low Temperature storage	Endurance test applying the low storage temperature for a long time.	-30°C 200hrs	1,2
High Temperature Operation	Endurance test applying the electric stress (Voltage & Current) and the thermal stress to the element for a long time.	70°C 200hrs	—
Low Temperature Operation	Endurance test applying the electric stress under low temperature for a long time.	-20°C 200hrs	1
High Temperature/ Humidity Operation	The module should be allowed to stand at 60°C,90%RH max	60°C,90%RH 96hrs	1,2
Thermal shock resistance	The sample should be allowed stand the following 10 cycles of operation  <div style="text-align: center;"> <p style="margin: 0;">-20°C    25°C    70°C</p> <p style="margin: 0;">30min    5min    30min</p> <p style="margin: 0;">1 cycle</p> </div>	-20°C/70°C 10 cycles	—
Vibration test	Endurance test applying the vibration during transportation and using.	Total fixed amplitude : 3 1.5mm Vibration Frequency : 10~55Hz One cycle 60 seconds to 3 directions of X,Y,Z for Each 15 minutes	3
Static electricity test	Endurance test applying the electric stress to the terminal.	VS=±600V(contact) ,±800v(air), RS=330Ω CS=150pF 10 times	—

Note1: No dew condensation to be observed.

Note2: The function test shall be conducted after 4 hours storage at the normal Temperature and humidity after remove from the test chamber.

Note3: The packing have to including into the vibration testing.

