

HC-23768-000

SHT 1.1

NOTE:

LOCATED FROM TWO SURFACES FOR CUSTOMER CONVENIENCE. ONLY APPLICABLE FROM ONE SURFACE, NOT TO BE USED TOGETHER. HORIZONTAL LOCATION FOR TERMINAL CENTERED TO $\pm 0,17$ [.007].

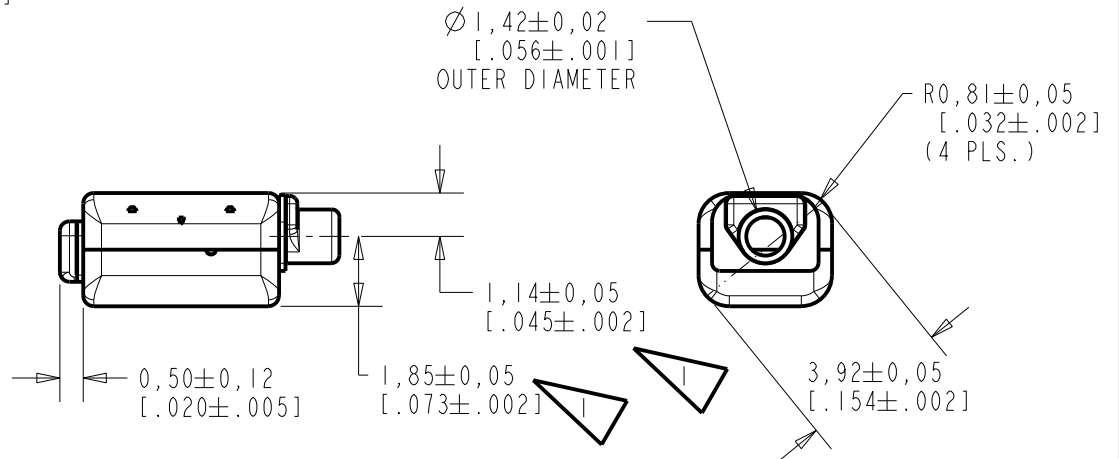
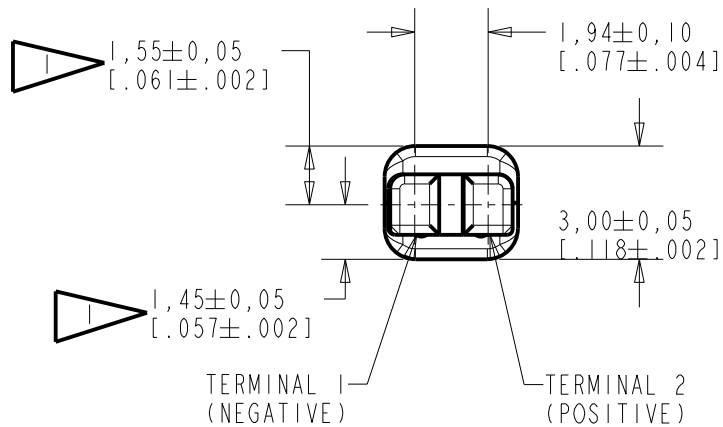
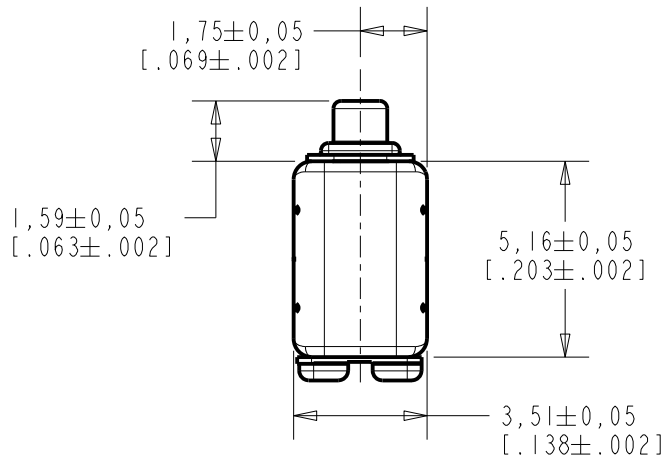

SCALE 2:1

NOMINAL WEIGHT
.23 GRAMS

DIMENSIONS IN MILLIMETERS [INCHES]

Revision	C.O. #	Implementation Date	RELEASE LEVEL	REVISION
C	C10112180	2-28-11	Active	C
B	C10103946	2-20-06		
A	C10103365	11-29-05		

SCALE: 5:1		DR. BY	DATE
DO NOT SCALE DRAWING		AB	11-29-05
TITLE: RECEIVER		CK. BY	DATE
OUTLINE DRAWING		GJP	12-5-05
HC-23768-000		APP. BY	DATE
SHT 1.1		GJP	12-5-05

KNOWLES ELECTRONICS
ITASCA, ILLINOIS U.S.A.

DESCRIPTION

NO DAMPING

HC-23768-000
SHEET 2.1

THE HC-23768-000 IS A MAGNETIC BALANCED ARMATURE RECEIVER INTENDED FOR USE IN ITC AND CIC HEARING INSTRUMENTS. THE HC FAMILY OFFERS 6 dB HIGHER OUTPUT LEVELS IN THE SAME SIZE PACKAGE AS THE FC FAMILY. ALL HC UNITS HAVE SHOCK PROTECTION. THIS MODEL HAS MEDIUM-LOW IMPEDANCE AND IS UNDAMPED.

NOTE: SPECIFICATIONS FOLLOWED BY AN ASTERISK (*) ARE 100% TESTED.

CONSTANT VOLTAGE DRIVE RESPONSE

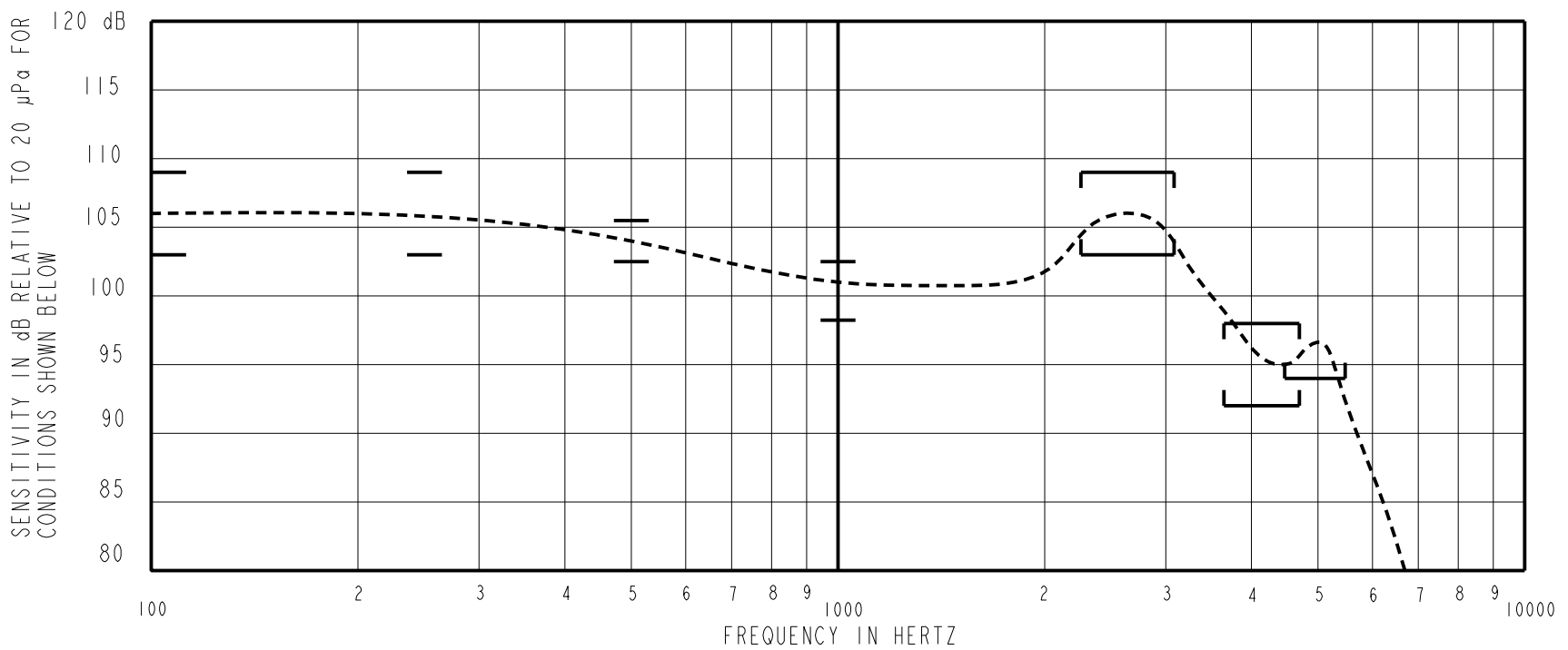

ACOUSTICAL

SENSITIVITY*
DEVICE WILL PRODUCE THE SPL LISTED BELOW WITH THE TEST CONDITIONS DESCRIBED IN TABLE 3. NOMINAL SENSITIVITY AT 1 kHz IS dB RELATIVE TO 20µPa. ALL OTHER VALUES IN dB RELATIVE TO THE SENSITIVITY AT 1 kHz.

FREQUENCY (Hz)	MINIMUM	NOMINAL	MAXIMUM
100	+2.0	+5.0	+8.0
250	+2.0	+5.0	+8.0
500	+1.5	+3.0	+4.5
1000	-1.5	101.0	+1.5
2300-3100 PEAK	+2.0	+5.0	+8.0
3680-4720 VALLEY	-9.0	-6.0	-3.0
4500-5500 PEAK	-7.0	---	---

TABLE 1.

TOTAL HARMONIC DISTORTION*
DEVICE WILL NOT EXCEED TOTAL HARMONIC DISTORTION LEVELS LISTED BELOW.

FREQUENCY (Hz)	DRIVE (V RMS)	DC BIAS (MA)	LIMIT (%)
900	0.238 V	0	5
1350	0.238 V	0	5
500	0.671 V	0	10

TABLE 2.

TEST CONDITIONS

NOMINAL SOURCE VOLTAGE	0.238 Vrms, 0 Vdc BIAS
SOURCE IMPEDANCE	< 1 Ω
TUBING	10 mm (.394) LONG, 1 mm (.039) ID.
COUPLER CAVITY	2 CC SIMULATED ANSI S3.7 TYPE HA-3, (IEC 60318-5)

TABLE 3.

POLARITY *
POSITIVE SIGNAL APPLIED TO TERMINAL 2 WILL PRODUCE A DECREASE IN SOUND PRESSURE AT THE SOUND OUTLET.

ELECTRICAL

DC RESISTANCE	83Ω ±10%	*
IMPEDANCE @ 500 Hz	120Ω ±15%	*
IMPEDANCE @ 1 kHz	205Ω ±20%	*
INDUCTANCE @ 500Hz	35mH ±15%	
CAPACITANCE @ 10 MHz	6pF ±20%	

TABLE 4.

ISOLATION: THE CASE WILL BE ELECTRICALLY ISOLATED FROM THE COIL CIRCUIT*

MAGNETIC RADIATION
WORST CASE: FIELD WILL BE LESS THAN LEVEL STATED BELOW AT AMPLIFIER CLIPPING (.920 V).
134 dB re 1µA/m
DISTANCE OF 6.3 mm FROM CENTER OF RECEIVER
ANGLE OF 120 DEGREES FROM TUBE

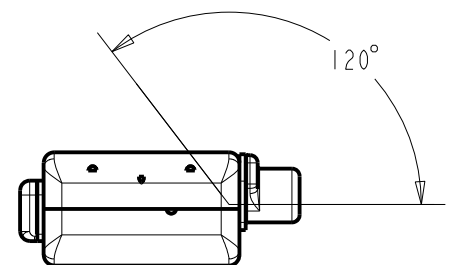

MECHANICAL

PORT LOCATION: 12C

SOLDER TYPE: SAC 305

TEMPERATURE
OPERATING: SENSITIVITY WILL NOT VARY MORE THAN ±1/-3 dB FROM -17°C TO 63°C
STORAGE: -40°C TO 63°C

RELIABILITY
UNITS WILL SURVIVE ANY OF THE FOLLOWING ACCELERATED LIFE TESTS, REPORT AVAILABLE FROM QA DEPARTMENT

HALT TEST (8 WEEKS, 63°C, 95% RH, 0.83V, 500 Hz SIGNAL)
HIGH TEMPERATURE STORAGE (63°C, 72 HOURS)
LOW TEMPERATURE STORAGE (-40°C, 72 HOURS)
DAMP HEAT CYCLING (ALTERNATE 25°C TO 63°C, 93% RH, 20 CYCLES)
THERMAL SHOCK (-40°C TO 63°C, 5 CYCLES)
SOLDER/DESOLDER CYCLING (5 CYCLES)
SOLDER PAD STRENGTH (STRENGTH > 1.8 LBS.)
STRESS TEST (4.45 Vrms AT 2700 Hz SIGNAL, 1 HOUR)
MECHANICAL SHOCK
LEAK TEST AFTER AGING (NO LEAK AFTER ANY OF THE ABOVE TESTS)

Revision	C.O. #	Implementation Date	RELEASE LEVEL	REVISION
C	C10112180	2-28-11	Active	C
B	C10103946	2-20-06		
A	C10103365	11-29-05		

KNOWLES ELECTRONICS
ITASCA, ILLINOIS U.S.A.

WHEN TEST LIMITS ARE USED TO ESTABLISH INCOMING INSPECTION ACCEPTANCE/REJECTION CRITERIA, CORRELATION OF TEST EQUIPMENT WITH KNOWLES IS ALSO REQUIRED FOR ELIMINATION OF EQUIPMENT AND TEST METHOD VARIATION

TITLE: **RECEIVER**
PERFORMANCE SPECIFICATION

HC-23768-000
SHT 2.1

DR. BY	DATE
AB	11-29-05
CK. BY	DATE
GJP	12-5-05
APP. BY	DATE
GJP	12-5-05