

REF. -49 OPT. SCREW
(WHERE APPLICABLE)

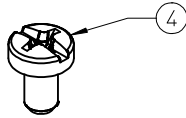

REF. -50 OPT. SCREW
(WHERE APPLICABLE)

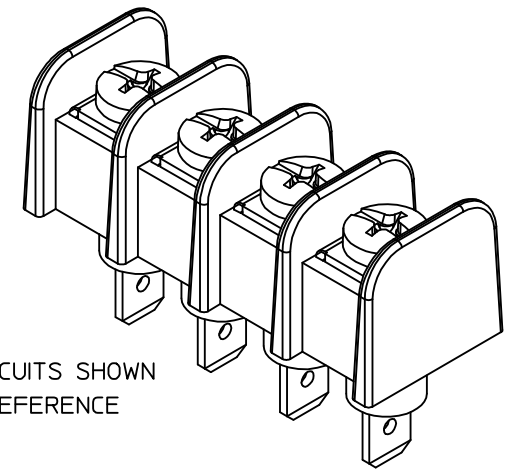
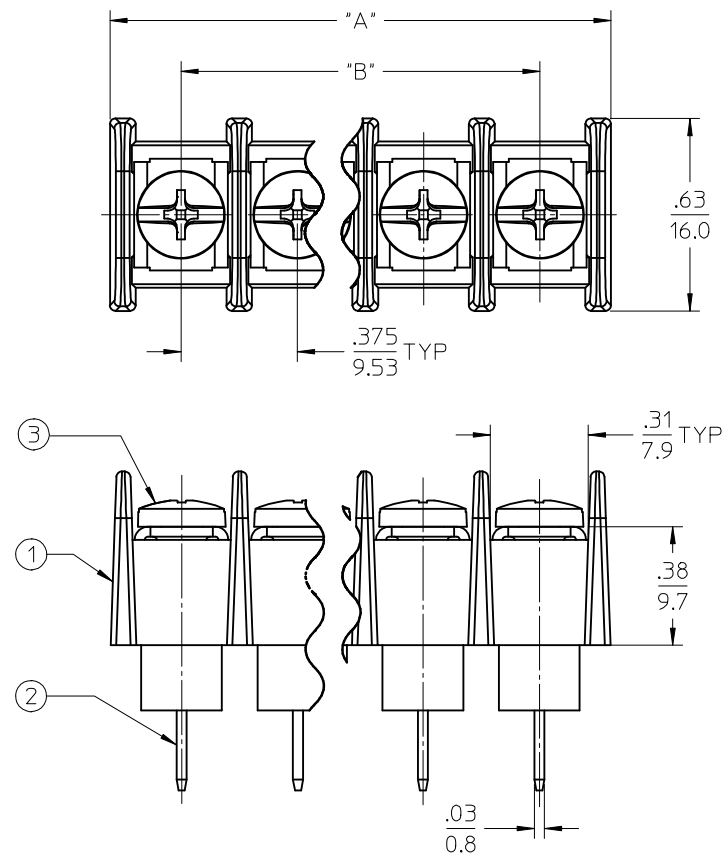
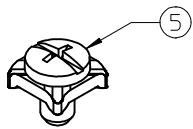

4 CIRCUITS SHOWN
AS REFERENCE

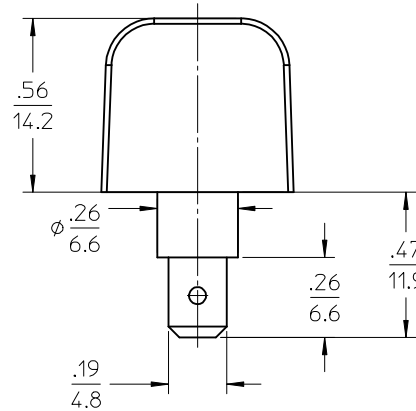

PART NUMBER LEGEND

71-9-XX-XX

SERIES

TERMINAL STYLE

CIRCUIT QTY (2 TO 26)

OPTION (-49 BRASS,PHIL/SLOT SCREW)

(-50 CLAMP WASHER,PHIL/SLOT SCREW)

(-C NO MOUNTING ENDS)

NOTES:

1. MATERIAL: SEE TABLE.
2. FINISHES: SEE TABLE.
3. PRODUCT SPECIFICATION: PS-38710-001
4. "XX" REFERS TO NUMBER OF CIRCUITS.
5. ASSEMBLY IS RoHS COMPLIANT.

ITEM	QTY	DESCRIPTION	MATERIAL	FINISH
5	XX	#6-32 PH/SLOTTED SCREW W/WSHR (OPTION -50)	STEEL	ZINC
4	XX	#6-32 PH/SLOTTED SCREW (OPTION -49)	BRASS	NICKEL
3	XX	#6-32 PH/SLOTTED SCREW (STANDARD)	STEEL	ZINC
2	XX	TERMINAL, WW SN-KT	BRASS	TIN
1	1	INSULATOR	POLYESTER (PBT)	BLACK

RELEASED
EC NO: IPG2016-0008
DRAWN: SVMURTHY 2015/06/30
CHKD: RSTONE 2015/06/30
APPR: JFMURPHY 2016/07/11
REV A

QUALITY SYMBOLS
▽/0
▽/0
▽/0

	GENERAL TOLERANCES (UNLESS SPECIFIED)	
	mm	INCH
4 PLACES	± ---	± ---
3 PLACES	± ---	± .005
2 PLACES	± 0.13	± .01
1 PLACE	± 0.3	± ---
0 PLACE	± ---	± ---

ANGULAR ± 2°
DRAFT WHERE APPLICABLE
MUST REMAIN WITHIN DIMENSIONS

DIMENSION STYLE	
IN	MM
DRAWN BY	DATE
SVMURTHY	2015/06/30
CHECKED BY	DATE
RSTONE	2015/06/30
APPROVED BY	DATE
JFMURPHY	2016/07/11

MATERIAL NO.
SEE SHEET 2

SCALE	DESIGN UNITS	THIRD ANGLE PROJECTION
2:1	INCH	☉
TITLE 9.53MM [.375"] SR BTS QUICK CONN. NO MTG		
DOCUMENT NO. SD-38711-6802		SHEET NO. 1 OF 2

molex

THIS DRAWING CONTAINS INFORMATION THAT IS PROPRIETARY TO MOLEX INCORPORATED AND SHOULD NOT BE USED WITHOUT WRITTEN PERMISSION

# OF CIRCUITS "XX"	DIM. "A"		DIM. "B"	
	in	mm	in	mm
02	.83	21.1	.375	9.53
03	1.21	30.7	.750	19.05
04	1.58	40.1	1.125	28.58
05	1.96	49.8	1.500	38.10
06	2.33	59.2	1.875	47.63
07	2.71	68.8	2.250	57.15
08	3.08	78.2	2.625	66.68
09	3.46	87.9	3.000	76.20
10	3.83	97.3	3.375	85.73
11	4.21	107	3.750	95.25
12	4.58	116	4.125	104.78
13	4.96	126	4.500	114.30
14	5.33	135	4.875	123.83
15	5.71	145	5.250	133.35
16	6.08	154	5.625	142.88
17	6.46	164	6.000	152.40
18	6.83	173	6.375	161.93
19	7.21	183	6.750	171.45
20	7.58	193	7.125	180.98
21	7.96	202	7.500	190.50
22	8.33	212	7.875	200.03
23	8.71	221	8.250	209.55
24	9.08	231	8.625	219.08
25	9.46	240	9.000	228.60
26	9.83	250	9.375	238.13

RELEASED EC NO: IFC2016-0008 DRWN: SVMURTHY 2015/06/30 CHKD: RSTONE 2015/06/30 APPR: JFMURPHY 2016/07/11	DESCRIPTION REV A	QUALITY SYMBOLS	GENERAL TOLERANCES (UNLESS SPECIFIED)	DIMENSION STYLE	SCALE	DESIGN UNITS	THIRD ANGLE PROJECTION
		$\nabla F/0$ $\nabla E/0$ $\nabla D/0$	mm INCH 4 PLACES ± --- ± --- 3 PLACES ± --- ± .005 2 PLACES ± 0.13 ± .01 1 PLACE ± 0.3 ± --- 0 PLACE ± --- ± ---	IN/MM	2:1	INCH	9.53MM [.375"] SR BTS QUICK CONN. NO MTG
		ANGULAR ± 2 ° DRAFT WHERE APPLICABLE MUST REMAIN WITHIN DIMENSIONS	DRAWN BY DATE SVMURTHY 2015/06/30 CHECKED BY DATE RSTONE 2015/06/30 APPROVED BY DATE JFMURPHY 2016/07/11	MATERIAL NO. 387115302	DOCUMENT NO. SD-38711-6802	SHEET NO. 2 OF 2	
		THIS DRAWING CONTAINS INFORMATION THAT IS PROPRIETARY TO MOLEX INCORPORATED AND SHOULD NOT BE USED WITHOUT WRITTEN PERMISSION				molex	