

ACCELERATE[®]

SLIM, DIRECT ATTACH CABLE ASSEMBLIES

(0.635 mm) .025" PITCH

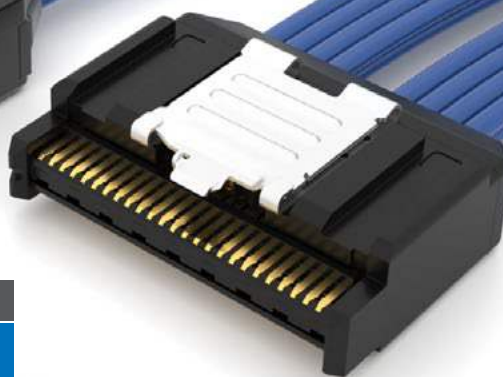

NRZ

28
G b p s

PAM4

56
G b p s

FEATURES & BENEFITS

- Slimmest cable assembly in the industry - 7.6 mm width
- High-density 2-row design
- 8, 16 and 24 differential pair configurations
- 34 AWG, 100 Ω Eye Speed[®] ultra low skew twinax cable
- Multiple wiring options including reverse polarity
- Mating board level socket (ARF6 Series) features standard rugged weld tabs for increased stability on the PCB
- Rugged metal latching and shielding
- Supports 56 Gbps PAM4 (28 Gbps NRZ) applications
- Utilizes Samtec's Flyover[®] Technology to simplify board layout and extend signal reach

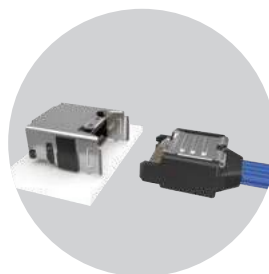

Right-angle available.
Visit [samtec.com?ARF6-RA](https://www.samtec.com?ARF6-RA)
for specifications.



Two rows of high-density
contacts directly
soldered to the cable

KEY SPECIFICATIONS

PITCH	CABLE	SIGNAL ROUTING	INSULATOR MATERIAL	CONTACT MATERIAL	PLATING	OPERATING TEMP RANGE
(0.635 mm) .025"	34 AWG Eye Speed [®] ultra low skew twinax	100 Ω Differential	Black LCP	Copper Alloy	Au or Sn over 50 μ " (1.27 μ m) Ni	-40 $^{\circ}$ C to +125 $^{\circ}$ C

(0.635 mm) .025" • SLIM CABLE & SOCKET

ARC6	NO OF PAIRS	CABLE LENGTH	END 1	END 2	WIRING OPTION	CABLE TYPE
	-08 -16 -24	-“XX.X” = Length in Inches 03.0" (76.2 mm) minimum	-LU = Latch Up	-LU = Latch Up -LD = Latch Down	-2 = Pin 1 to Pin 2 (End 2 -LD option only) -3 = Pin 1 to Pin N-1 (End 2 -LU option only) -2R = Pin 1 to Pin 2 Reversed Polarity (End 2 -LD option only) 0.60" (152.4 mm) min. cable length -3R = Pin 1 to Pin N-1 Reversed Polarity (End 2 -LU option only) 0.60" (152.4 mm) min. cable length	-1 = 34 AWG 100 Ω Eye Speed®

ARC6
Board Mates:
ARF6

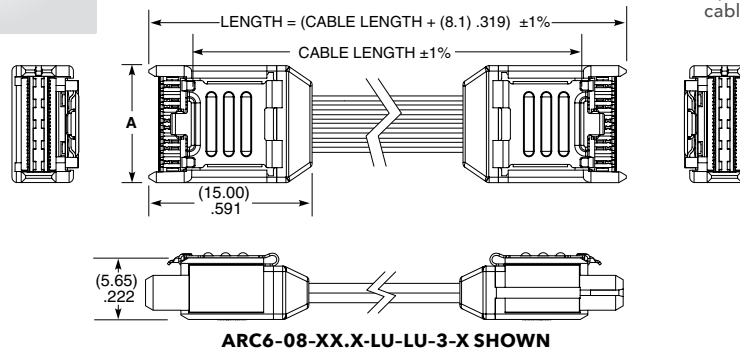

NO. OF PAIRS	A	N	N-1
-08	(10.90) .429	26	25
-16	(18.52) .729	50	49
-24	(26.14) 1.029	74	73

Notes:
Cable lengths longer than 40.00" (1 meter) are not supported with S.I. test data.

View complete specifications at: samtec.com?ARC6

ARF6	NO. OF PAIRS	PLATING	ROW	A	K	"X"R
	-08 -16 -24	-S = 30 μ" (0.76 μm) Gold on contact area, Matte Tin on tail	-D = Double Row	-A = Alignment Pin	-K = Polyimide film Pick & Place Pad	-TR = Tape & Reel -FR = Full Reel Tape & Reel (must order maximum quantity per reel; contact Samtec for quantity breaks)

ARF6
Cable Mates:
ARC6

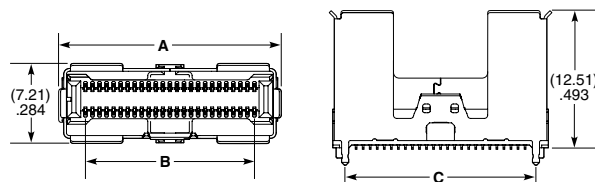
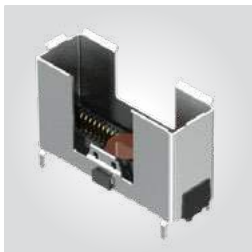

NO. OF PAIRS	A	B	C
-08	(12.46) .491	(7.62) .300	(9.59) .378
-16	(20.08) .791	(15.24) .600	(17.21) .678
-24	(27.70) 1.091	(22.86) .900	(24.83) .978

Notes:
Tape & Reel packaging and K-Dot are standard.

Some sizes, styles and options are non-standard, non-returnable.

View complete specifications at: samtec.com?ARF6