

DUAL AUDIO OPERATIONAL AMPLIFIER

FEATURES

- Supply Voltage ±2V to ±18V
- Low Input Noise Voltage 5nV/√Hz typ. at f=1kHz
- Wide Gain Bandwidth Product 15 MHz typ.
- Low Distortion 0.0005% typ.
- Slew Rate 5V/μs typ.
- Bipolar Technology
- Package Outline SOP8
MSOP8 (TVSP8)*
*meet JEDEC MO-187-DA / thin type
SSOP8
- Internal ESD Protection Human Body Model (HBM) ±2000V typ.
- Wide Temperature Range -40°C to 125°C

APPLICATIONS

- Home Audio
- Car Audio
- Active Filters
- Servo Control Amplifiers
- Headphone Amplifiers

DESCRIPTION

The NJM8080 is dual operational amplifier designed for audio applications. NJM8080 finely refines to every detail from Si-wafer to circuit layout, stick in a thorough improvement in sound quality. The NJM8080 features high resolution and crispy-clear high frequency sound, which can fully perform the digital sound source with loss-less.

NJM8080 features low noise, wide gain-bandwidth, low distortion and high output current, and various reliabilities and conveniences are improved. NJM8080 can widely be used as the standard audio operational amplifier.

RELATED PRODUCT

PRODUCT NAME	FEATURES
NJM8068	3.5nV/√Hz, 0.001%, 6.8V/μs, 19MHz (Low noise, low distortion audio Op-Amp)

EQUIVALENT CIRCUIT

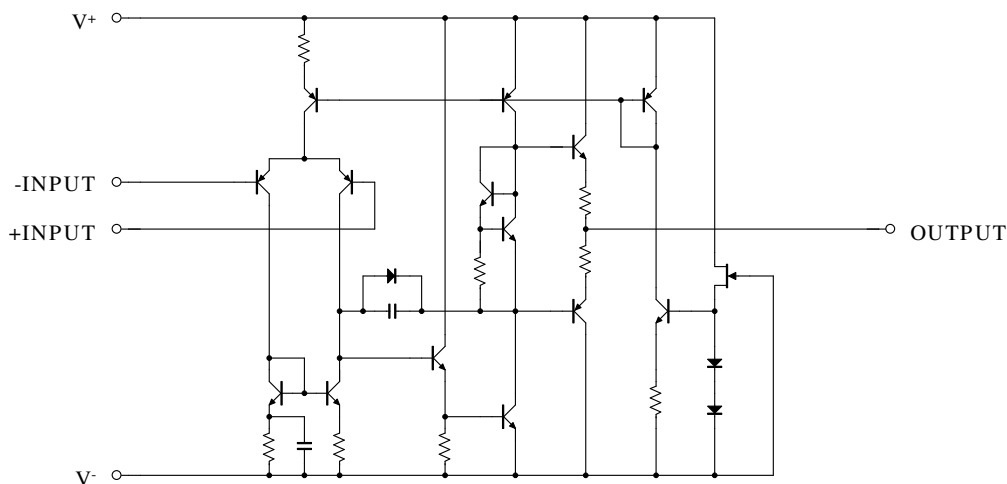

■ PIN CONFIGURATIONS

PRODUCT NAME	NJM8080G	NJM8080RB1	NJM8080V
Package	SOP8	MSOP8 (TVSP8)	SSOP8
Pin Functions			

■ PRODUCT NAME INFORMATION

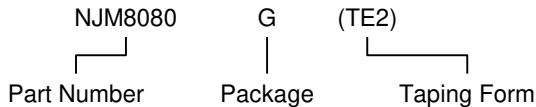

■ ORDER INFORMATION

PRODUCT NAME	PACKAGE	RoHS	HALOGEN-FREE	TERMINAL FINISH	MARKING	WEIGHT (mg)	MOQ (pcs)
NJM8080G	SOP8	Yes	Yes	Pure Sn	8080	88	2500
NJM8080RB1	MSOP8 (TVSP8)	Yes	Yes	Sn2Bi	8080	18	2000
NJM8080V	SSOP8	Yes	Yes	Sn2Bi	8080	42	2000

■ ABSOLUTE MAXIMUM RATINGS

PARAMETER	SYMBOL	RATING	UNIT
Supply Voltage	V^+/V^-	± 18	V
Differential Input Voltage ⁽¹⁾	V_{ID}	± 36	V
Input Voltage ⁽²⁾	V_{IN}	$V^- - 0.3$ to $V^+ + 36$	V
Output Terminal Input Voltage	V_O	$V^- - 0.3$ to $V^+ + 0.3$	V
Power Dissipation ⁽³⁾	P_D	2-Layer / 4-Layer ⁽⁴⁾	
SOP8		690 / 1000	mW
MSOP8 (TVSP8)		510 / 680	
SSOP8	430 / 540		
Storage Temperature Range	T_{stg}	-65 to 150	°C
Maximum Junction Temperature	T_{jmax}	150	°C

■ THERMAL CHARACTERISTICS

PACKAGE	SYMBOL	VALUE	UNIT
Junction-to-Ambient Thermal Resistance	Θ_{ja}	2-Layer / 4-Layer ⁽⁴⁾	
SOP8		181 / 125	°C/W
MSOP8 (TVSP8)		245 / 184	
SSOP8	291 / 231		
Junction-to-Top of Package Characterization Parameter	Ψ_{jt}	2-Layer / 4-Layer ⁽⁴⁾	
SOP8		49 / 43	°C/W
MSOP8 (TVSP8)		51 / 45	
SSOP8	46 / 45		

(1) Differential voltage is the voltage difference between +INPUT and -INPUT.

(2) Input voltage is the voltage should be allowed to apply to the input terminal independent of the magnitude of V^+ .

The normal operation will establish when any input is within the "Common-Mode Input Voltage Range" of electrical characteristics.

(3) Power dissipation is the power that can be consumed by the IC at $T_a = 25^\circ\text{C}$, and is the typical measured value based on JEDEC condition.

(4) 2-Layer: Mounted on glass epoxy board. (76.2×114.3×1.6 mm: based on EIA/JDEC standard, 2-layer FR-4)

4-Layer: Mounted on glass epoxy board. (76.2×114.3×1.6 mm: based on EIA/JDEC standard, 4-layer FR-4), internal Cu area: 74.2 x 74.2 mm

■ POWER DISSIPATION vs. AMBIENT TEMPERATURE

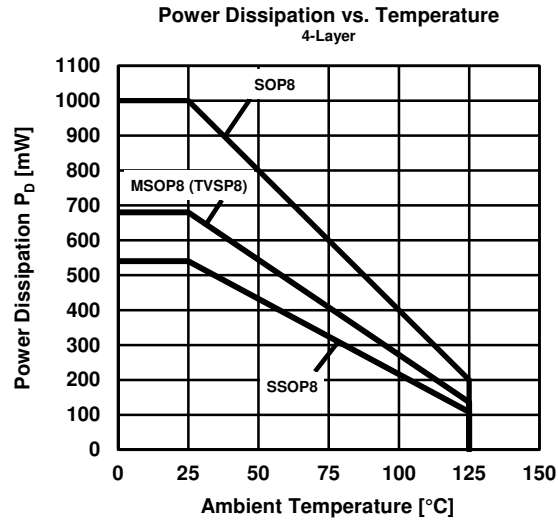
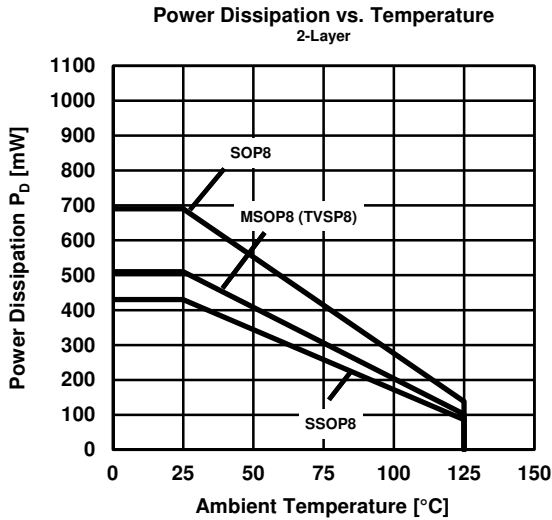

RECOMMENDED OPERATING CONDITIONS

PARAMETER	SYMBOL	CONDITIONS	VALUE	UNIT
Supply Voltage	V^+ / V^-	$T_a = 25^\circ\text{C}$	± 2 to ± 18	V
Operating Temperature Range	T_{opr}		-40 to 125	$^\circ\text{C}$

■ ELECTRICAL CHARACTERISTICS ($V^+ / V^- = \pm 15\text{V}$, $T_a = 25^\circ\text{C}$, unless otherwise noted.)

PARAMETER	SYMBOL	TEST CONDITIONS	MIN	TYP	MAX	UNIT
INPUT/OUTPUT CHARACTERISTICS						
Input Offset Voltage	V_{IO}	$R_S \leq 10\text{k}\Omega$	-	0.3	3	mV
Input Bias Current	I_B		-	100	500	nA
Input Offset Current	I_{IO}		-	5	200	nA
Input Resistance	R_{IN}		-	0.5	-	$\text{M}\Omega$
Open-Loop Voltage Gain	A_V	$R_L \geq 2\text{k}\Omega, V_O = \pm 10\text{V}$	90	110	-	dB
Maximum Output Voltage	V_{OM}	$R_L \geq 2\text{k}\Omega$	± 12	± 13.5	-	V
Common-Mode Input Voltage Range	V_{ICM}		± 12	± 13.5	-	V
Common-Mode Rejection Ratio	CMR	$R_S \leq 10\text{k}\Omega$	80	110	-	dB
POWER SUPPLY						
Supply Voltage Rejection Ratio	SVR	$R_S \leq 10\text{k}\Omega$	80	110	-	dB
Supply Current	I_{SUPPLY}		-	6	9	mA
AC CHARACTERISTICS						
Slew Rate	SR	$R_L \geq 2\text{k}\Omega$	-	5	-	$\text{V}/\mu\text{s}$
Gain Bandwidth Product	GBW	$f = 10\text{kHz}$	-	15	-	MHz
Total Harmonic Distortion + Noise	THD+N	$A_V = 20\text{dB}, V_O = 5\text{V}, R_L = 2\text{k}\Omega, f = 1\text{kHz}$	-	0.0005	-	%
Equivalent Input Noise Voltage	e_n	$f = 1\text{kHz}$	-	5	-	$\text{nV}/\sqrt{\text{Hz}}$

■ TYPICAL CHARACTERISTICS

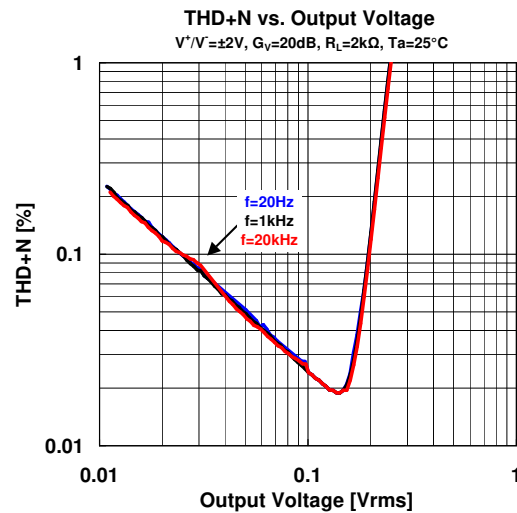
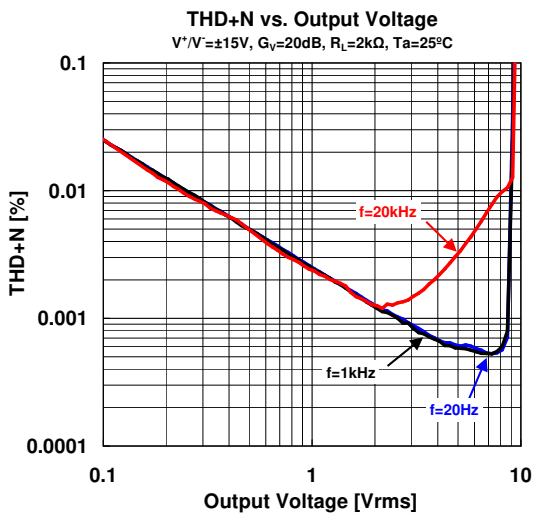
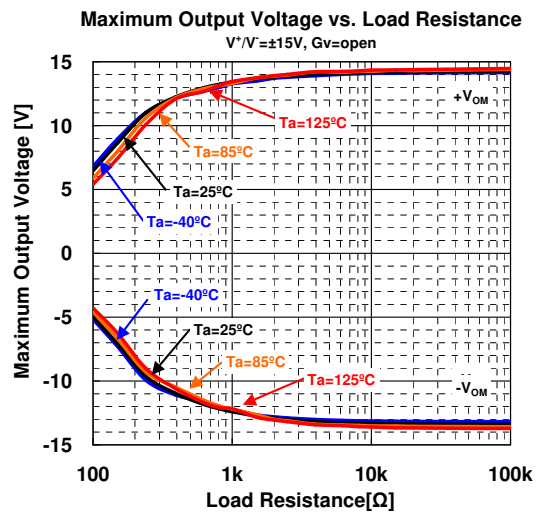
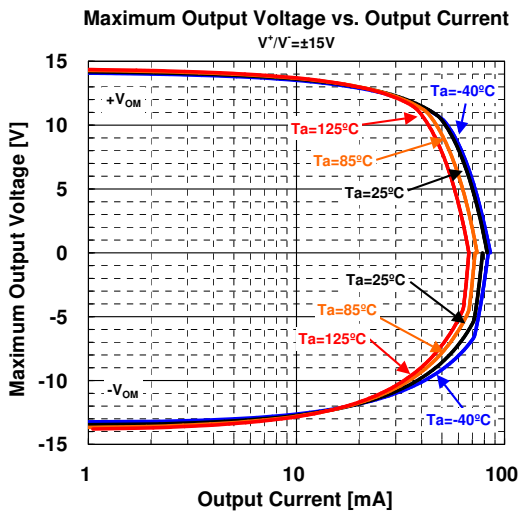
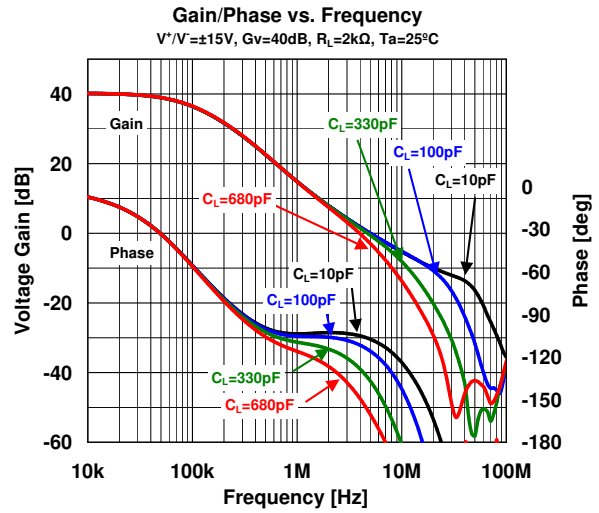
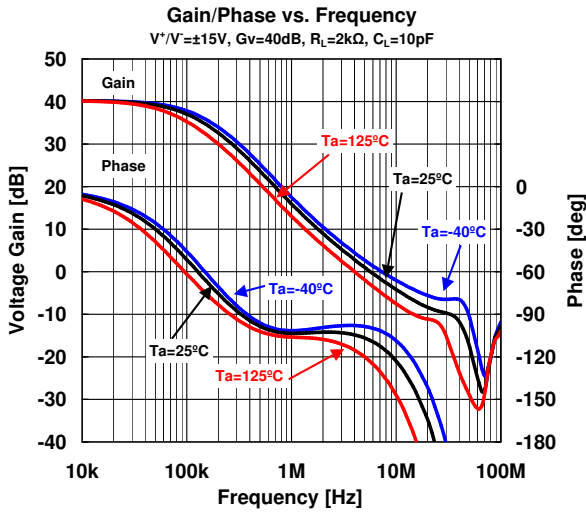

■ TYPICAL CHARACTERISTICS

Maximum Output Voltage Swing vs. Frequency
 $V^+ / V^- = \pm 15V$, $R_L = 2k\Omega$, $T_a = 25^\circ C$

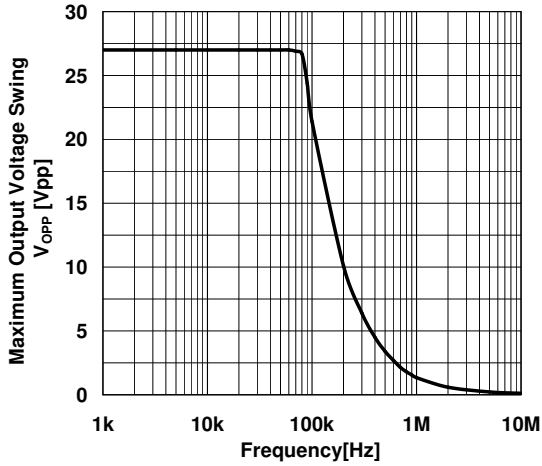

Voltage Noise vs. Frequency
 $V^+ / V^- = \pm 15V$, $G_v = 40dB$, $R_F = 2k\Omega$, $T_a = 25^\circ C$

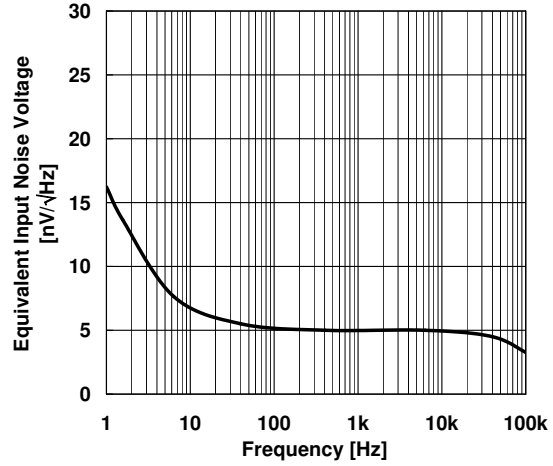

Supply Current vs. Supply Voltage
 $R_L = open$

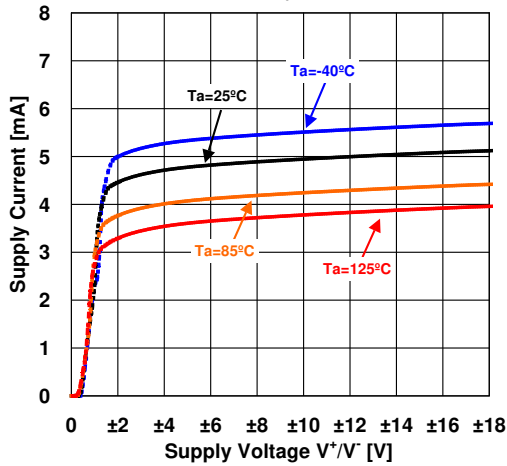

Supply Current vs. Temperature
 $R_L = open$

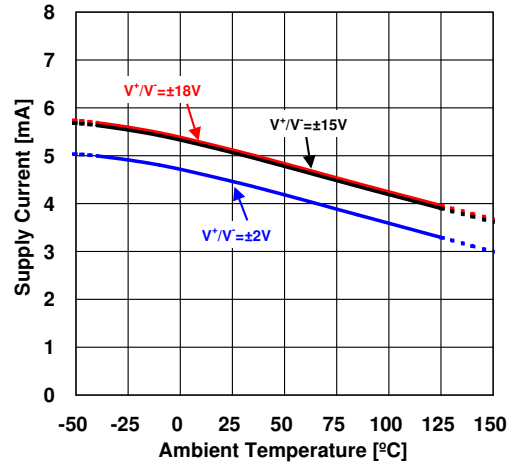

Input Offset Voltage vs. Temperature

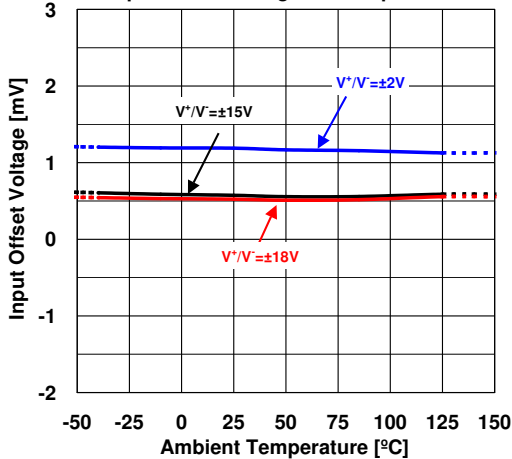

Input Offset Voltage vs. Supply Voltage

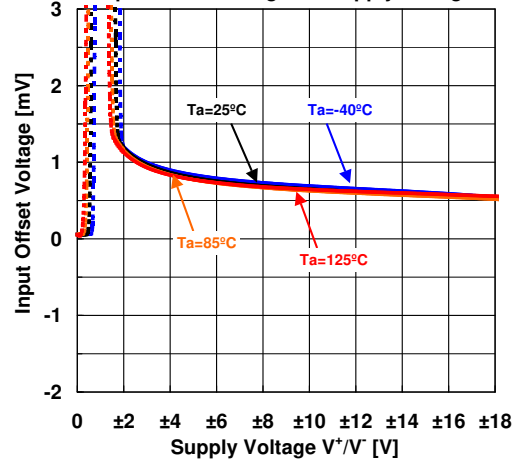

■ TYPICAL CHARACTERISTICS

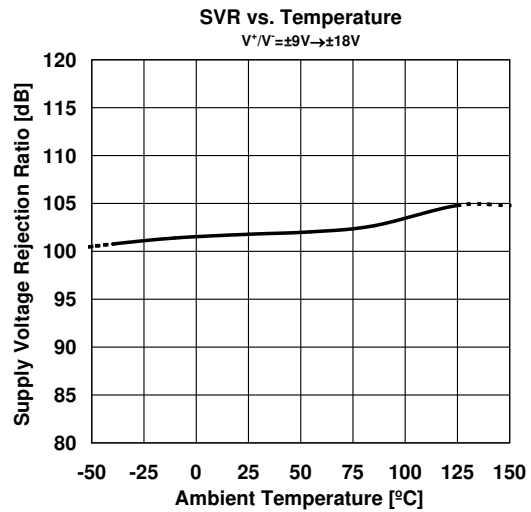
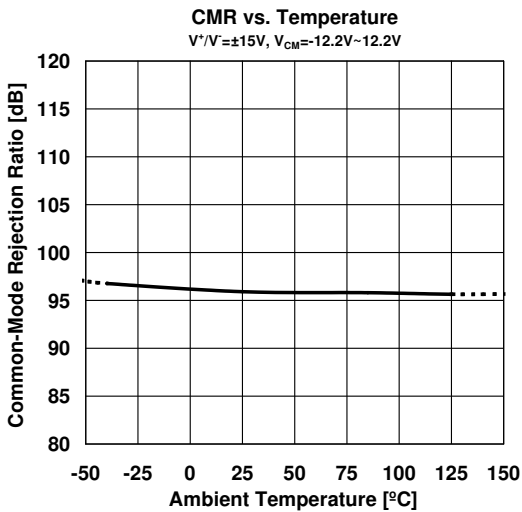
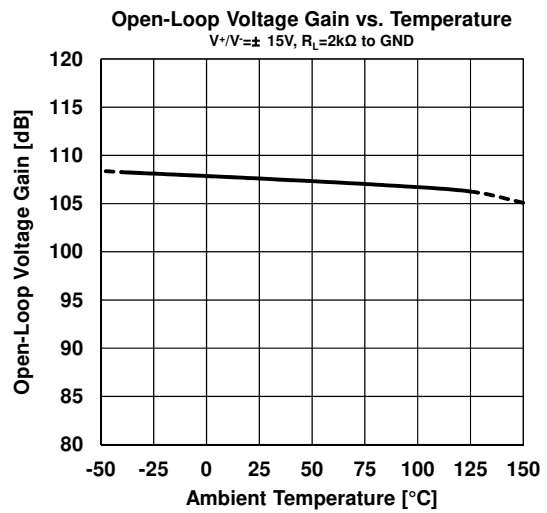
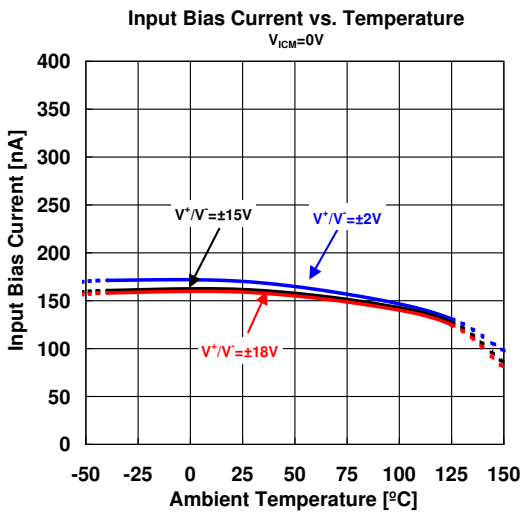
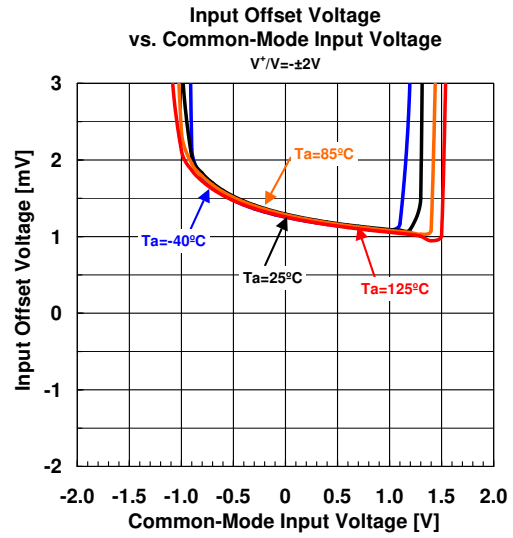
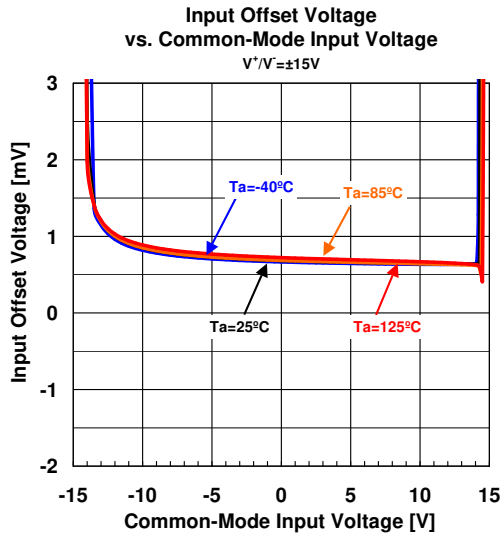

■ TYPICAL CHARACTERISTICS

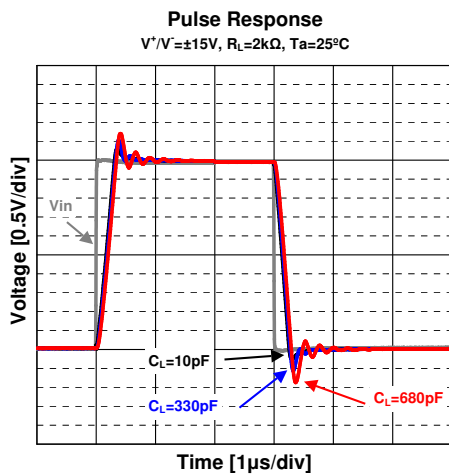
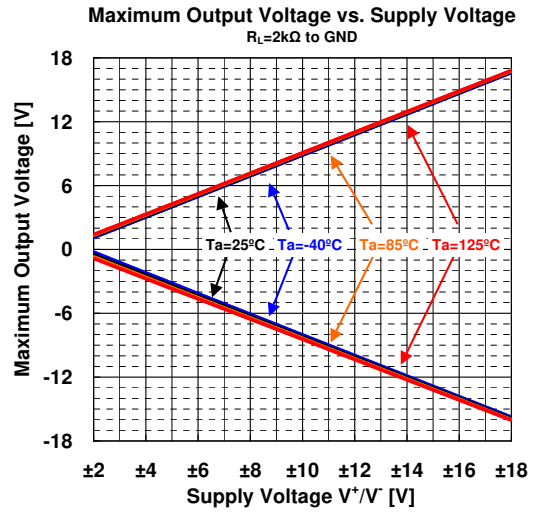
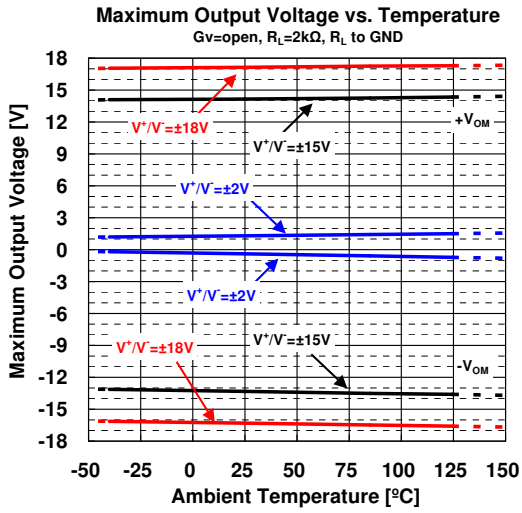

■ TEST CIRCUITS

• I_{SUPPLY}

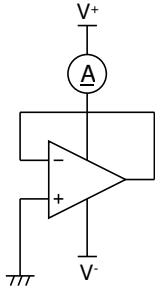

• V_{IO}, CMR, SVR

$R_G=50\Omega, R_F=50k\Omega$

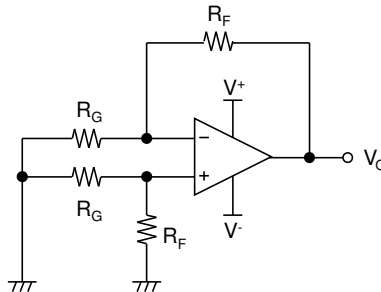

$$V_{IO} = \frac{R_G}{(R_G + R_F)} \times V_O$$

$$CMR = 20 \log \frac{\Delta V_{COM} \left(1 + \frac{R_F}{R_G}\right)}{\Delta V_O}$$

$$SVR = 20 \log \frac{\Delta V_S \left(1 + \frac{R_F}{R_G}\right)}{\Delta V_O}$$

$V_S = V^+ - V^-$

• V_{OH}, V_{OL}

$V_{OH}: V_{in+} = 1V, V_{in-} = -1V$

$V_{OL}: V_{in+} = -1V, V_{in-} = 1V$

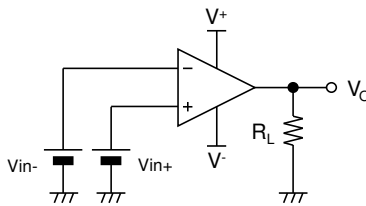

• SR

$R_L=2k\Omega$

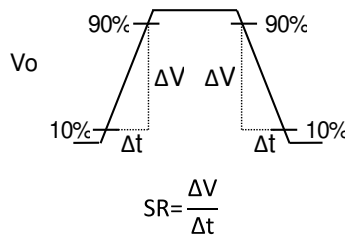
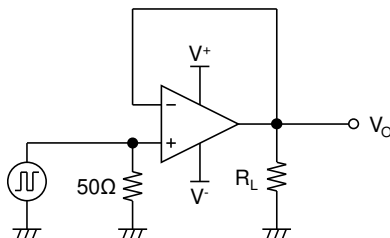

SOP8

Unit: mm

PACKAGE DIMENSIONS

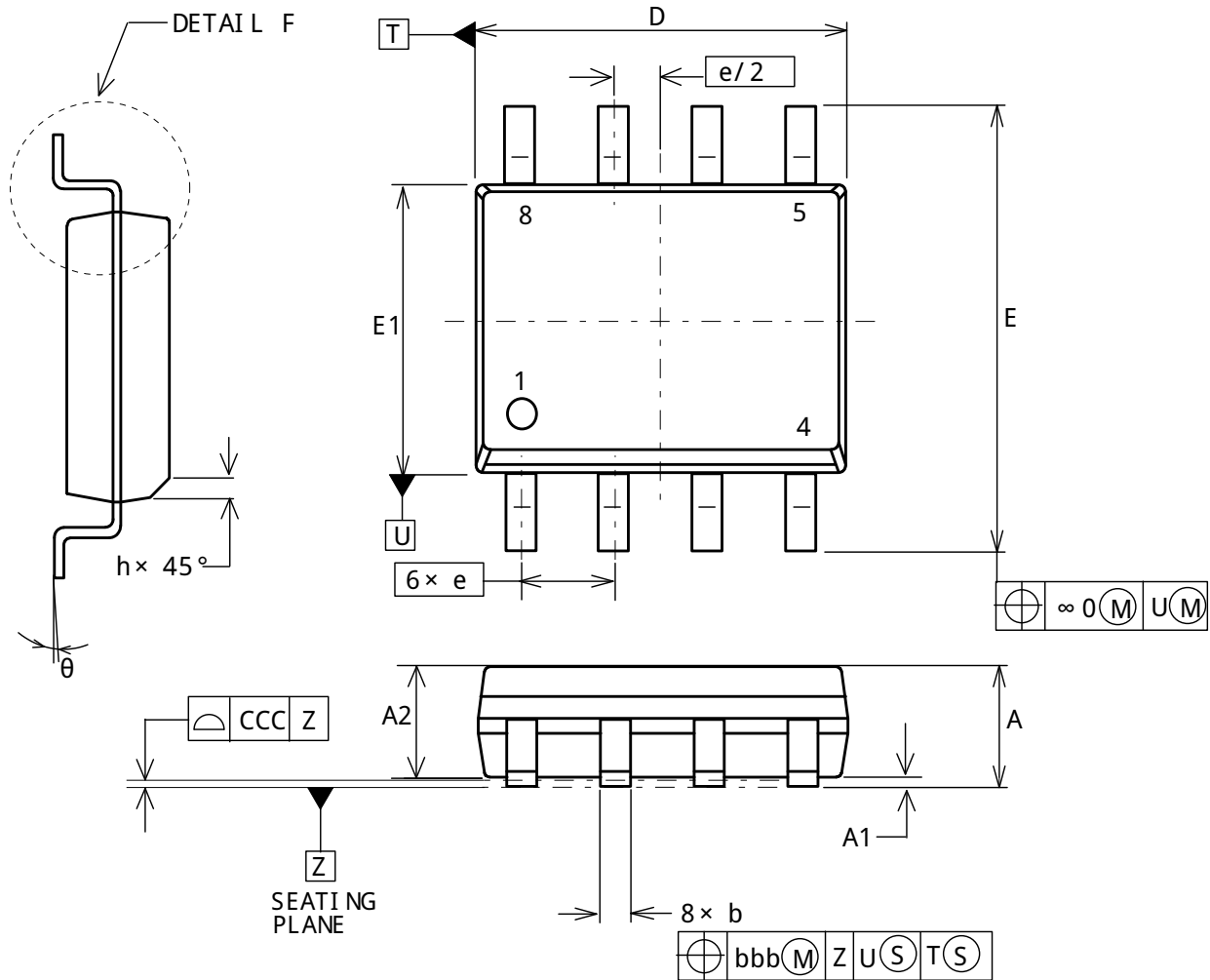

DESCRIPTION	SYMBOL	INCH			MILLIMETER		
		MIN	NCM	MAX	MIN	NCM	MAX
TOTAL THICKNESS	A	.053		.069	1.35		1.75
STAND OFF	A1	.004		.010	0.10		0.25
MOLD THICKNESS	A2	.049		-	1.25		-
LEAD WIDTH	b	.014		.019	0.35		0.49
L/F THICKNESS	C	.007		.010	0.19		0.25
BODY SIZE	D	.189		.197	4.80		5.00
	E1	.150		.157	3.80		4.00
	E	.228		.244	5.80		6.20
LEAD PITCH	e	.050 BSC			1.27 BSC		
	L	.015		.049	0.40		1.25
	h	.010		.020	0.25		0.50
	θ	0°		7°	0°		7°
	$\theta 1$	5°		15°	5°		15°
	$\theta 2$	2°	7°	12°	2°	7°	12°
LEAD EDGE OFFSET	∞O	.010			0.25		
LEAD OFFSET	bbb	.010			0.25		
COPLANARITY	CCC	.004			0.10		

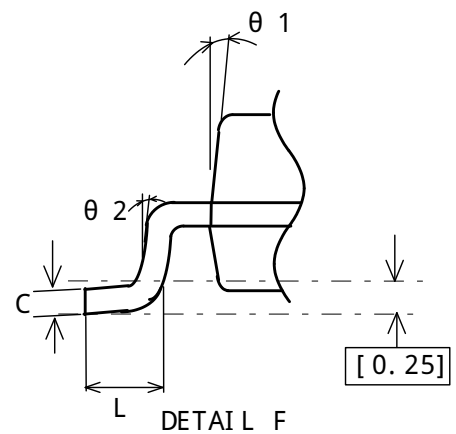

SOP8

Unit: mm

■ EXAMPLE OF SOLDER PADS DIMENSIONS

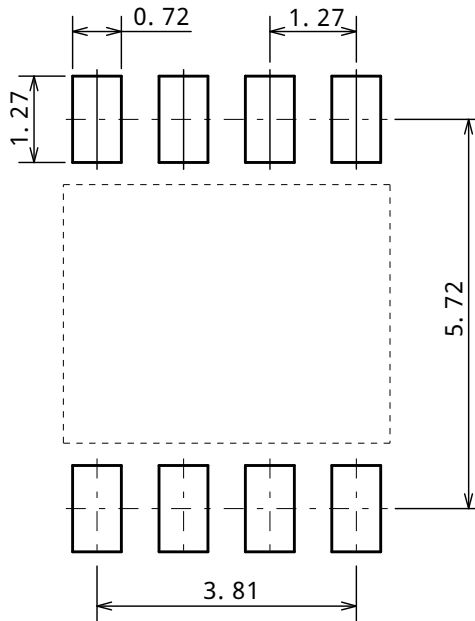

MSOP8 (TVSP8) JEDEC MO-187-DA/THIN TYPE

Unit: mm

■ PACKAGE DIMENSIONS

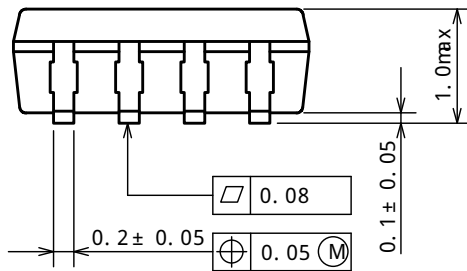
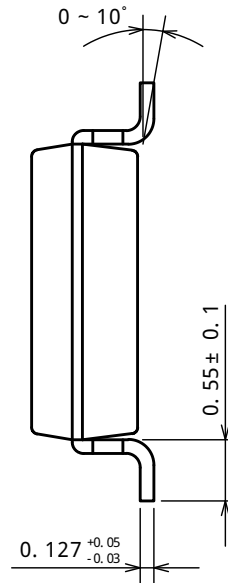
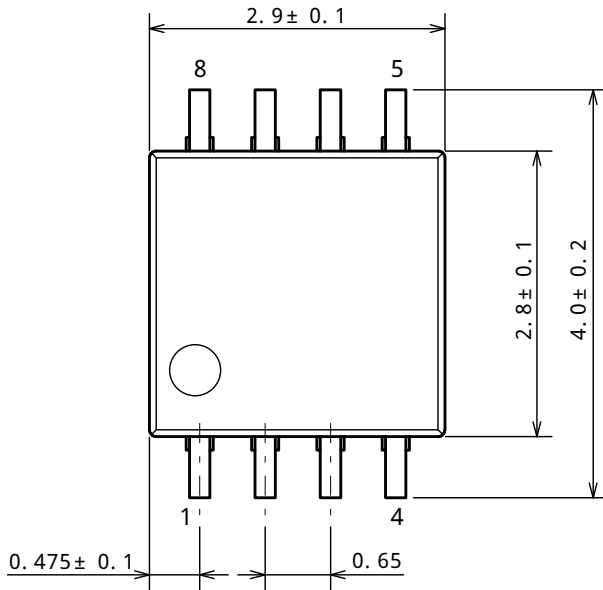

■ EXAMPLE OF SOLDER PADS DIMENSIONS

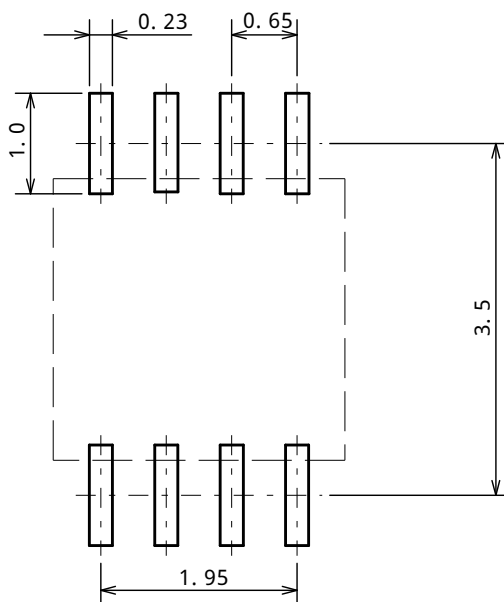

SSOP8

Unit: mm

■ PACKAGE DIMENSIONS

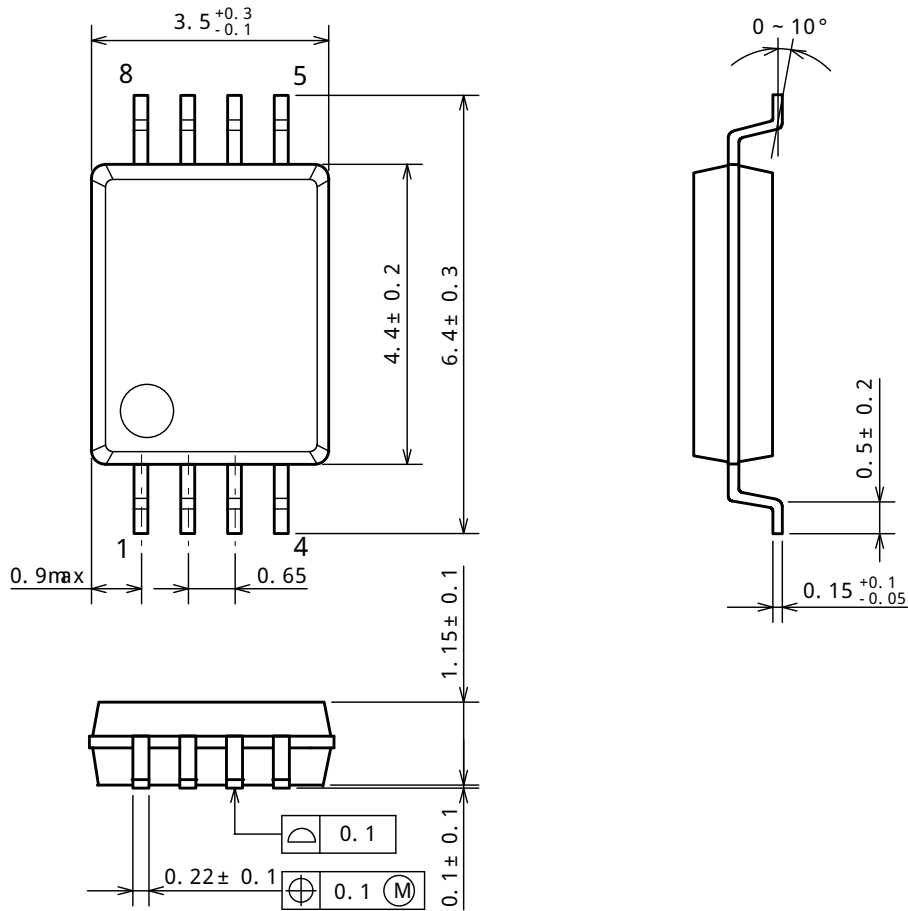

■ EXAMPLE OF SOLDER PADS DIMENSIONS

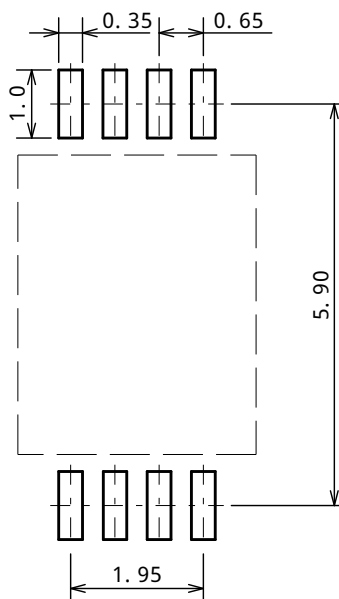

SOP8

PACKING SPEC

Unit: mm

REEL DIMENSIONS / TAPING DIMENSIONS

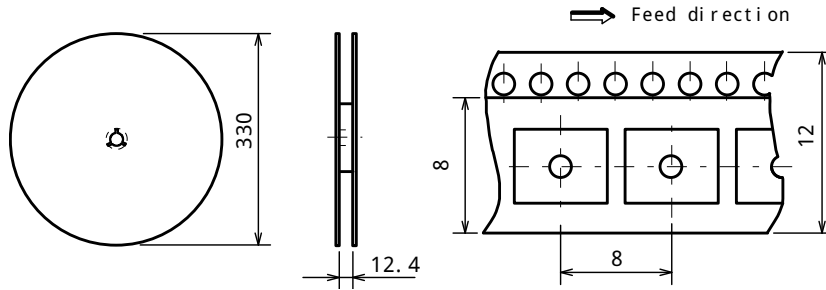

TAPING STATE

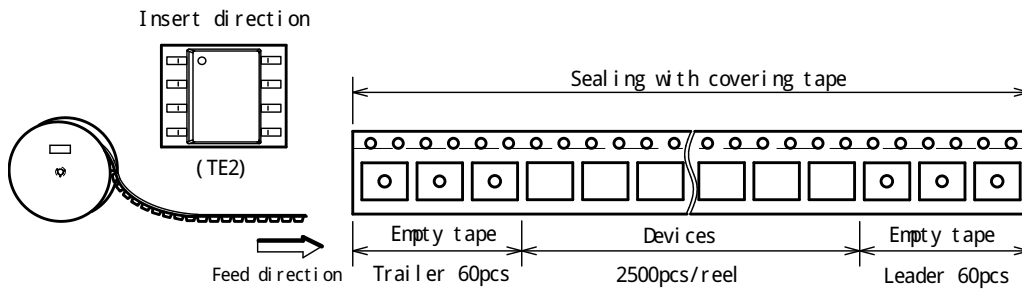

PACKING STATE

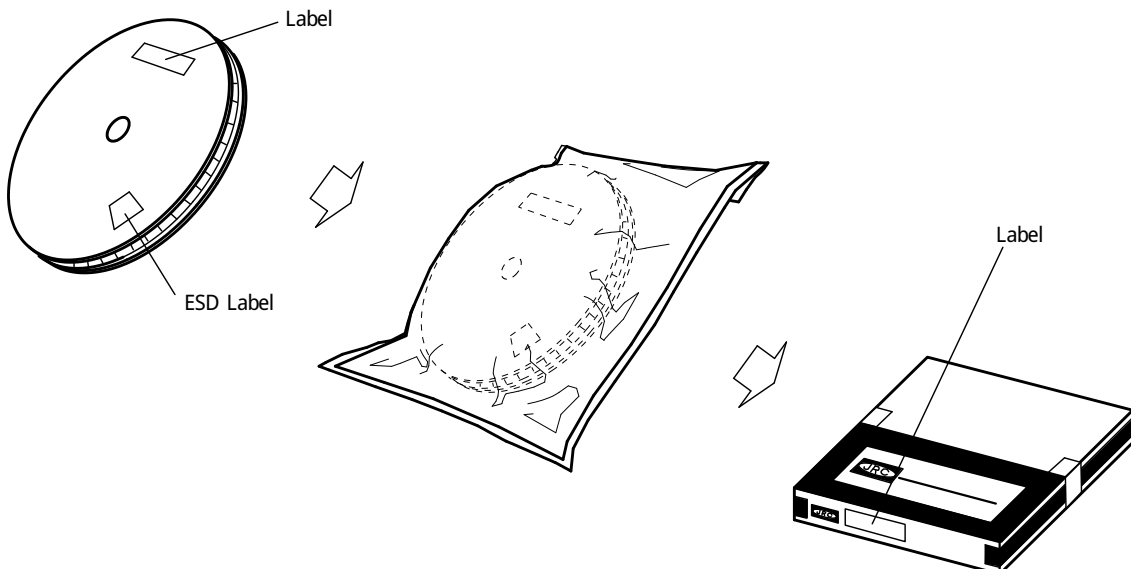

MSOP8 (TVSP8) MEET JEDEC MO-187-DATHIN TYPE

PACKING SPEC

Unit: mm

TAPING DIMENSIONS

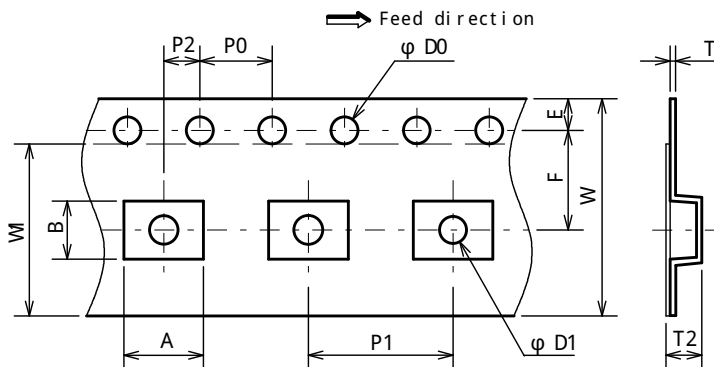

SYMBOL	DI MENSION	REMARKS
A	4.4	BOTTOM DI MENSION
B	3.2	BOTTOM DI MENSION
D0	1.5 ^{+0.1} ₀	
D1	1.5 ^{+0.1} ₀	
E	1.75± 0.1	
F	5.5± 0.05	
P0	4.0± 0.1	
P1	8.0± 0.1	
P2	2.0± 0.05	
T	0.30± 0.05	
T2	1.75 (MAX.)	
W	12.0± 0.3	
W1	9.5	THICKNESS 0.1max

REEL DIMENSIONS

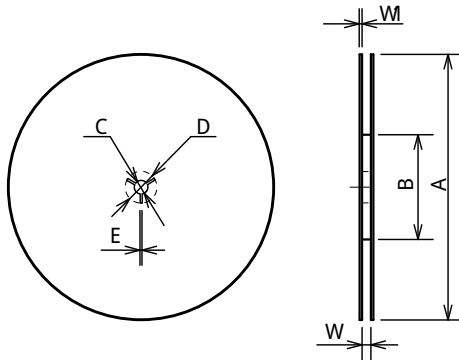

SYMBOL	DI MENSION
A	φ 254± 2
B	φ 100± 1
C	φ 13± 0.2
D	φ 21± 0.8
E	2± 0.5
W	13.5± 0.5
W1	2.0± 0.2

TAPING STATE

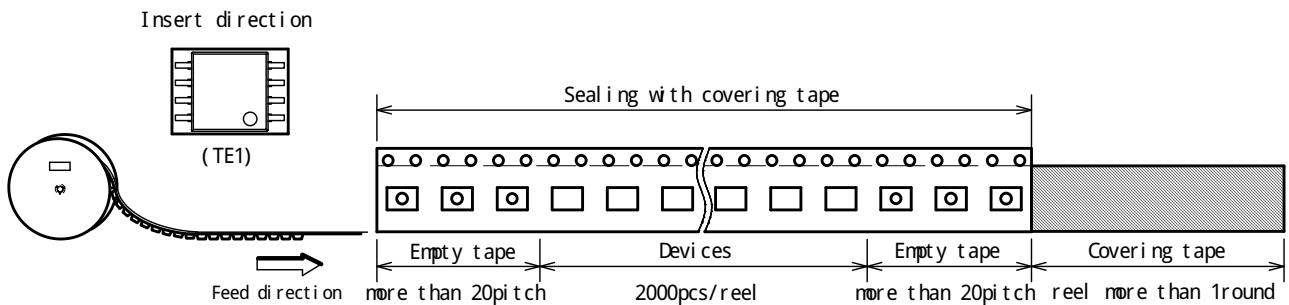

PACKING STATE

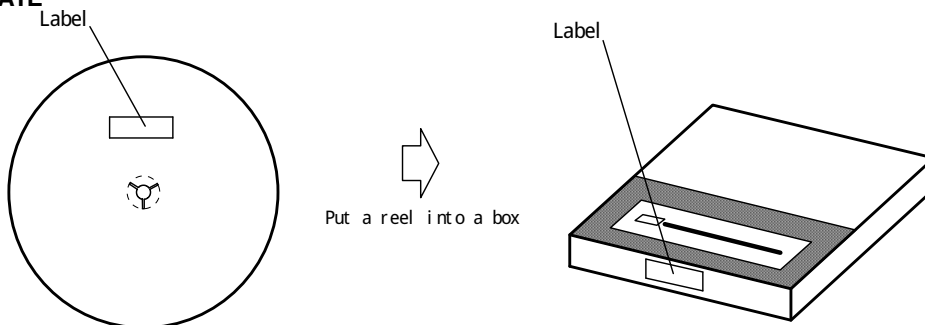

SSOP8

PACKING SPEC

Unit: mm

TAPING DIMENSIONS

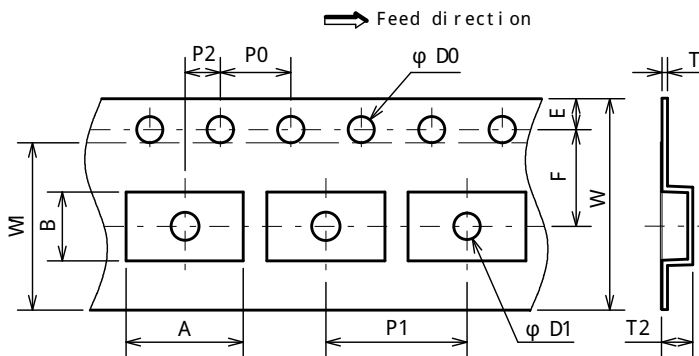

SYMBOL	DI MENSION	REMARKS
A	6.7	BOTTOM DI MENSION
B	3.9	BOTTOM DI MENSION
D0	1.55± 0.05	
D1	1.55± 0.1	
E	1.75± 0.1	
F	5.5± 0.05	
P0	4.0± 0.1	
P1	8.0± 0.1	
P2	2.0± 0.05	
T	0.3± 0.05	
T2	2.2	
W	12.0± 0.3	
W	9.5	THICKNESS 0.1max

REEL DIMENSIONS

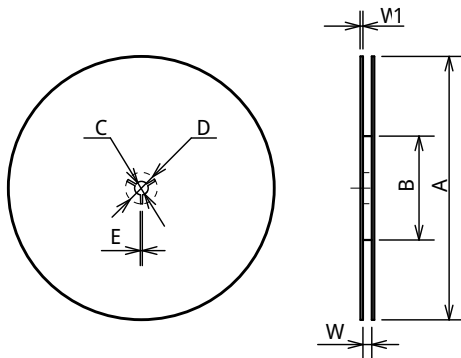

SYMBOL	DI MENSION
A	φ 254± 2
B	φ 100± 1
C	φ 13± 0.2
D	φ 21± 0.8
E	2± 0.5
W	13.5± 0.5
V1	2± 0.2

TAPING STATE

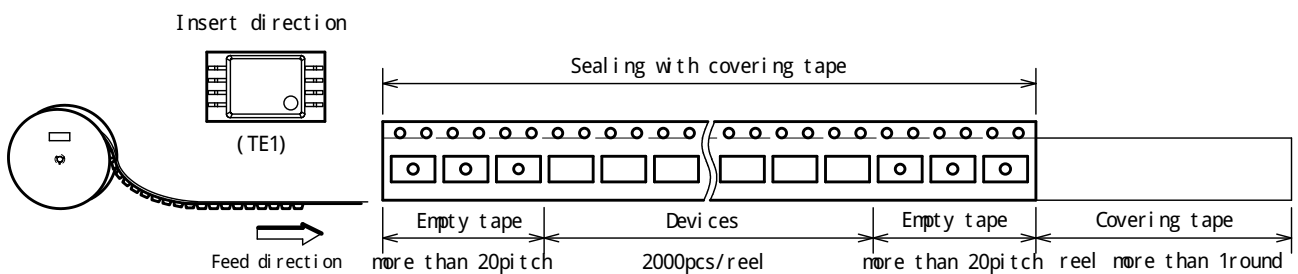

PACKING STATE

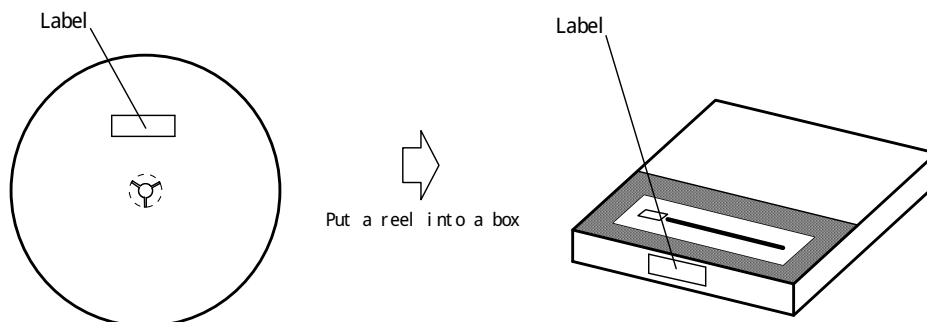

■ RECOMMENDED MOUNTING METHOD

INFRARED REFLOW SOLDERING PROFILE

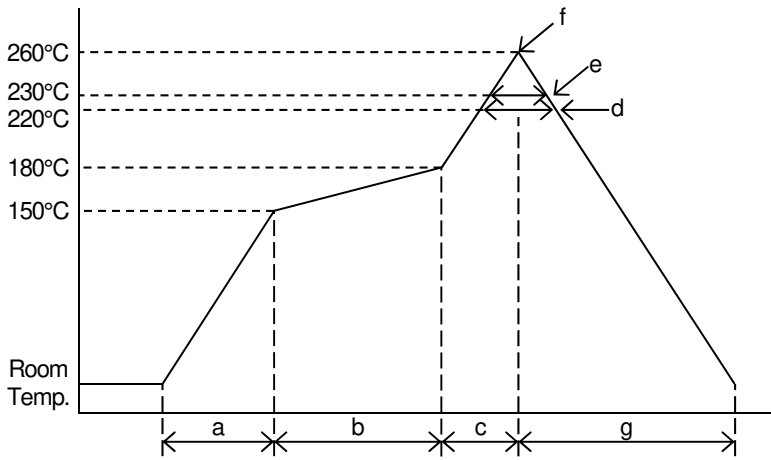

a	Temperature ramping rate	1 to 4°C/s
b	Pre-heating temperature Pre-heating time	150 to 180°C 60 to 120s
c	Temperature ramp rate	1 to 4°C/s
d	220°C or higher time	shorter than 60s
e	230°C or higher time	shorter than 40s
f	Peak temperature	lower than 260°C
g	Temperature ramping rate	1 to 6°C/s

The temperature indicates at the surface of mold package.

[CAUTION]

1. New JRC strives to produce reliable and high quality semiconductors. New JRC's semiconductors are intended for specific applications and require proper maintenance and handling. To enhance the performance and service of New JRC's semiconductors, the devices, machinery or equipment into which they are integrated should undergo preventative maintenance and inspection at regularly scheduled intervals. Failure to properly maintain equipment and machinery incorporating these products can result in catastrophic system failures
2. The specifications on this datasheet are only given for information without any guarantee as regards either mistakes or omissions. The application circuits in this datasheet are described only to show representative usages of the product and not intended for the guarantee or permission of any right including the industrial rights.
All other trademarks mentioned herein are the property of their respective companies.
3. To ensure the highest levels of reliability, New JRC products must always be properly handled.
The introduction of external contaminants (e.g. dust, oil or cosmetics) can result in failures of semiconductor products.
4. New JRC offers a variety of semiconductor products intended for particular applications. It is important that you select the proper component for your intended application. You may contact New JRC's Sale's Office if you are uncertain about the products listed in this catalog.
5. Special care is required in designing devices, machinery or equipment which demand high levels of reliability. This is particularly important when designing critical components or systems whose failure can foreseeably result in situations that could adversely affect health or safety. In designing such critical devices, equipment or machinery, careful consideration should be given to amongst other things, their safety design, fail-safe design, back-up and redundancy systems, and diffusion design.
6. The products listed in the catalog may not be appropriate for use in certain equipment where reliability is critical or where the products may be subjected to extreme conditions. You should consult our sales office before using the products in any of the following types of equipment.

Aerospace Equipment
Equipment Used in the Deep Sea
Power Generator Control Equipment (Nuclear, steam, hydraulic, etc.)
Life Maintenance Medical Equipment
Fire Alarms / Intruder Detectors
Vehicle Control Equipment (Airplane, railroad, ship, etc.)
Various Safety Devices

7. New JRC's products have been designed and tested to function within controlled environmental conditions. Do not use products under conditions that deviate from methods or applications specified in this catalog. Failure to employ New JRC products in the proper applications can lead to deterioration, destruction or failure of the products. New JRC shall not be responsible for any bodily injury, fires or accident, property damage or any consequential damages resulting from misuse or misapplication of its products. Products are sold without warranty of any kind, either express or implied, including but not limited to any implied warranty of merchantability or fitness for a particular purpose.
8. Warning for handling Gallium and Arsenic (GaAs) products (Applying to GaAs MMIC, Photo Reflector). These products use Gallium (Ga) and Arsenic (As) which are specified as poisonous chemicals by law. For the prevention of a hazard, do not burn, destroy, or process chemically to make them as gas or power. When the product is disposed, please follow the related regulation and do not mix this with general industrial waste or household waste.
9. The product specifications and descriptions listed in this catalog are subject to change at any time, without notice.

