

BACKPLANE HOLE PATTERN (CONNECTOR SIDE)

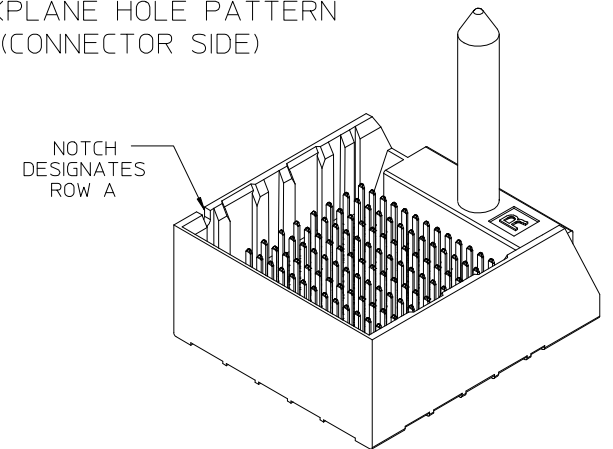

ENDWALL VERSION SHOWN

- NOTES:
1. MATERIALS: HOUSING - LIQUID CRYSTAL POLYMER (LCP)
GLASS-FILLED, UL94V-0
TERMINALS - HIGH PERFORMANCE COPPER ALLOY
 2. FINISH: 30µ MIN GOLD IN CONTACT AREA.
SELECTIVE MATTE TIN (LEAD-FREE) ON PCB TAILS.
NICKEL OVERALL.
 3. REFER TO MOLEX PRODUCT SPECIFICATION PS-76060-999
FOR PERFORMANCE SPECIFICATIONS AND ADDITIONAL PCB INFORMATION.
 4. THIS PART CONFORMS TO CLASS B REQUIREMENTS OF
COSMETIC SPEC PS-45499-002.
 5. PRODUCT IS PACKAGED PER PK-70873-765.
 6. SEE SHEETS 2 THRU 4 FOR PART NUMBERS AND ORTHOGONAL PIN MAPPING.
 7. REFER TO MOLEX SALES DRAWING SD-76990-002 FOR THE MATING RECEPTACLES.
 8. REFER TO MOLEX ROUTING GUIDE AS-76850-990 FOR ADDITIONAL PCB LAYOUT
AND ROUTING RECOMMENDATIONS.
 9. THE KEEP-OUT ZONE FOR THE PART LENGTH INCLUDES AN ADDITIONAL 1.0mm
TO ACCOMMODATE FOR SPACE REQUIRED BY THE DAUGHTERCARD ASSEMBLY.
 10. CONNECTORS ARE SUPPLIED WITH A 2-56 UNC-2A CUSTOM SCREW.
 - 11.*THESE DIMENSIONS REPRESENT THE AREA NEEDED TO ACCOMMODATE CONNECTOR
INSERTION AND REPAIR ON THE PC BOARD. THIS DOES NOT REPRESENT
THE ACTUAL PERIMETER OF THE CONNECTOR.*

INITIAL RELEASE EC NO: UCP2014-2268 DRWNR:ZV101 2013/03/05 CHKD:TELO 2013/11/22 APPR:TELO 2013/12/04	QUALITY SYMBOLS ▽=0 ▽=0 ▽=0	GENERAL TOLERANCES (UNLESS SPECIFIED)		DIMENSION STYLE MM ONLY		SCALE 4:1	DESIGN UNITS METRIC	THIRD ANGLE PROJECTION		
		4 PLACES ± --- ± ---	mm	INCH	DRAWN BY ARIZV101	DATE 2013/03/05	IMPACT 5 PAIR HEADER ORTHOGONAL ASSEMBLY GUIDE RIGHT SALES DWG molex DOCUMENT NO. SD-171884-0003 SHEET NO. 1 OF 4			
		3 PLACES ± --- ± ---			CHECKED BY JMENDOZA	DATE 2013/11/22				
		2 PLACES ± 0.13 ± ---			APPROVED BY TELO	DATE 2013/12/04				
		1 PLACE ± 0.25 ± ---								
0 PLACE ± ±										
ANGULAR ±1/2°		DRAFT WHERE APPLICABLE MUST REMAIN WITHIN DIMENSIONS		MATERIAL NO. SEE CHART						
REV: A		SIZE: C		THIS DRAWING CONTAINS INFORMATION THAT IS PROPRIETARY TO MOLEX INCORPORATED AND SHOULD NOT BE USED WITHOUT WRITTEN PERMISSION						

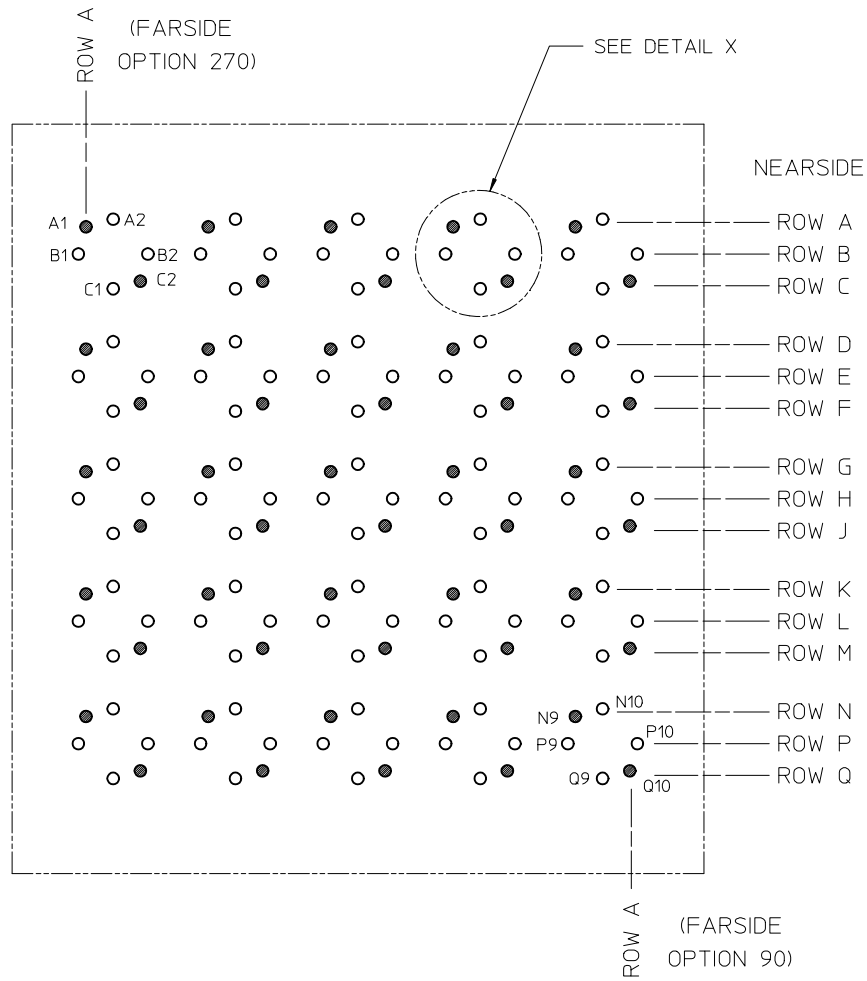

MATERIAL NUMBER	# OF COLUMNS	# OF DIFF PAIR	MODULE TYPE	DIM A	DIM B	DIM C
171884-*80*	8	40	NO ENDWALL	22.9	14.05	14.45
171884-*80*	8	40	WITH ENDWALL	24.3	14.05	14.45
171884-*10*	10	50	NO ENDWALL	27.0	18.10	18.50
171884-*10*	10	50	WITH ENDWALL	28.4	18.10	18.50
171884-*20*	12	60	NO ENDWALL	31.0	22.15	22.55
171884-*20*	12	60	WITH ENDWALL	32.4	22.15	22.55

MIDPLANE PCB LAYOUT
SCALE 8:1

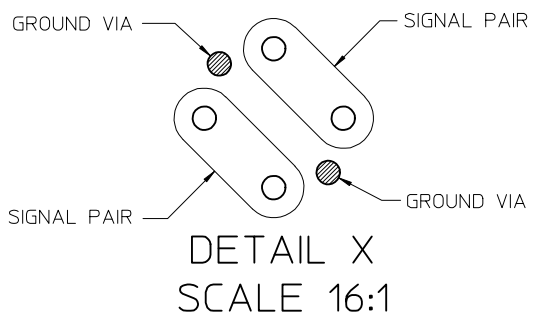

171884-*x*0*

MODULE & TAIL PLATING TYPE
 5 = GUIDE RIGHT NO ENDWALL, TIN
 9 = GUIDE RIGHT ENDWALL, TIN

PIN LENGTH (P)
 4 = 4.90 (0.46 PTH)
 5 = 5.50 (0.46 PTH)
 7 = 4.90 (0.39 PTH)
 8 = 5.50 (0.39 PTH)

OF COLUMNS
 8 = 8 COLUMNS
 1 = 10 COLUMNS
 2 = 12 COLUMNS

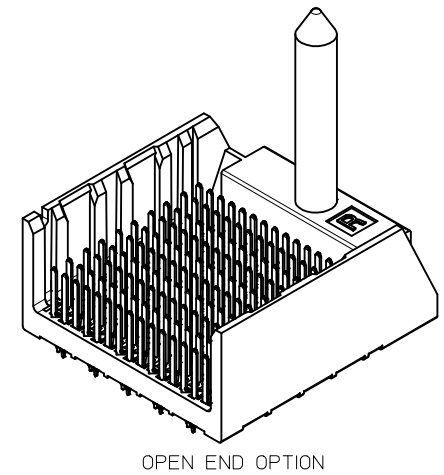

SEE SHEET 1 EC NO: UCP2014-2268 DRW: ARIZV101 2013/03/05 CHKD: TELO 2013/11/22 APPR: TELO 2013/12/04	QUALITY SYMBOLS ▽=0 ▽=0 ▽=0	GENERAL TOLERANCES (UNLESS SPECIFIED)		DIMENSION STYLE MM ONLY		SCALE 3:1	DESIGN UNITS METRIC	THIRD ANGLE PROJECTION		
		4 PLACES ± --- ± ---	mm	INCH	DRAWN BY ARIZV101	DATE 2013/03/05	TITLE IMPACT 5 PAIR HEADER ORTHOGONAL ASSEMBLY GUIDE RIGHT SALES DWG molex DOCUMENT NO. SD-171884-0003 SHEET NO. 2 OF 4			
		3 PLACES ± --- ± ---			CHECKED BY JMENDOZA	DATE 2013/11/22				
		2 PLACES ± 0.13 ± ---			APPROVED BY	DATE 2013/12/04				
1 PLACE ± 0.25 ± ---			TELO							
0 PLACE ± ±			MATERIAL NO.		DOCUMENT NO.					
DRAFT WHERE APPLICABLE MUST REMAIN WITHIN DIMENSIONS				SEE CHART						
THIS DRAWING CONTAINS INFORMATION THAT IS PROPRIETARY TO MOLEX INCORPORATED AND SHOULD NOT BE USED WITHOUT WRITTEN PERMISSION										

ORTHO PIN MAPPING									
OPTION 270 (NEARSIDE - FAR SIDE)									
A1-A1	A2-B1	A3-D1	A4-E1	A5-G1	A6-H1	A7-K1	A8-L1	A9-N1	A10-P1
B1-A2	B2-C1	B3-D2	B4-F1	B5-G2	B6-J1	B7-K2	B8-M1	B9-N2	B10-O1
C1-B2	C2-C2	C3-E2	C4-F2	C5-H2	C6-J2	C7-L2	C8-M2	C9-P2	C10-Q2
D1-A3	D2-B3	D3-D3	D4-E3	D5-G3	D6-H3	D7-K3	D8-L3	D9-N3	D10-P3
E1-A4	E2-C3	E3-D4	E4-F3	E5-G4	E6-J3	E7-K4	E8-M3	E9-N4	E10-Q3
F1-B4	F2-C4	F3-E4	F4-F4	F5-H4	F6-J4	F7-L4	F8-M4	F9-P4	F10-Q4
G1-A5	G2-B5	G3-D5	G4-E5	G5-G5	G6-H5	G7-K5	G8-L5	G9-N5	G10-P5
H1-A6	H2-C5	H3-D6	H4-F5	H5-G6	H6-J5	H7-K6	H8-M5	H9-N6	H10-Q5
J1-B6	J2-C6	J3-E6	J4-F6	J5-H6	J6-J6	J7-L6	J8-M6	J9-P6	J10-Q6
K1-A7	K2-B7	K3-D7	K4-E7	K5-G7	K6-H7	K7-K7	K8-L7	K9-N7	K10-P7
L1-A8	L2-C7	L3-D8	L4-F7	L5-G8	L6-J7	L7-K8	L8-M7	L9-N8	L10-Q7
M1-B8	M2-C8	M3-E8	M4-F8	M5-H8	M6-J8	M7-L8	M8-M8	M9-P8	M10-Q8
N1-A9	N2-B9	N3-D9	N4-E9	N5-G9	N6-H9	N7-K9	N8-L9	N9-N9	N10-P9
P1-A10	P2-C9	P3-D10	P4-F9	P5-G10	P6-J9	P7-K10	P8-M9	P9-N10	P10-Q9
Q1-B10	Q2-C10	Q3-E10	Q4-F10	Q5-H10	Q6-J10	Q7-L10	Q8-M10	Q9-P10	Q10-Q10

NOTE: PINOUTS SHOWN IN BALLOONS ARE GROUNDS.
 PINOUTS SHOWN ARE FOR SQUARE (10 COLUMN) PATTERN ONLY.

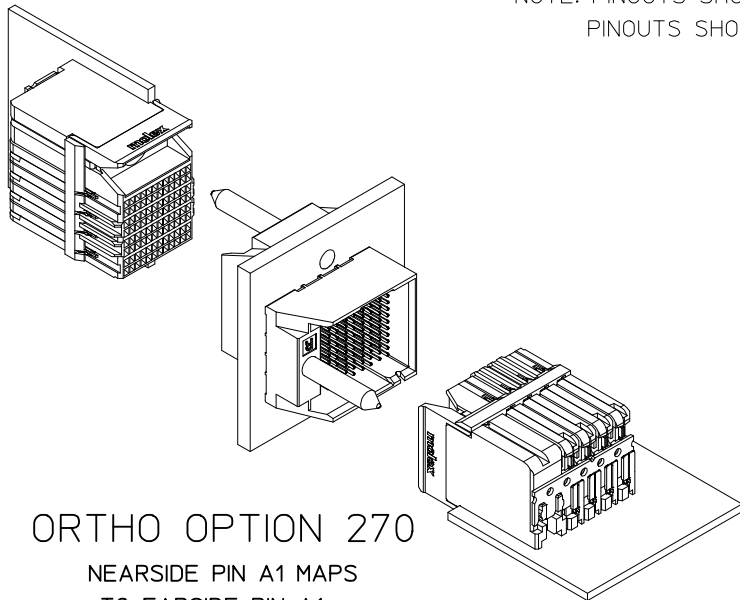

ORTHO OPTION 270
 NEARSIDE PIN A1 MAPS
 TO FAR SIDE PIN A1

SEE SHEET 1 EC NO: UCP2014-2268 DRWNR: ARIZV101 CHKD: TELO APPR: TELO	2013/03/05 2013/11/22 2013/12/04	QUALITY SYMBOLS ▽=0 ▽=0 ▽=0	GENERAL TOLERANCES (UNLESS SPECIFIED)		DIMENSION STYLE MM ONLY		SCALE 8:1	DESIGN UNITS METRIC	THIRD ANGLE PROJECTION	
			4 PLACES ± ---	± ---	mm	INCH	DRAWN BY ARIZV101	DATE 2013/03/05	TITLE IMPACT 5 PAIR HEADER ORTHOGONAL ASSEMBLY GUIDE RIGHT SALES DWG molex DOCUMENT NO. SD-171884-0003	SHEET NO. 3 OF 4
			3 PLACES ± ---	± ---			CHECKED BY JMENDOZA	DATE 2013/11/22		
			2 PLACES ± 0.13	± ---			APPROVED BY TELO	DATE 2013/12/04		
1 PLACE ± 0.25	± ---									
				0 PLACE ±	±					
				ANGULAR ±1/2°		MATERIAL NO.		DOCUMENT NO.		
				DRAFT WHERE APPLICABLE MUST REMAIN WITHIN DIMENSIONS		SEE CHART		SD-171884-0003		
						SIZE C		THIS DRAWING CONTAINS INFORMATION THAT IS PROPRIETARY TO MOLEX INCORPORATED AND SHOULD NOT BE USED WITHOUT WRITTEN PERMISSION		

ORTHO PIN MAPPING

OPTION 90 (NEARSIDE - FAR SIDE)

A1-Q10	A2-P10	A3-M10	A4-L10	A5-J10	A6-H10	A7-F10	A8-E10	A9-C10	A10-B10
B1-Q9	B2-N10	B3-M9	B4-K10	B5-J9	B6-G10	B7-F9	B8-D10	B9-C9	B10-A10
C1-P9	C2-N9	C3-L9	C4-K9	C5-H9	C6-G9	C7-E9	C8-D9	C9-B9	C10-A9
D1-Q8	D2-P8	D3-M8	D4-L8	D5-J8	D6-H8	D7-F8	D8-E8	D9-C8	D10-B8
E1-Q7	E2-N8	E3-M7	E4-K8	E5-J7	E6-G8	E7-F7	E8-D8	E9-C7	E10-A8
F1-P7	F2-N7	F3-L7	F4-K7	F5-H7	F6-G7	F7-E7	F8-D7	F9-B7	F10-A7
G1-Q6	G2-P6	G3-M6	G4-L6	G5-J6	G6-H6	G7-F6	G8-E6	G9-C6	G10-B6
H1-Q5	H2-N6	H3-M5	H4-K6	H5-J5	H6-G6	H7-F5	H8-D6	H9-C5	H10-A6
J1-P5	J2-N5	J3-L5	J4-K5	J5-H5	J6-G5	J7-E5	J8-D5	J9-B5	J10-A5
K1-Q4	K2-P4	K3-M4	K4-L4	K5-J4	K6-H4	K7-F4	K8-E4	K9-C4	K10-B4
L1-Q3	L2-N4	L3-M3	L4-K4	L5-J3	L6-G4	L7-F3	L8-D4	L9-C3	L10-A4
M1-P3	M2-N3	M3-L3	M4-K3	M5-H3	M6-G3	M7-E3	M8-D3	M9-B3	M10-A3
N1-Q2	N2-P2	N3-M2	N4-L2	N5-J2	N6-H2	N7-F2	N8-E2	N9-C2	N10-B2
P1-Q1	P2-N2	P3-M1	P4-K2	P5-J1	P6-G2	P7-F1	P8-D2	P9-C1	P10-A2
Q1-P1	Q2-N1	Q3-L1	Q4-K1	Q5-H1	Q6-G1	Q7-E1	Q8-D1	Q9-B1	Q10-A1

NOTE: PINOUTS SHOWN IN BALLOONS ARE GROUNDS.
PINOUTS SHOWN ARE FOR SQUARE (10 COLUMN) PATTERNS ONLY.

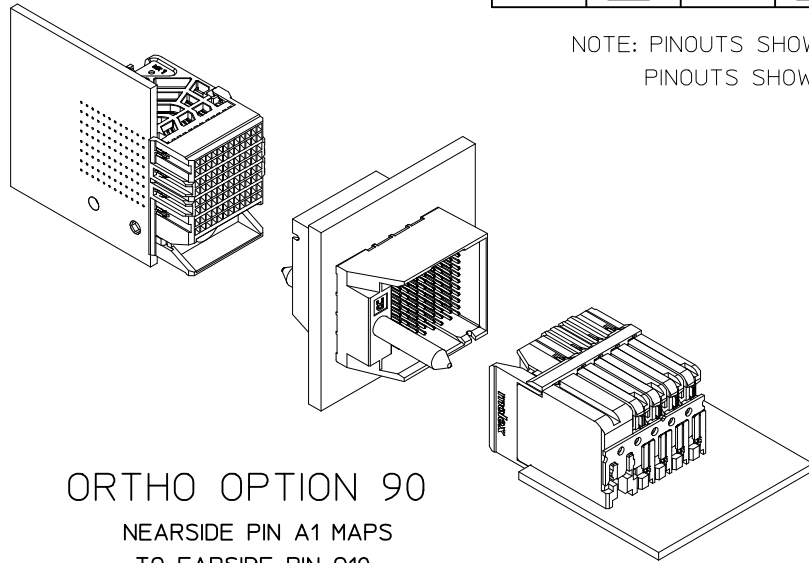

ORTHO OPTION 90
NEARSIDE PIN A1 MAPS
TO FAR SIDE PIN Q10
(FOR SQUARE PATTERN)

SEE SHEET 1 EC NO: UCP2014-2268 DRWN: ARIZV101 2013/03/05 CHKD: TELO 2013/11/22 APPR: TELO 2013/12/04	QUALITY SYMBOLS ▽=0 ▽=0 ▽=0	GENERAL TOLERANCES (UNLESS SPECIFIED)		DIMENSION STYLE MM ONLY		SCALE 4:1	DESIGN UNITS METRIC	THIRD ANGLE PROJECTION		
		4 PLACES ± ---	± ---	mm	INCH	DRAWN BY ARIZV101	DATE 2013/03/05	TITLE IMPACT 5 PAIR HEADER ORTHOGONAL ASSEMBLY GUIDE RIGHT SALES DWG molex MATERIAL NO. SD-171884-0003 DOCUMENT NO. SD-171884-0003 SHEET NO. 4 OF 4		
		3 PLACES ± ---	± ---			CHECKED BY JMENDOZA	DATE 2013/11/22			
		2 PLACES ± 0.13	± ---			APPROVED BY TELO	DATE 2013/12/04			
1 PLACE ± 0.25	± ---									
		0 PLACE ±	±							
		ANGULAR ±1/2°		SEE CHART						
		DRAFT WHERE APPLICABLE MUST REMAIN WITHIN DIMENSIONS		SIZE C		THIS DRAWING CONTAINS INFORMATION THAT IS PROPRIETARY TO MOLEX INCORPORATED AND SHOULD NOT BE USED WITHOUT WRITTEN PERMISSION				

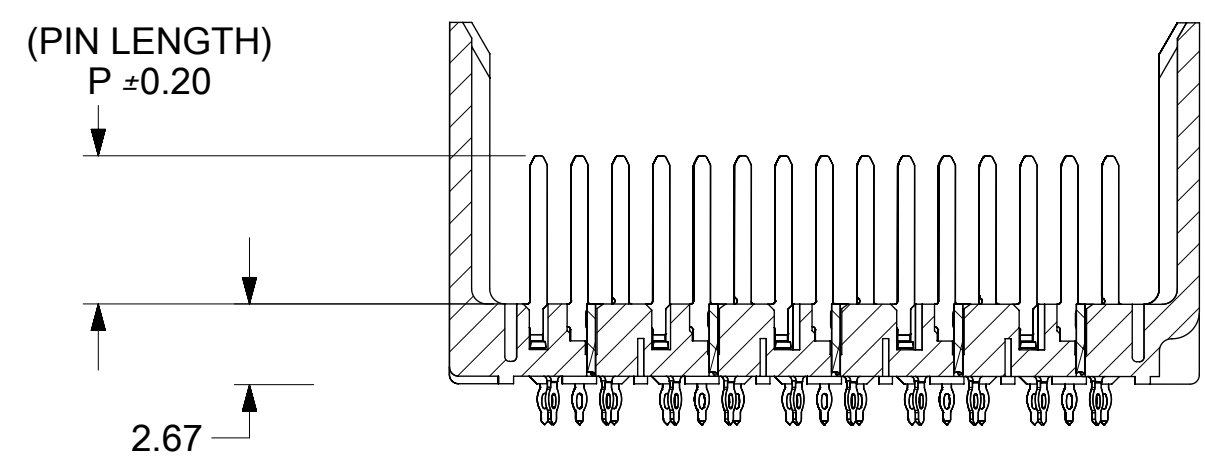
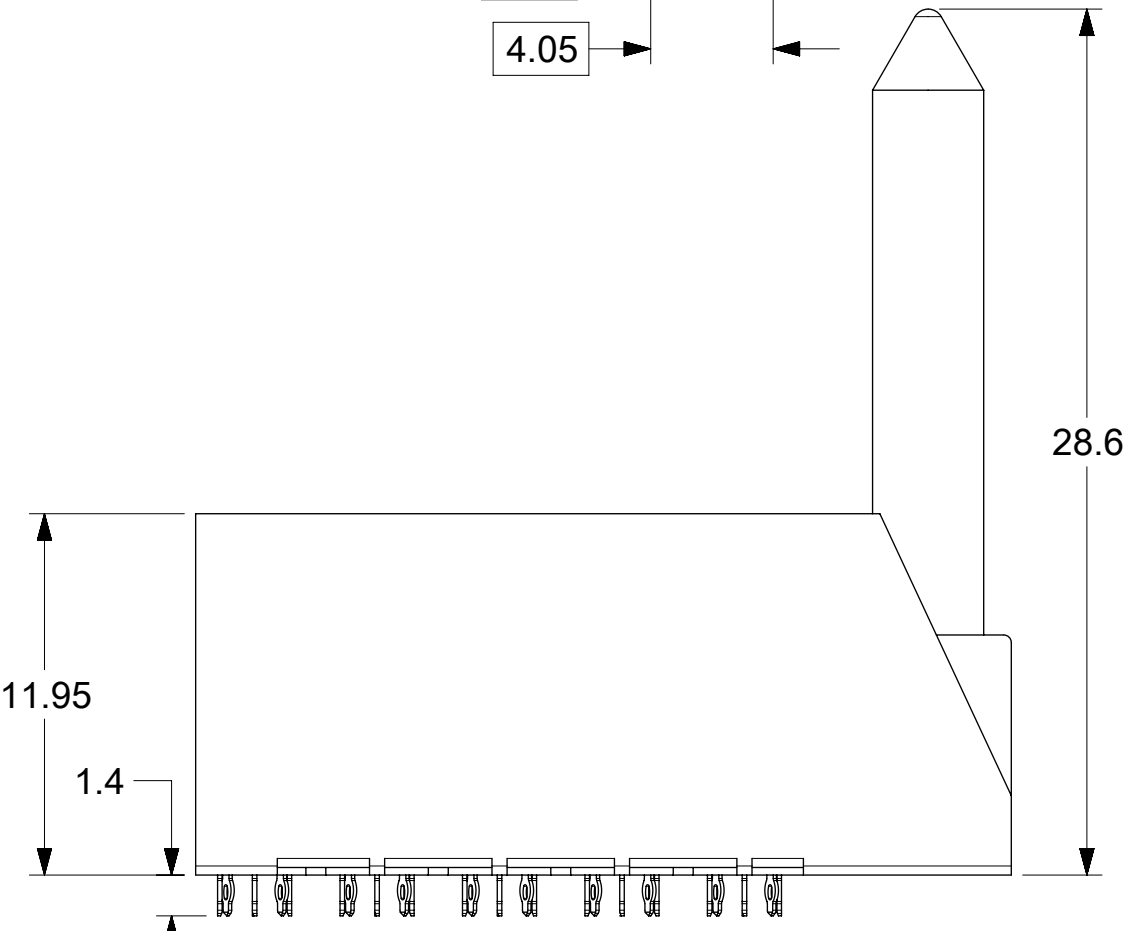
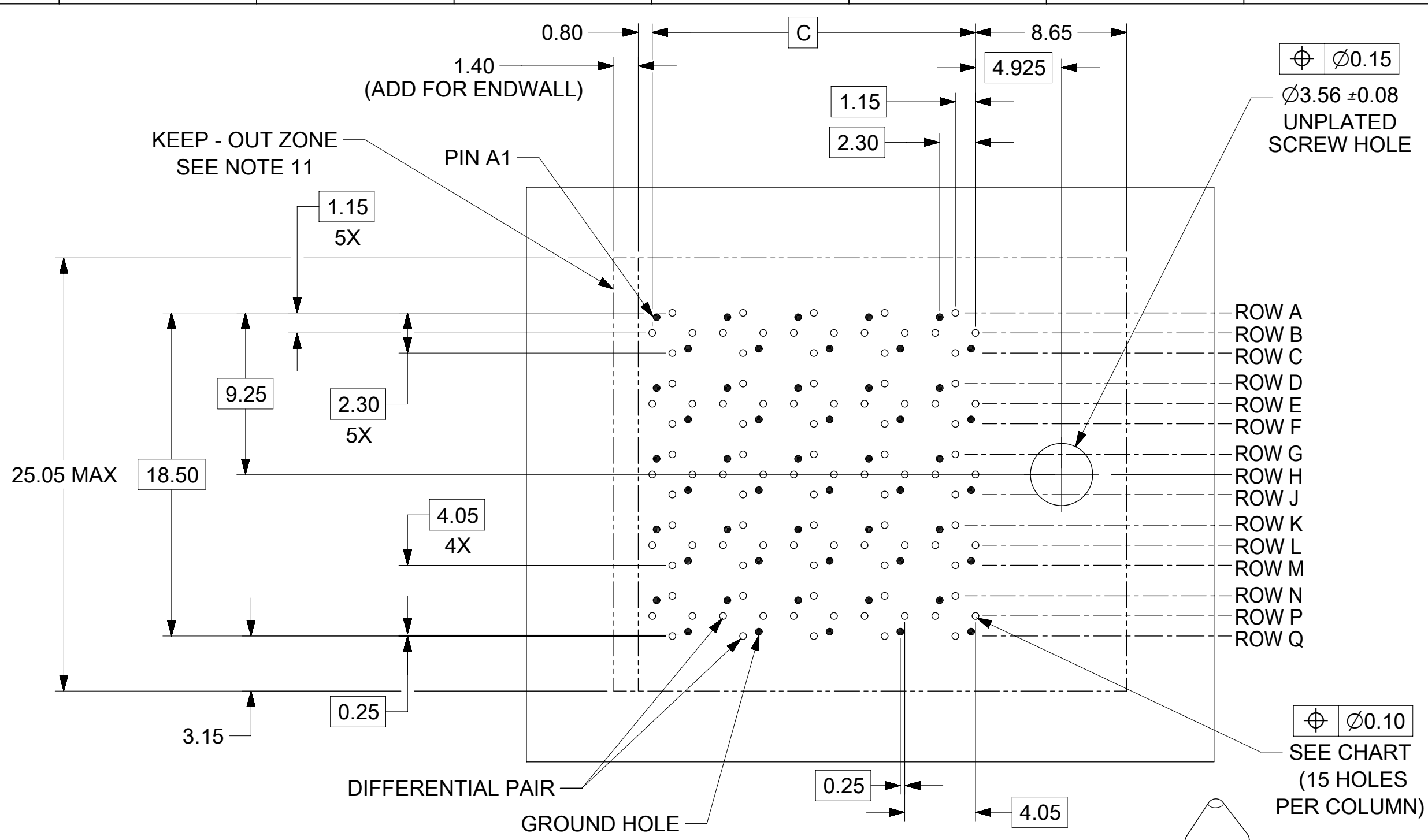
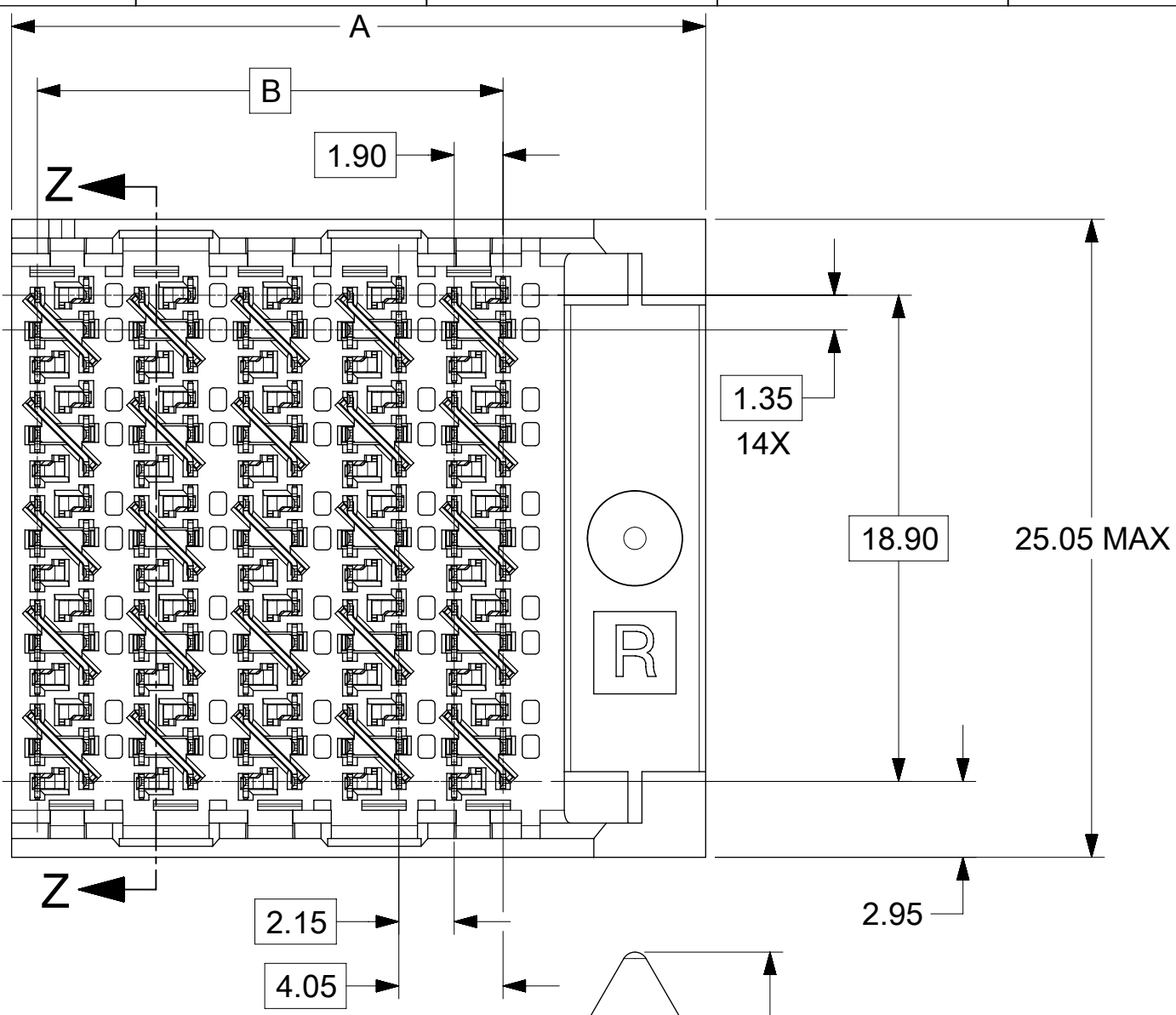

**BACKPLANE HOLE PATTERN
(CONNECTOR SIDE)**

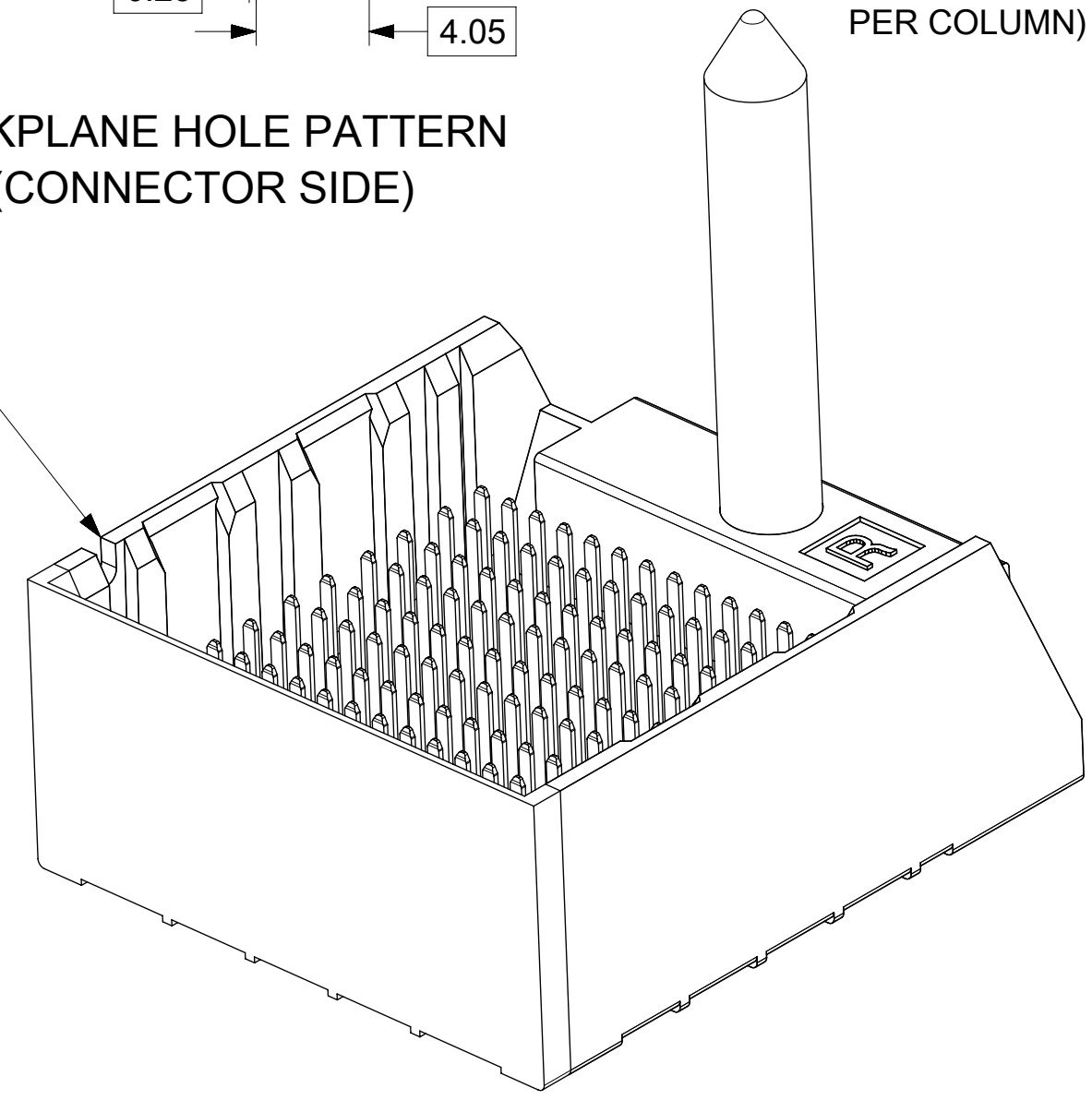

- NOTES:**
1. MATERIALS: HOUSING - LIQUID CRYSTAL POLYMER (LCP) GLASS-FILLED, UL94V-0
TERMINALS - HIGH PERFORMANCE COPPER ALLOY
 2. FINISH: 30µ MIN GOLD IN CONTACT AREA.
SELECTIVE TIN OR TIN-LEAD ON PCB TAILS.
NICKEL OVERALL.
 3. REFER TO MOLEX PRODUCT SPECIFICATION PS-76060-999 FOR PERFORMANCE SPECIFICATIONS AND ADDITIONAL PCB INFORMATION.
 4. THIS PART CONFORMS TO CLASS B REQUIREMENTS OF COSMETIC SPEC PS-45499-002.
 5. PRODUCT IS PACKAGED PER PK-70873-765.
 6. SEE SHEETS 2 THRU 4 FOR PART NUMBERS AND ORTHOGONAL PIN MAPPING.
 7. REFER TO MOLEX SALES DRAWING SD-76990-002 FOR THE MATING RECEPTACLES.
 8. REFER TO MOLEX ROUTING GUIDE AS-76850-990 FOR ADDITIONAL PCB LAYOUT AND ROUTING RECOMMENDATIONS.
 9. THE KEEP-OUT ZONE FOR THE PART LENGTH INCLUDES AN ADDITIONAL 1.0mm TO ACCOMMODATE FOR SPACE REQUIRED BY THE DAUGHTERCARD ASSEMBLY.
 10. CONNECTORS ARE SUPPLIED WITH A 2-56 UNC-2A SCREW.
 11. "THESE DIMENSIONS REPRESENT THE AREA NEEDED TO ACCOMMODATE CONNECTOR INSERTION AND REPAIR ON THE PC BOARD. THIS DOES NOT REPRESENT THE ACTUAL PERIMETER OF THE CONNECTOR."

SYMBOLS		THIS DRAWING CONTAINS INFORMATION THAT IS PROPRIETARY TO MOLEX ELECTRONIC TECHNOLOGIES, LLC AND SHOULD NOT BE USED WITHOUT WRITTEN PERMISSION	
▽ = 0	mm	SCALE	4:1
▽ = 0	GENERAL TOLERANCES (UNLESS SPECIFIED)		
▽ = 0	ANGULAR TOL	±	0.5°
▽ = 0	4 PLACES	±	
▽ = 0	3 PLACES	±	
▽ = 0	2 PLACES	±	0.13
▽ = 0	1 PLACE	±	0.25
▽ = 0	0 PLACES	±	
▽ = 0	DRAFT WHERE APPLICABLE MUST REMAIN WITHIN DIMENSIONS		
CURRENT REV DESC: MIGRATED TO NX		EC NO: 609931	
		DRWN: JKUMARSARAFS 2018/10/18	
		CHK'D: ABN 2019/01/04	
		APPR: CWANG25 2019/01/11	
INITIAL REVISION:		4/28/09	
DRWN: JLAURX		2010/01/14	
APPR: JBINGHAM			
THIRD ANGLE PROJECTION		DRAWING	SERIES
C-SIZE		76985	
DOCUMENT NUMBER		DOC TYPE	DOC PART
SD-76985-003		PSD	001
MATERIAL NUMBER		CUSTOMER	SHEET NUMBER
SEE CHART		GENERAL MARKET	1 OF 4

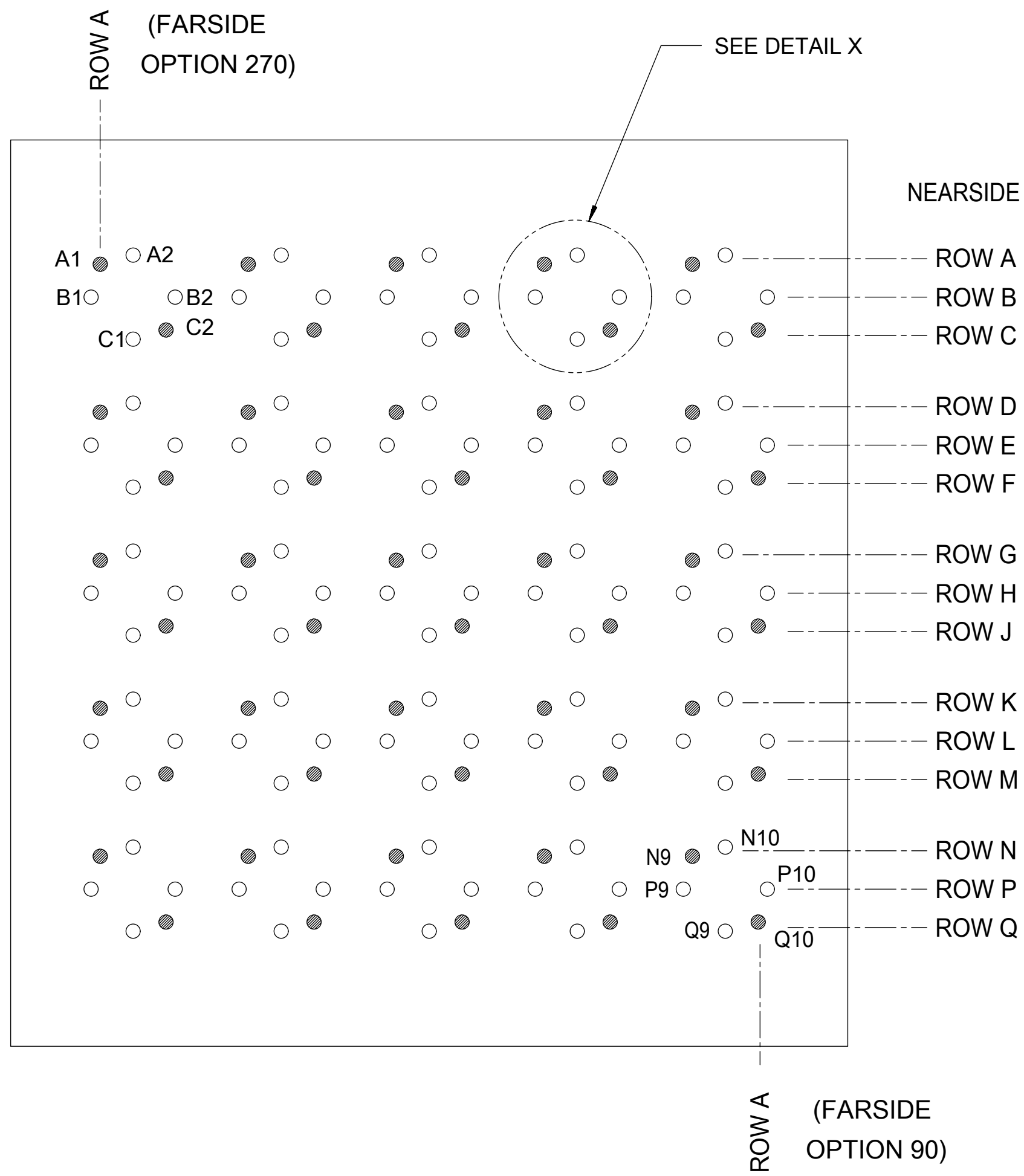

MIDPLANE PCB LAYOUT
SCALE 8:1

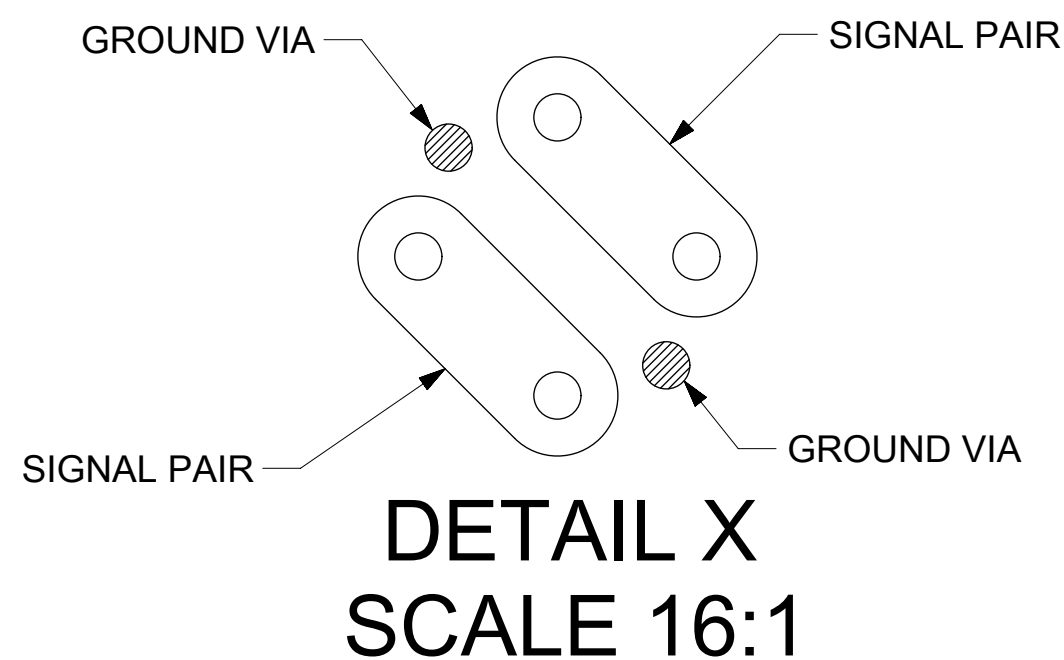

MATERIAL NUMBER	# OF COLUMNS	# OF DIFF PAIR	MODULE TYPE	DIM A	DIM B	DIM C
76985-*80*	8	40	NO ENDWALL	22.9	14.05	14.45
76985-*80*	8	40	WITH ENDWALL	24.3	14.05	14.45
76985-*10*	10	50	NO ENDWALL	27.0	18.10	18.50
76985-*10*	10	50	WITH ENDWALL	28.4	18.10	18.50
76985-*20*	12	60	NO ENDWALL	31.0	22.15	22.55
76985-*20*	12	60	WITH ENDWALL	32.4	22.15	22.55

76985- * * 0 *

MODULE & TAIL PLATING TYPE

- 4 = GUIDE RIGHT NO ENDWALL, TIN/LEAD
- 5 = GUIDE RIGHT NO ENDWALL, TIN
- 8 = GUIDE RIGHT ENDWALL, TIN/LEAD
- 9 = GUIDE RIGHT ENDWALL, TIN

PIN LENGTH (P)

- 4 = 4.90 (0.46 PTH)
- 5 = 5.50 (0.46 PTH)
- 7 = 4.90 (0.39 PTH)
- 8 = 5.50 (0.39 PTH)

OF COLUMNS

- 8 = 8 COLUMNS
- 1 = 10 COLUMNS
- 2 = 12 COLUMNS

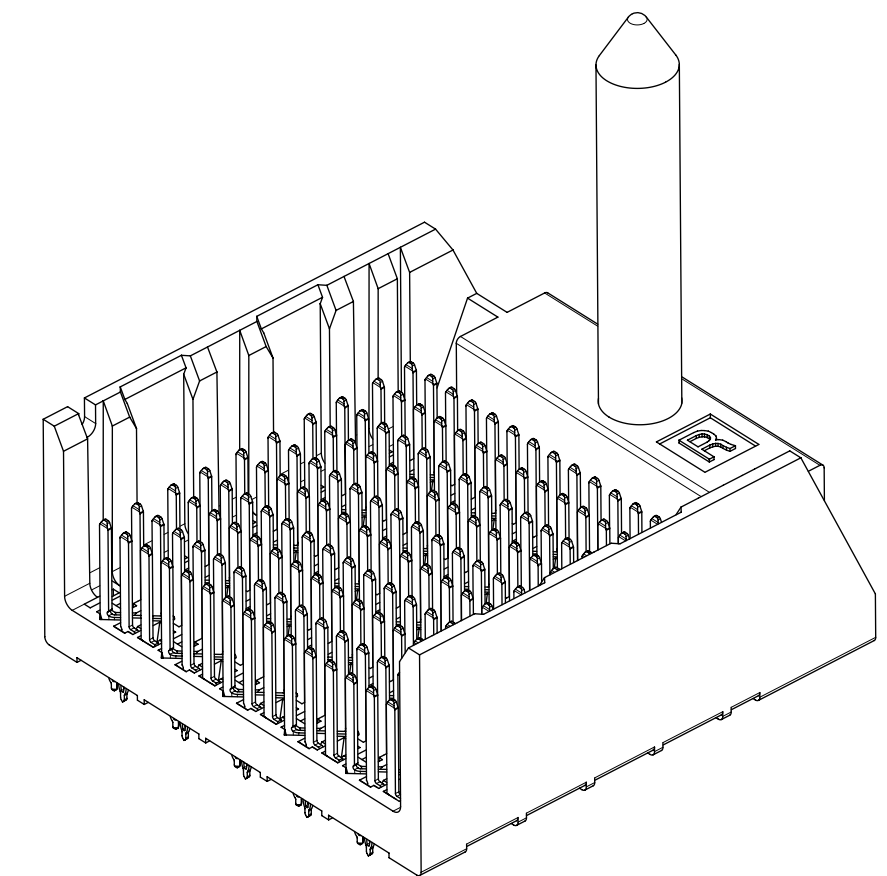

OPEN END OPTION

THIS DRAWING CONTAINS INFORMATION THAT IS PROPRIETARY TO MOLEX ELECTRONIC TECHNOLOGIES, LLC AND SHOULD NOT BE USED WITHOUT WRITTEN PERMISSION											
SYMBOLS		DIMENSION UNITS		SCALE		CURRENT REV DESC: MIGRATED TO NX					
▽ = 0 ▽ = 0 ▽ = 0 ▽ = 0 ▽ = 0 ▽ = 0 ▽ = 0 ▽ = 0 ▽ = 0 ▽ = 0		mm		3:1		GENERAL TOLERANCES (UNLESS SPECIFIED)					
						ANGULAR TOL ± 0.5°				EC NO: 609931 DRWN: JKUMARSARAFS 2018/10/18 CHK'D: ABN 2019/01/04 APPR: CWANG25 2019/01/11	
						4 PLACES ±				PRODUCT CUSTOMER DRAWING	
						3 PLACES ±				DOCUMENT NUMBER	
						2 PLACES ± 0.13				SD-76985-003	
						1 PLACE ± 0.25				DOC TYPE DOC PART REVISION	
						0 PLACES ±				PSD 001 E1	
						DRAFT WHERE APPLICABLE MUST REMAIN WITHIN DIMENSIONS				MATERIAL NUMBER CUSTOMER SHEET NUMBER	
						THIRD ANGLE PROJECTION				SEE CHART GENERAL MARKET 2 OF 4	
						DRAWING SERIES					
						C-SIZE 76985					

ORTHO PIN MAPPING

OPTION 270 (NEARSIDE - FAR SIDE)

A1-A1	A2-B1	A3-D1	A4-E1	A5-G1	A6-H1	A7-K1	A8-L1	A9-N1	A10-P1
B1-A2	B2-C1	B3-D2	B4-F1	B5-G2	B6-J1	B7-K2	B8-M1	B9-N2	B10-Q1
C1-B2	C2-C2	C3-E2	C4-F2	C5-H2	C6-J2	C7-L2	C8-M2	C9-P2	C10-Q2
D1-A3	D2-B3	D3-D3	D4-E3	D5-G3	D6-H3	D7-K3	D8-L3	D9-N3	D10-P3
E1-A4	E2-C3	E3-D4	E4-F3	E5-G4	E6-J3	E7-K4	E8-M3	E9-N4	E10-Q3
F1-B4	F2-C4	F3-E4	F4-F4	F5-H4	F6-J4	F7-L4	F8-M4	F9-P4	F10-Q4
G1-A5	G2-B5	G3-D5	G4-E5	G5-G5	G6-H5	G7-K5	G8-L5	G9-N5	G10-P5
H1-A6	H2-C5	H3-D6	H4-F5	H5-G6	H6-J5	H7-K6	H8-M5	H9-N6	H10-Q5
J1-B6	J2-C6	J3-E6	J4-F6	J5-H6	J6-J6	J7-L6	J8-M6	J9-P6	J10-Q6
K1-A7	K2-B7	K3-D7	K4-E7	K5-G7	K6-H7	K7-K7	K8-L7	K9-N7	K10-P7
L1-A8	L2-C7	L3-D8	L4-F7	L5-G8	L6-J7	L7-K8	L8-M7	L9-N8	L10-Q7
M1-B8	M2-C8	M3-E8	M4-F8	M5-H8	M6-J8	M7-L8	M8-M8	M9-P8	M10-Q8
N1-A9	N2-B9	N3-D9	N4-E9	N5-G9	N6-H9	N7-K9	N8-L9	N9-N9	N10-P9
P1-A10	P2-C9	P3-D10	P4-F9	P5-G10	P6-J9	P7-K10	P8-M9	P9-N10	P10-Q9
Q1-B10	Q2-C10	Q3-E10	Q4-F10	Q5-H10	Q6-J10	Q7-L10	Q8-M10	Q9-P10	Q10-Q10

NOTE: PINOUTS SHOWN IN BALLOONS ARE GROUNDS.
PINOUTS SHOWN ARE FOR SQUARE (10 COLUMN) PATTERN ONLY.

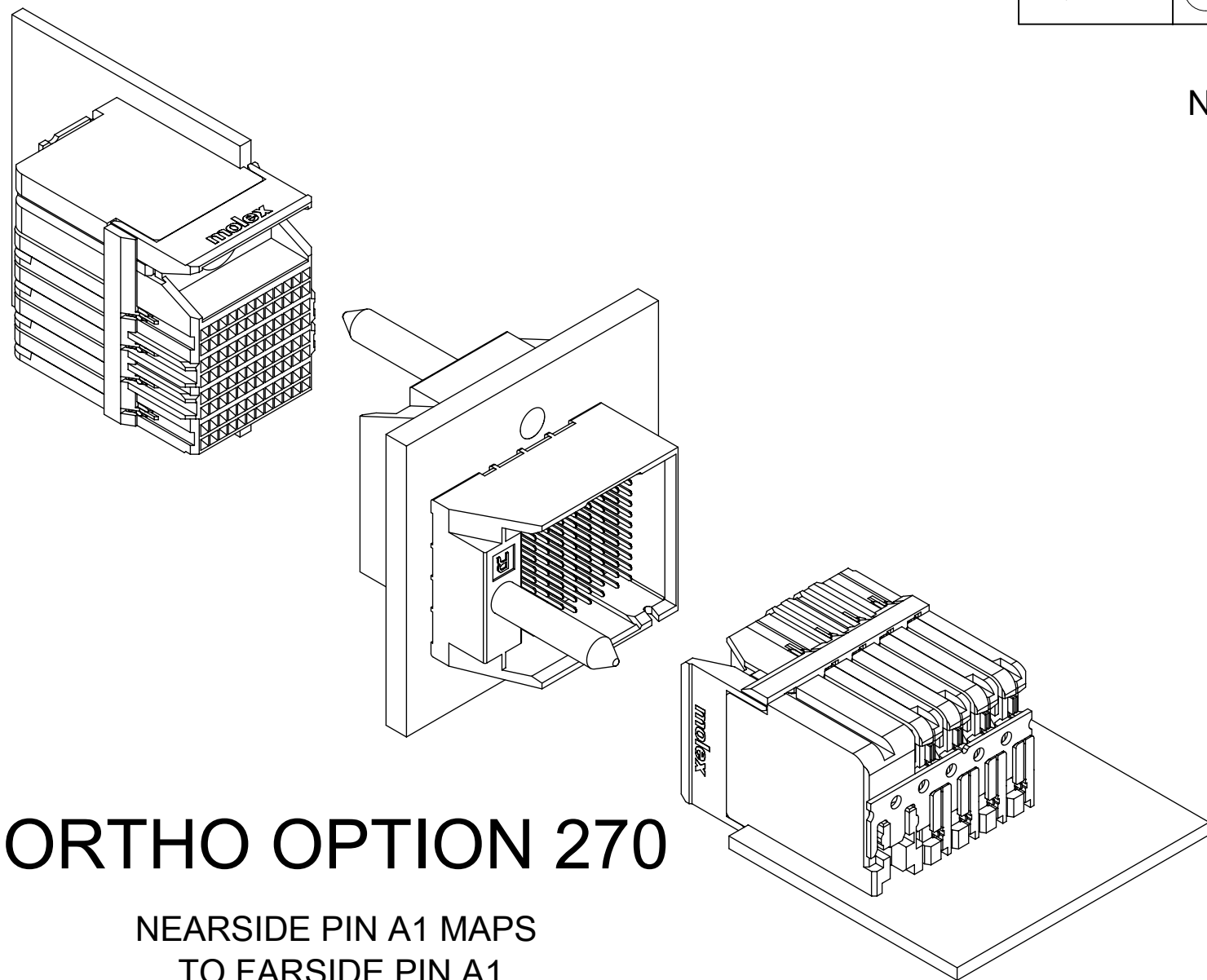

ORTHO OPTION 270
NEARSIDE PIN A1 MAPS
TO FAR SIDE PIN A1

SYMBOLS										THIS DRAWING CONTAINS INFORMATION THAT IS PROPRIETARY TO MOLEX ELECTRONIC TECHNOLOGIES, LLC AND SHOULD NOT BE USED WITHOUT WRITTEN PERMISSION									
DIMENSION UNITS		SCALE		CURRENT REV DESC: MIGRATED TO NX															
mm		8:1		<p>EC NO: 609931</p> <p>DRWN: JKUMARSARAFS 2018/10/18</p> <p>CHK'D: ABN 2019/01/04</p> <p>APPR: CWANG25 2019/01/11</p> <p>INITIAL REVISION:</p> <p>DRWN: JLAURX 4/28/09</p> <p>APPR: JBINGHAM 2010/01/14</p>															
GENERAL TOLERANCES (UNLESS SPECIFIED)																			
ANGULAR TOL ± 0.5°																			
4 PLACES ±																			
3 PLACES ±																			
2 PLACES ± 0.13																			
1 PLACE ± 0.25																			
0 PLACES ±																			
DRAFT WHERE APPLICABLE MUST REMAIN WITHIN DIMENSIONS		THIRD ANGLE PROJECTION		DRAWING		SERIES		MATERIAL NUMBER		CUSTOMER		DOC TYPE		DOC PART		REVISION			
		C-SIZE		76985		SEE CHART		GENERAL MARKET		PSD		001		E1		3 OF 4			

ORTHO PIN MAPPING

OPTION 90 (NEAR SIDE - FAR SIDE)

A1-Q10	A2-P10	A3-M10	A4-L10	A5-J10	A6-H10	A7-F10	A8-E10	A9-C10	A10-B10
B1-Q9	B2-N10	B3-M9	B4-K10	B5-J9	B6-G10	B7-F9	B8-D10	B9-C9	B10-A10
C1-P9	C2-N9	C3-L9	C4-K9	C5-H9	C6-G9	C7-E9	C8-D9	C9-B9	C10-A9
D1-Q8	D2-P8	D3-M8	D4-L8	D5-J8	D6-H8	D7-F8	D8-E8	D9-C8	D10-B8
E1-Q7	E2-N8	E3-M7	E4-K8	E5-J7	E6-G8	E7-F7	E8-D8	E9-C7	E10-A8
F1-P7	F2-N7	F3-L7	F4-K7	F5-H7	F6-G7	F7-E7	F8-D7	F9-B7	F10-A7
G1-Q6	G2-P6	G3-M6	G4-L6	G5-J6	G6-H6	G7-F6	G8-E6	G9-C6	G10-B6
H1-Q5	H2-N6	H3-M5	H4-K6	H5-J5	H6-G6	H7-F5	H8-D6	H9-C5	H10-A6
J1-P5	J2-N5	J3-L5	J4-K5	J5-H5	J6-G5	J7-E5	J8-D5	J9-B5	J10-A5
K1-Q4	K2-P4	K3-M4	K4-L4	K5-J4	K6-H4	K7-F4	K8-E4	K9-C4	K10-B4
L1-Q3	L2-N4	L3-M3	L4-K4	L5-J3	L6-G4	L7-F3	L8-D4	L9-C3	L10-A4
M1-P3	M2-N3	M3-L3	M4-K3	M5-H3	M6-G3	M7-E3	M8-D3	M9-B3	M10-A3
N1-Q2	N2-P2	N3-M2	N4-L2	N5-J2	N6-H2	N7-F2	N8-E2	N9-C2	N10-B2
P1-Q1	P2-N2	P3-M1	P4-K2	P5-J1	P6-G2	P7-F1	P8-D2	P9-C1	P10-A2
Q1-P1	Q2-N1	Q3-L1	Q4-K1	Q5-H1	Q6-G1	Q7-E1	Q8-D1	Q9-B1	Q10-A1

NOTE: PINOUTS SHOWN IN BALLOONS ARE GROUNDS.
PINOUTS SHOWN ARE FOR SQUARE (10 COLUMN) PATTERNS ONLY.

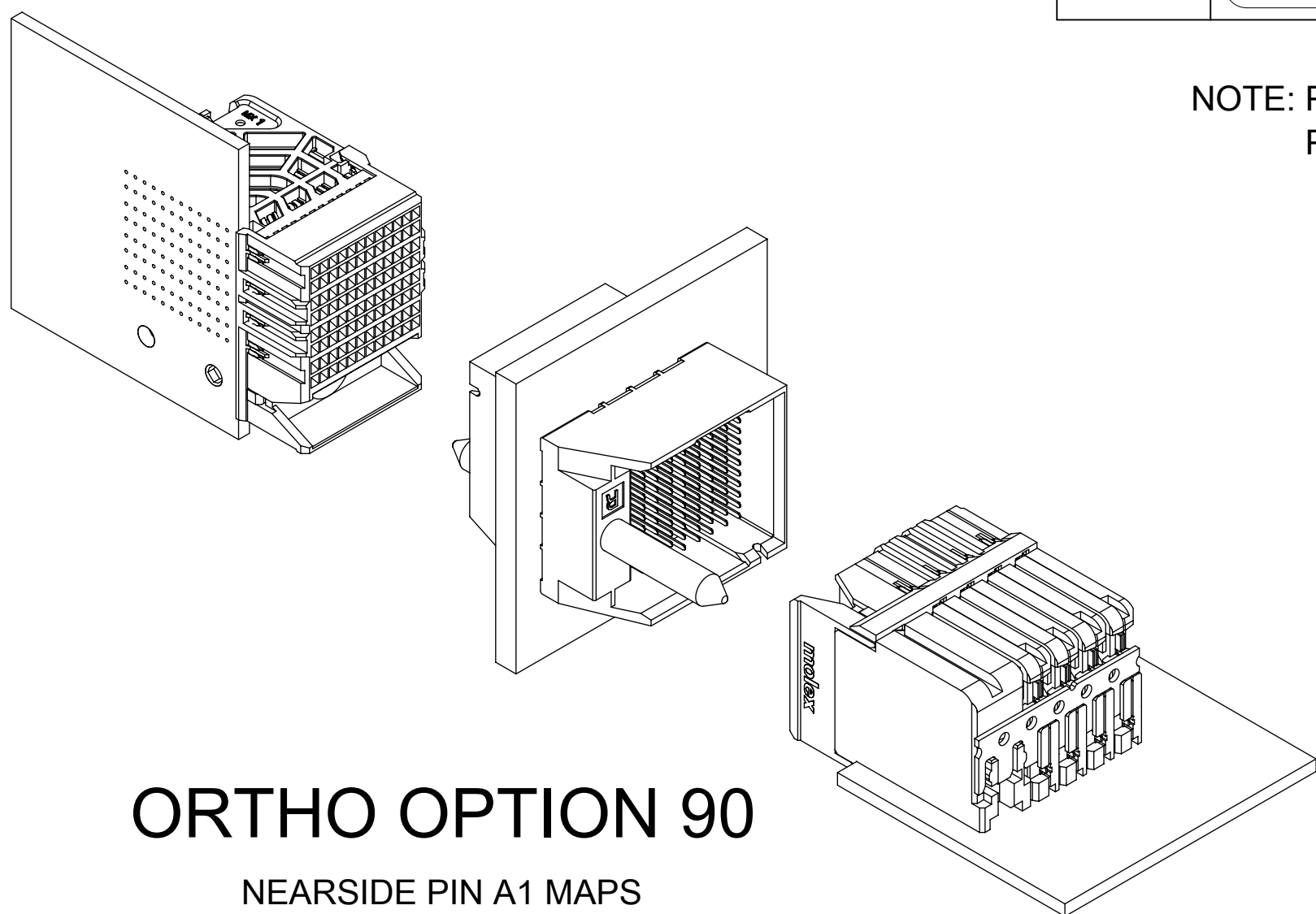

ORTHO OPTION 90

NEAR SIDE PIN A1 MAPS TO FAR SIDE PIN Q10 (FOR SQUARE PATTERN)

THIS DRAWING CONTAINS INFORMATION THAT IS PROPRIETARY TO MOLEX ELECTRONIC TECHNOLOGIES, LLC AND SHOULD NOT BE USED WITHOUT WRITTEN PERMISSION									
SYMBOLS DIMENSION UNITS: mm SCALE: 4:1 GENERAL TOLERANCES (UNLESS SPECIFIED): ANGULAR TOL: ± 0.5° 4 PLACES: ± 3 PLACES: ± 2 PLACES: ± 0.13 1 PLACE: ± 0.25 0 PLACES: ± DRAFT WHERE APPLICABLE MUST REMAIN WITHIN DIMENSIONS		CURRENT REV DESC: MIGRATED TO NX EC NO: 609931 DRWN: JKUMARSARAFS 2018/10/18 CHK'D: ABN 2019/01/04 APPR: CWANG25 2019/01/11 INITIAL REVISION: DRWN: JLAURX 4/28/09 APPR: JBINGHAM 2010/01/14							
DOCUMENT STATUS: P1 RELEASE DATE: 2019/01/11 07:48:14		PRODUCT CUSTOMER DRAWING DOCUMENT NUMBER: SD-76985-003 DOC TYPE: PSD DOC PART: 001 REVISION: E1				MATERIAL NUMBER: SEE CHART CUSTOMER: GENERAL MARKET SHEET NUMBER: 4 OF 4			