

THIS DRAWING IS UNPUBLISHED. RELEASED FOR PUBLICATION
 © COPYRIGHT - By - ALL RIGHTS RESERVED.

LOC		DIST		REVISIONS			
P	LTR	DESCRIPTION		DATE	DWN	APVD	
B		ECR-13-018647		14MAR2014	W.W	C.W	

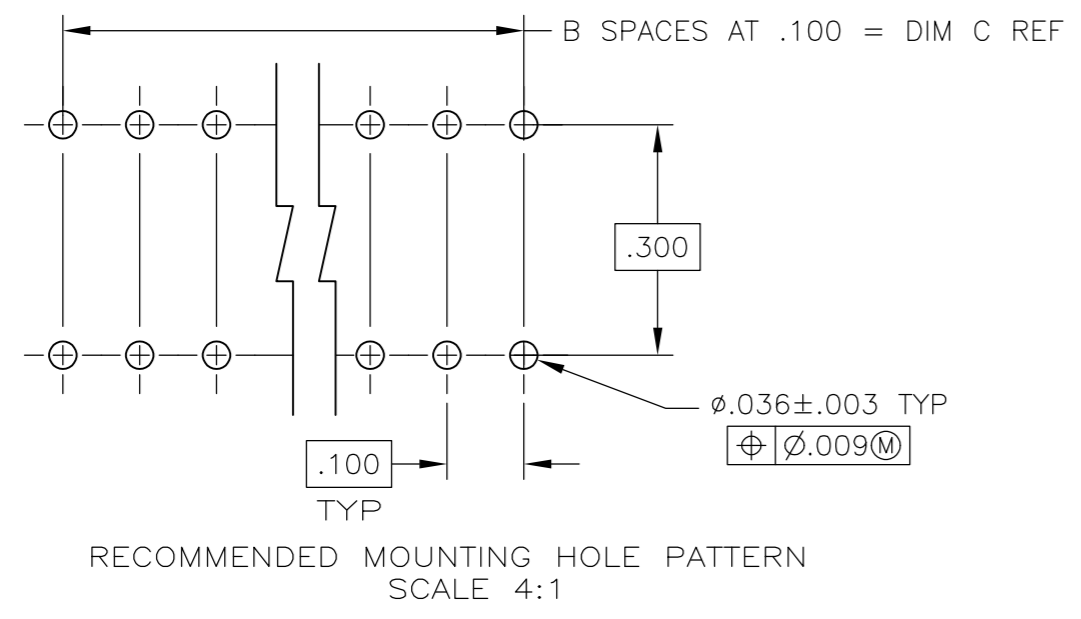
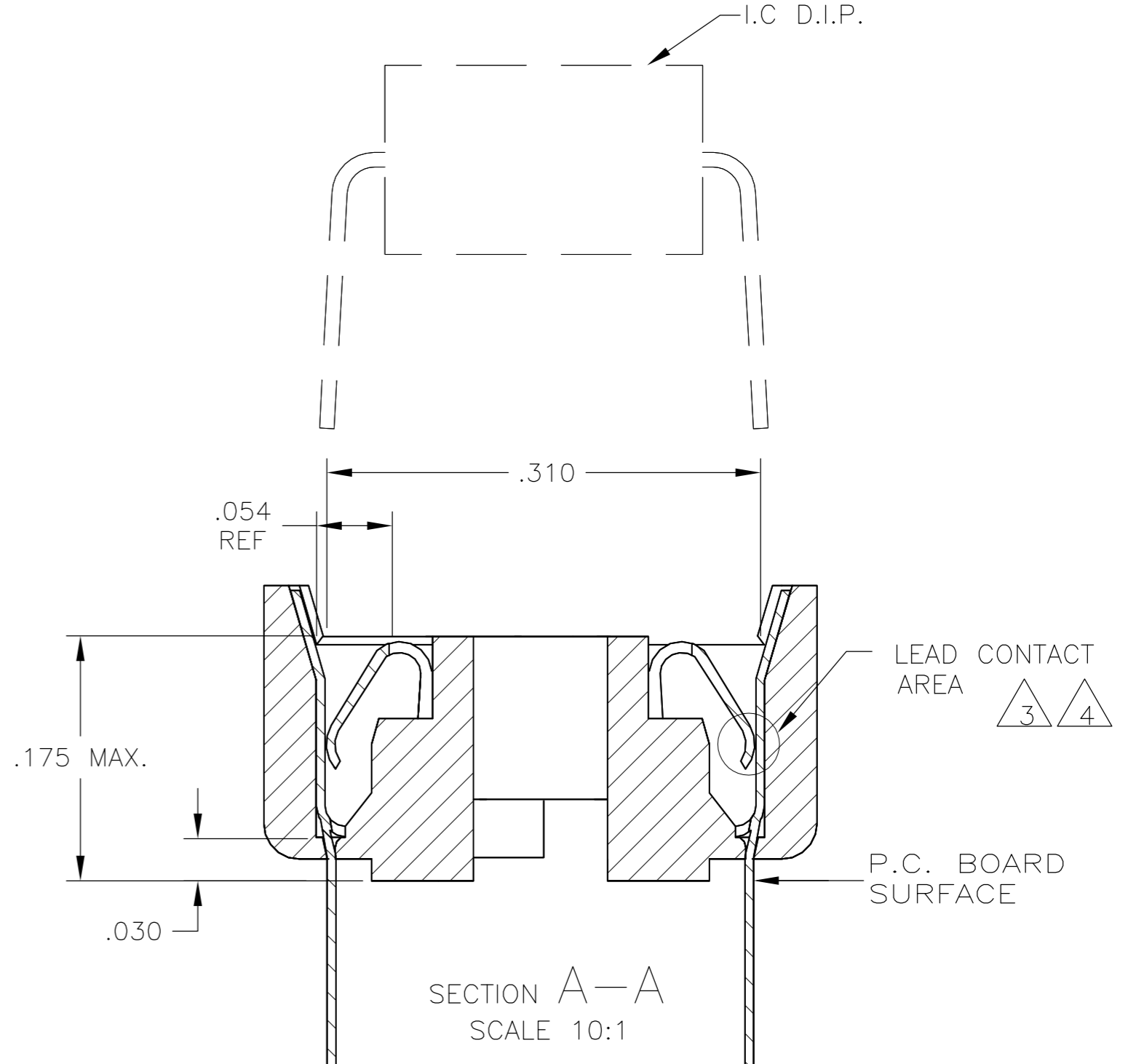
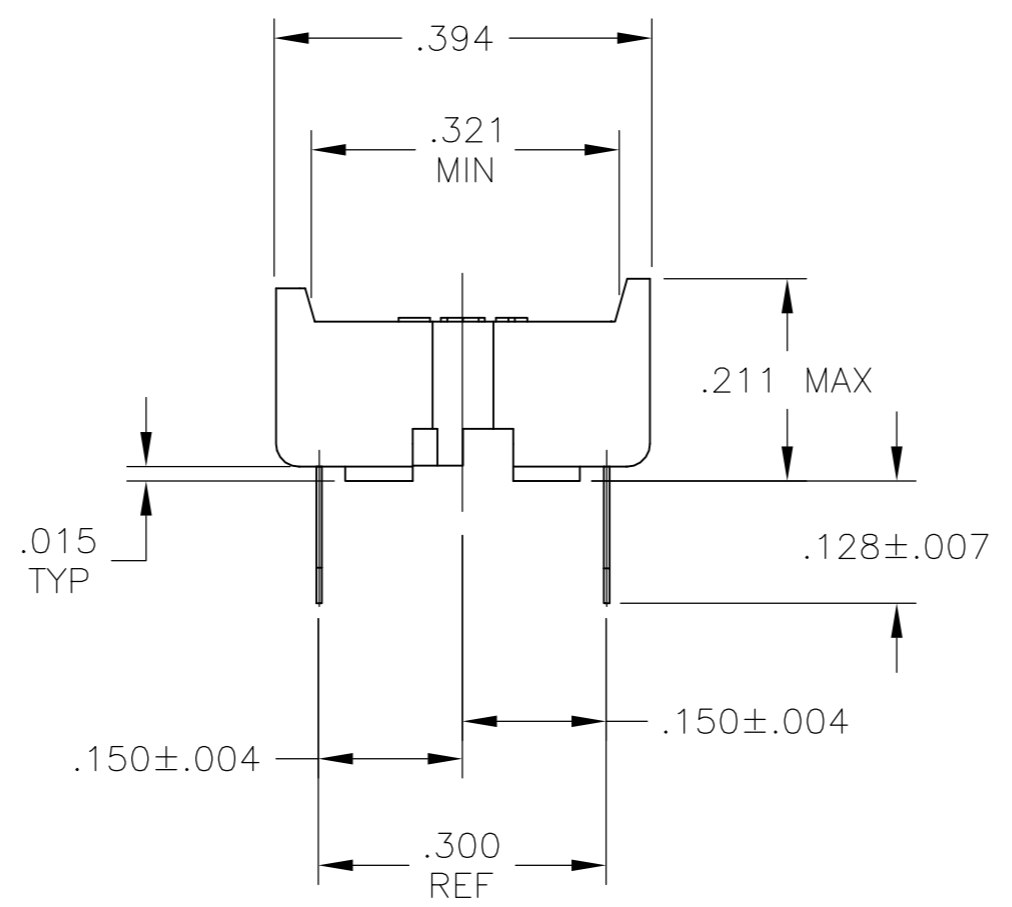
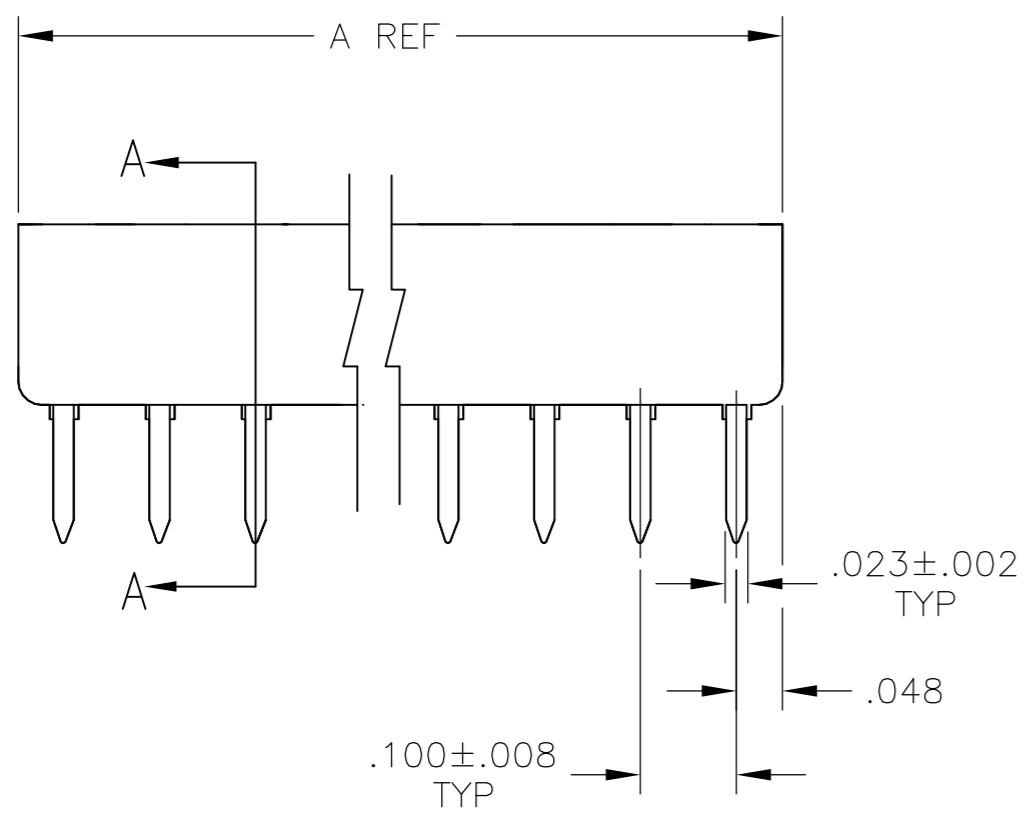
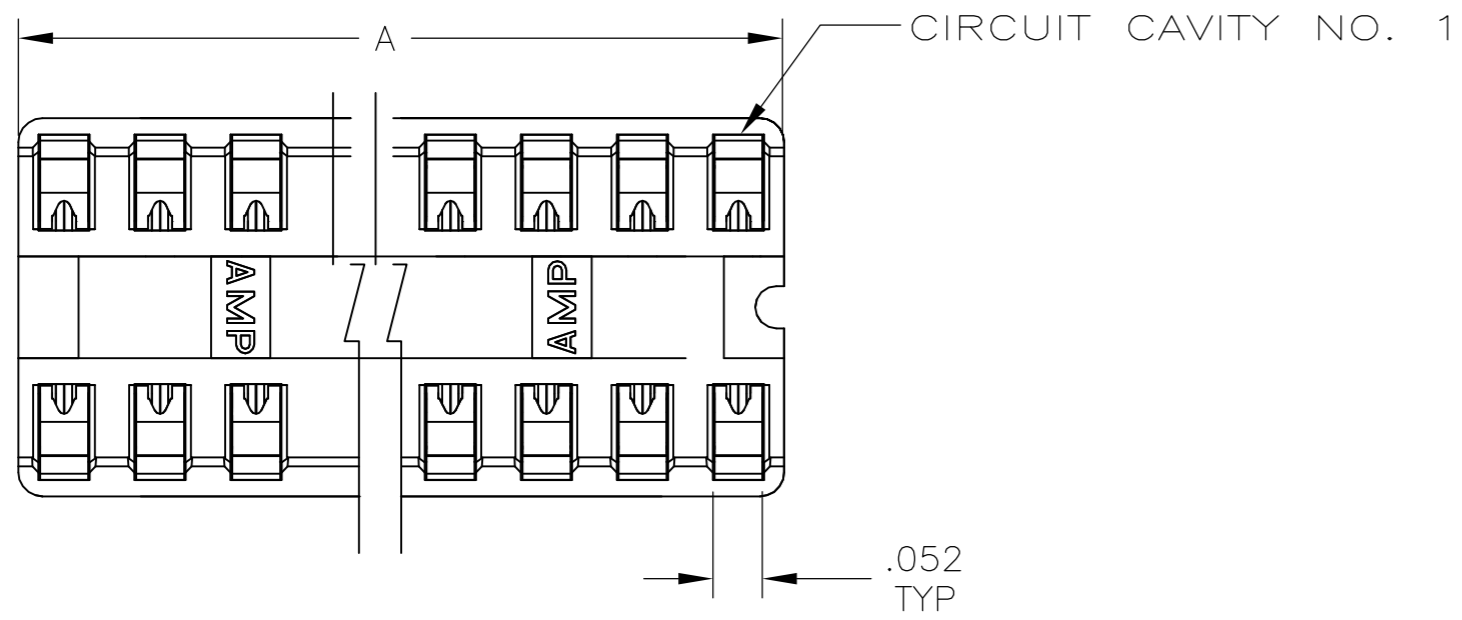

- 1 RECEPTACLE ACCEPTS A .008-.014 THICK I.C. LEAD.
- 2 TUBE LOADED FOR AUTOMATIC INSERTION.
- 3 BECU CONTACT - PLATED WITH TWO .000030 MIN THK. GOLD STRIPES IN CONTACT AREA WITH TIN ON CONTACT LEGS, BALANCE OF CONTACT NICKEL PLATED.
- 4 PHOS. BRZ CONTACT - PLATED WITH TWO .000015 MIN THK. GOLD STRIPES IN CONTACT AREA WITH TIN ON CONTACT LEGS, BALANCE OF CONTACT NICKEL PLATED.
- 5 GLASS FILLED THERMOPLASTIC, 94V-0, BLACK

CONTACT & FINISH	DIM. C	B	SPCS	DIM. A	POSITION	PART NO.
(B) OBSOLETE	3	1.100	11	1.195	24	1-1825094-7
(B) OBSOLETE	3	.900	9	.995	20	1-1825094-6
(B) OBSOLETE	3	.800	8	.895	18	1-1825094-5
(B) OBSOLETE	3	.700	7	.795	16	1-1825094-4
(B) OBSOLETE	3	.600	6	.695	14	1-1825094-3
(B) OBSOLETE	3	.300	3	.395	8	1-1825094-2
(B) OBSOLETE	3	.200	2	.295	6	1-1825094-1
(B) OBSOLETE	4	1.100	11	1.195	24	1825094-7
(B) OBSOLETE	4	.900	9	.995	20	1825094-6
(B) OBSOLETE	4	.800	8	.895	18	1825094-5
(B) OBSOLETE	4	.700	7	.795	16	1825094-4
(B) OBSOLETE	4	.600	6	.695	14	1825094-3
(B) OBSOLETE	4	.300	3	.395	8	1825094-2
(B) OBSOLETE	4	.200	2	.295	6	1825094-1

THIS DRAWING IS A CONTROLLED DOCUMENT.

DIMENSIONS: INCHES	TOLERANCES UNLESS OTHERWISE SPECIFIED:	DWN: B.S.VISWESWARA	21APR05	TE Connectivity	
	0 PLC ± -	CHK: K WRIGHT		DIP SOCKET ASSY, LADDER, DIPLOMATE, .300 CL, LEAD FREE	
	1 PLC ± -	APVD: -		SIZE: A2	CAGE CODE: 00779
	2 PLC ± -	PRODUCT SPEC: 108-1066		DRAWING NO: C=1825094	RESTRICTED TO: -
	3 PLC ± .005	APPLICATION SPEC: 114-1049		SCALE: 5:1	SHEET: 1 of 1
	4 PLC ± -	WEIGHT: -			REV: B
MATERIAL: SEE TABLE	FINISH: SEE TABLE	CUSTOMER DRAWING			