

DRAWING MADE IN THIRD ANGLE PROJECTION

PART NUMBER	REV	FIRST USED	FEED TYPE
567426 -1	B	LEADMAKER	MECH
567426 -2	B	AMP-O-ELECTRIC	MECH

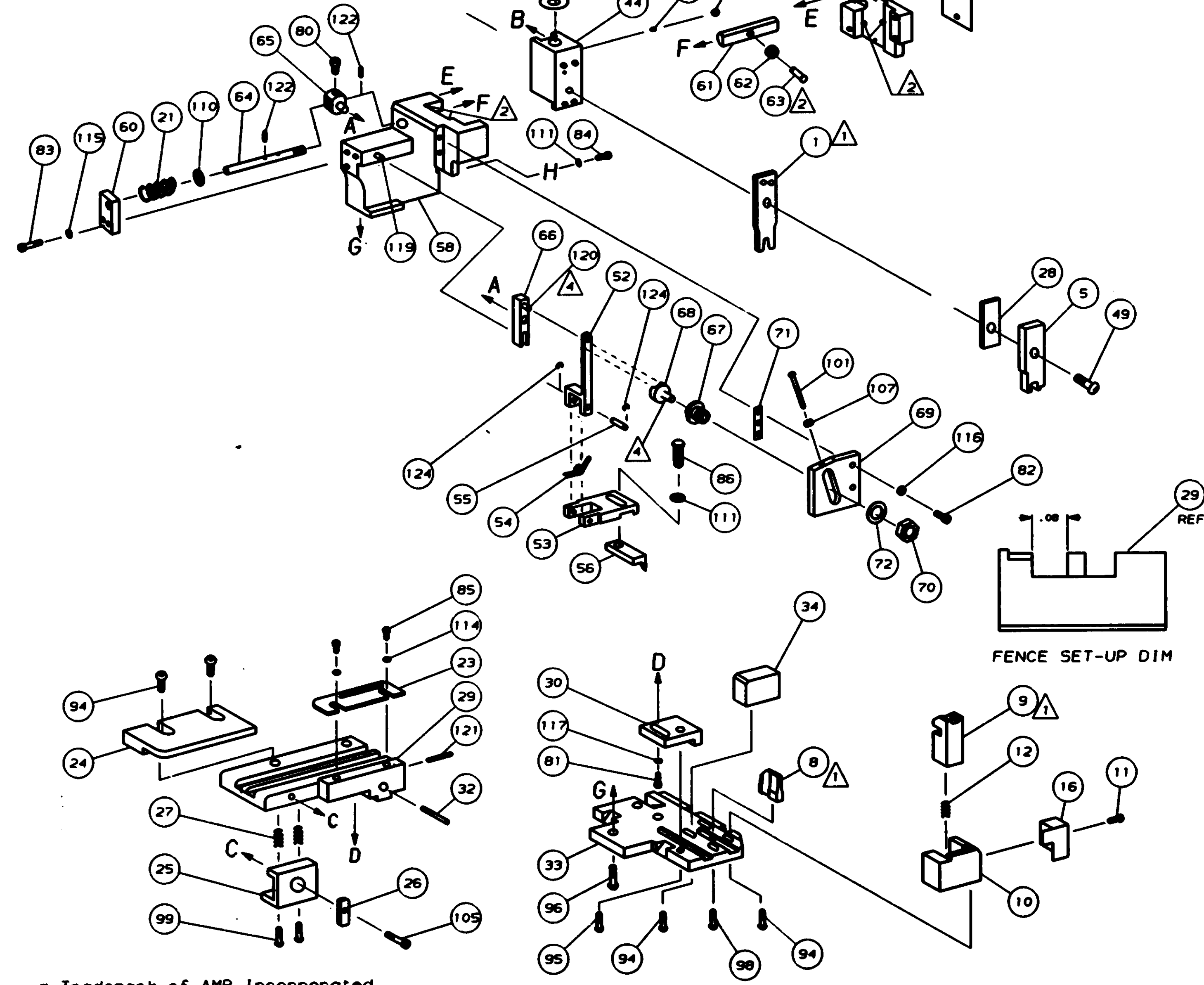
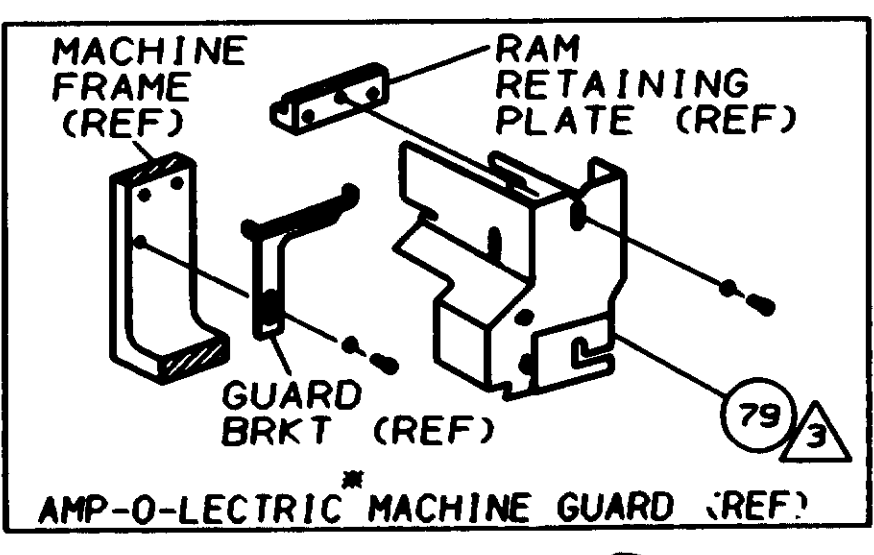
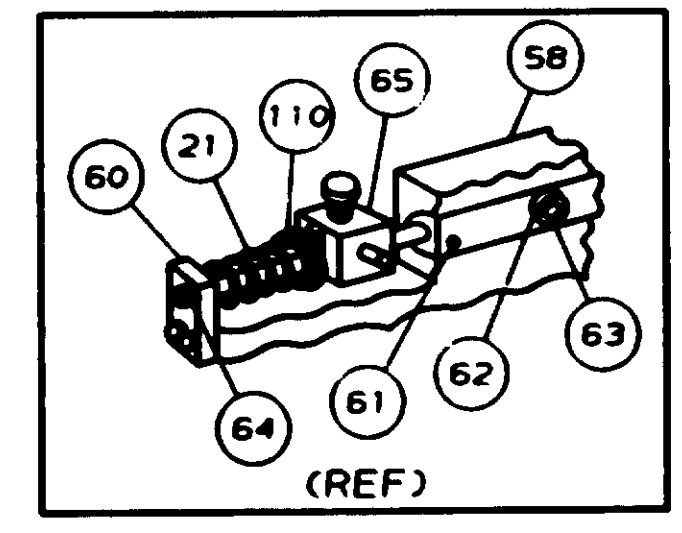

FENCE SET-UP DIM

- 1 RECOMMENDED SPARE PARTS.
 - 2 GREASE LIGHTLY.
 - 3 GUARD MUST BE IN PLACE WHEN OPERATING APPLICATOR IN AMP-O-ELECTRIC MACHINE.
 - 4 LUBRICATE DAILY USING NO. 20 MACHINE OIL.
5. ITEMS WITH QTY OF REF SPECIFIED (EXCEPT ITEM 79) ARE USED ON ITEM 46.

REF	REF	-	A	21045-3	RING, RET "C" (#.187) FD FINE PIN	124
REF	REF	-	A	5-21028-1	PIN, SLT SPR (#.125x.50) ADJ ROD	122
1	1	-	A	4-21028-0	PIN, SLT SPR (#.093x.75) ST GDE PL	121
REF	REF	-	A	1-21030-1	PIN, DOWEL (#.187x.50) LEVER	120
REF	REF	-	A	1-21030-6	PIN, DOWEL (#.187x.25) HOUSING	119
1	1	-	A	21024-5	WASHER, LOCK (#10) ADJ BLOCK	117
REF	REF	-	A	21024-5	WASHER, LOCK (#10) ADJ PLATE	116
REF	REF	-	A	21024-5	WASHER, LOCK (#10) FEED GDE ROD	115
2	2	-	A	21024-2	WASHER, LOCK (#4) FRONT STP GUIDE	114
2	2	-	A	21024-4	WASHER, LOCK (#8) STRIPPER	111
REF	REF	-	A	21899-4	WASHER, FLAT (#5/16) SCREW ADJ	110
REF	REF	-	A	21018-5	NUT, HEX (6-32) FEED ADJ	107
1	1	-	A	22353-8	SCR, SHLD (#.187x.25) DRAG LEVER	105
1	-	-	A	456567-1	SCR, SHLD (#.188x.12) STRIP	104
1	1	-	A	21009-2	SCR, SKT SET (1/4-20x.25 LW) RAM	103
2	2	-	A	21017-2	SCR, DRIVE (#2x.19) ID PLATE	102
REF	REF	-	A	6-23715-5	SCR, PAN HD (6-32x1.50) FEED ADJ	101
1	1	-	B	461264-1	PLATE, IDENTIFICATION	100
2	2	-	A	2-21002-9	SCR, BHC (10-32x.75) DRAG	99
1	1	-	A	22733-8	SCR, BHC (8-32x.38 LW) ANVIL	98
REF	REF	-	A	2-21002-9	SCR, BHC (10-32x.75) CAP	97
REF	REF	-	A	2-22733-8	SCR, BHC (1/4-20x.62) HOUSING	96
REF	REF	-	A	2-21002-7	SCR, BHC (10-32x.50) SG ADJ BLOCK	95
6	6	-	A	2-21002-2	SCR, BHC (8-32x.50) SHEAR	94
1	1	-	A	1-21002-7	SCR, BHC (6-32x.38) CAM	91
1	1	-	A	2-22603-0	SCR, HEX HD (8-32x.31) FEED FINGER	86
2	2	-	A	1-21000-3	SCR, SHC (4-40x.25) F ST GUIDE	85
1	1	-	A	2-21000-7	SCR, SHC (8-32x.50) STRIPPER	84
REF	REF	-	A	3-21000-7	SCR, SHC (10-32x.75) FEED ROD GD	83
REF	REF	-	A	3-21000-6	SCR, SHC (10-32x.62) FD ADJ BLK	82
1	1	-	A	3-21000-4	SCR, SHC (10-32x.38) SG ADJ BL	81
REF	REF	-	A	3-21000-4	SCR, SHC (10-32x.38) PIVOT BLK	80
REF	-	-	B	455749-1	GUARD, WINDOW	79
1	1	-	A	690603-1	SPRING, ASSIST	74
1	1	-	A	23030-1	SCR, SHC (6-32x.25) CP DISC	73
REF	REF	-	A	458109-1	WASHER, SPECIAL	72
REF	REF	-	A	690517-1	SPACER	71

REF	REF	-	B	22594-8	NUT, HEX (1/2-20)	70
REF	REF	-	B	240628-1	PLATE, ADJUSTMENT	69
REF	REF	-	B	240626-1	SHAFT, PIVOT	68
REF	REF	-	B	240633-1	BUSHING	67
REF	REF	-	A	455680-1	LEVER, INTERMEDIATE	66
REF	REF	-	B	240629-1	BLOCK, PIVOT	65
REF	REF	-	A	240632-2	SCREW, ADJ FEED ROD	64
REF	REF	-	B	240659-3	PIN, CAM ROLLER	63
REF	REF	-	B	240658-1	ROLLER, CAM	62
REF	REF	-	B	454398-2	ROD, FEED	61
REF	REF	-	A	454178-1	GUIDE, FEED ROD	60
REF	REF	-	C	454220-1	CAP, RAM	59
REF	REF	-	D	454485-1	HOUSING	58
1	1	-	B	690542-2	PAWL, FEED	56
REF	REF	-	B	240624-1	PIN, FEED FINGER	55
REF	REF	-	B	691499-1	SPRING, FEED FINGER	54
REF	REF	-	B	690541-1	FINGER, FEED	53
REF	REF	-	A	455679-1	LEVER, TERMINAL FEED ARM	52
1	1	-	A	7-21002-9	BOLT, CRIMPER (5/16x1.00)	49
1	-	-	B	690602-5	CAM, PRE-FEED 1 1/8 ST	48
-	1	-	B	690501-4	CAM, POST-FEED 1 5/8 ST	47
1	1	-	B	459456-1	APPLICATOR, BASIC (SUBASSY)	46
1	1	-	A	690191-1	PLUG, NYLON	45
1	1	-	C	455673-1	RAM	44
1	1	-	A	690125-1	WASHER, LAMINATED	43
1	1	-	A	690124-1	WASHER, RAM	42
1	1	-	A	690223-1	DISC, SPACER	41
1	1	-	A	23241-6	BALL, STEEL	40
1	1	-	A	690170-1	SPRING, COMPRESSION	39
1	1	-	B	690141-5	DISC, WIRE	37
1	1	-	A	22480-5	WASHER, SPRING	36
1	1	-	B	690212-1	POST, RAM	35
1	1	-	B	1-690786-0	SUPPORT, TERMINAL	34
REF	REF	-	D	455675-1	PLATE, BASE	33
1	1	-	A	690432-3	SCREW, ADJUSTMENT	32
REF	REF	-	B	455689-1	BLOCK, STRIP GUIDE ADJ	30
1	1	-	C	843869-2	PLATE, STRIP GUIDE	29
1	1	-	C	1-455888-5	SPACER, FRONT SHEAR DEP	28
2	2	-	A	1-22284-0	SPRING, DRAG	27
1	1	-	B	240793-1	LEVER, DRAG RELEASE	26
1	1	-	B	240792-1	DRAG, TERMINAL	25
1	1	-	D	6-690504-8	GUIDE, STRIP (REAR)	24
1	1	-	A	690438-1	GUIDE, STRIP (FRONT)	23
-	1	-	B	690472-2	STRIPPER	22
REF	REF	-	A	4-22284-9	SPRING, FEED RETURN	21
1	-	-	B	458950-1	STRIPPER, WIRE STOP	20
1	-	-	B	458949-1	STRIPPER	19
1	1	-	B	691667-1	GUARD, CHIP (FRONT)	16
1	1	-	C	456406-8	CRIMPER, WIRE	1

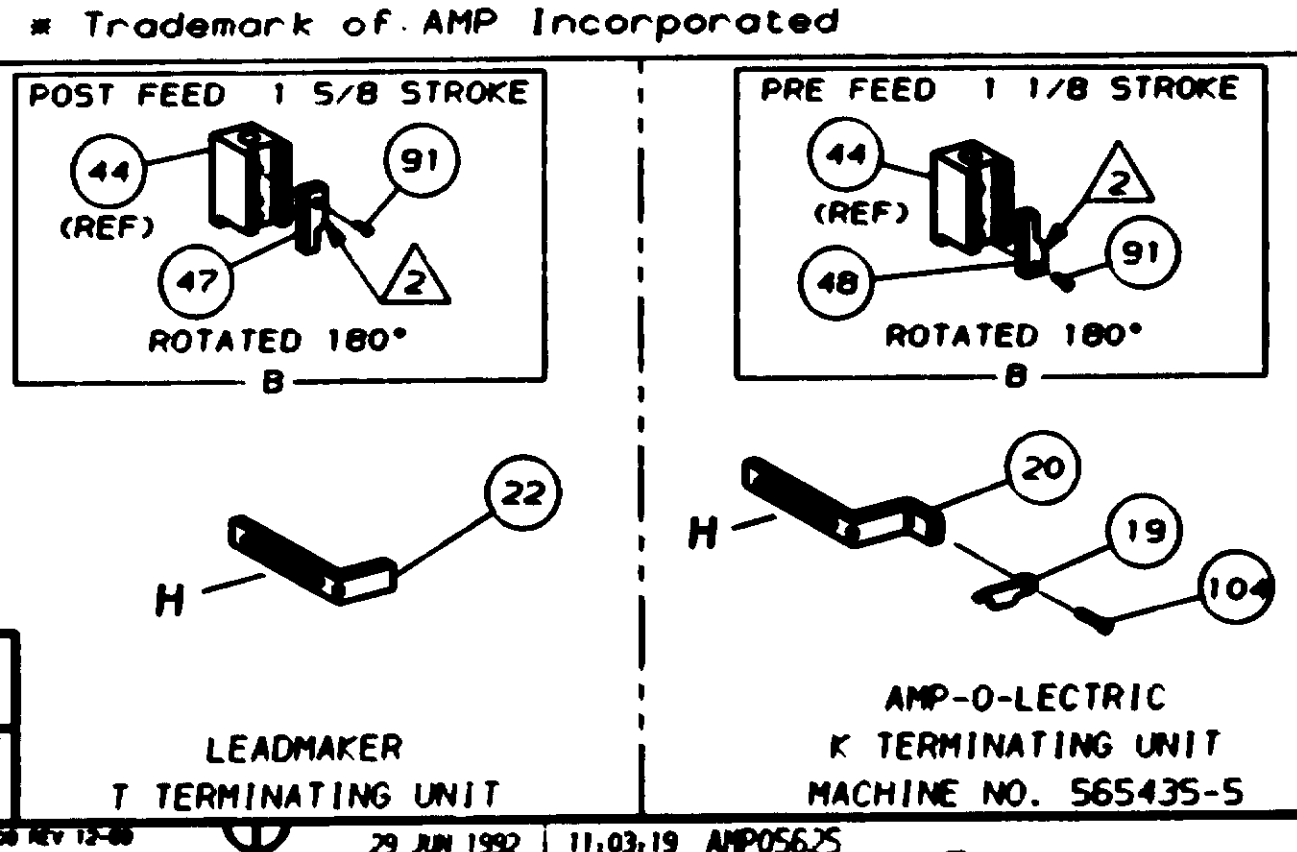

PAD LTR	CRIMP HEIGHT	WIRE SIZE	WIRE STRIP LENGTH
A	.053	18	
B	.048	20	
C	.044	22	
D	NOT USED		

CRIMP	SIZE	TYPE	FEED	APPL INST
WIRE	.090	F	.480	A1 8040
INSUL	-	-	-	-

WIRE RANGE	INSULATION RANGE	SET UP GAGE	LAYOUT
22-18	-	458637-1	L1431

TERMINAL NAME: 4MM DIA RIGHT ANGLE PIN RECPT

QTY	REV	U/M	DWG SIZE	PART NO	DESCRIPTION	ITEM NO
-2	-1					

QTY	REV	U/M	DWG SIZE	PART NO	DESCRIPTION	ITEM NO
-2	-1					

REVISION RECORD

REV	DATE	DESCRIPTION
B	EON A-376092	
A	REVISED	

SCALE: D DWG NO: 567426

MACHINE REF: MINI APPL

SHEET: 1 of 1

THIS INFORMATION IS UNCLASSIFIED AND IS RELEASED TO YOU ON COMPLETION OF THE DECLASSIFICATION PROCESS. NO FURTHER DISCLOSURE IS MADE BY YOU TO OTHER THAN THE PERSONNEL AT THE WRITER AUTHORITY. INFORMATION SHOWS INCORPORATED. WATERGATE, PA.