

REVISIONS					
P	LTR	DESCRIPTION	DATE	DWN	APVD
B		REVISED (ECR-19-014755)	23SEP2019	CI	YJ
BI		REVISED (ECR-20-006211)	29APR2019	CI	YJ
C		REVISED (ECR-23-167452)	10FEB2023	CI	YJ
CI		REVISED (ECR-23-176535)	25MAY2023	CI	YJ

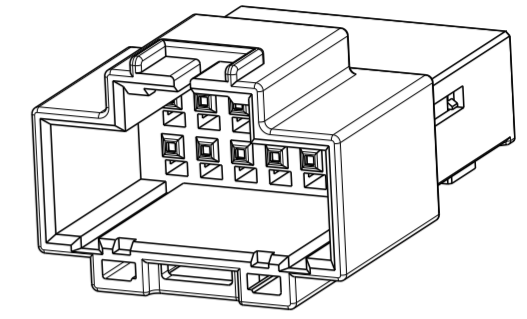

ISO VIEW

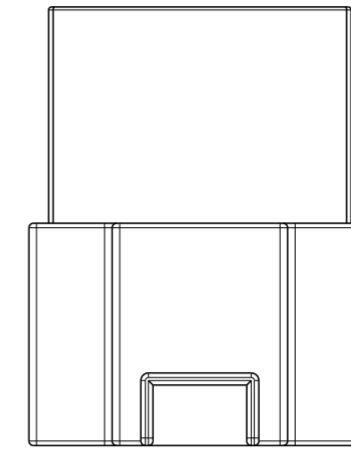
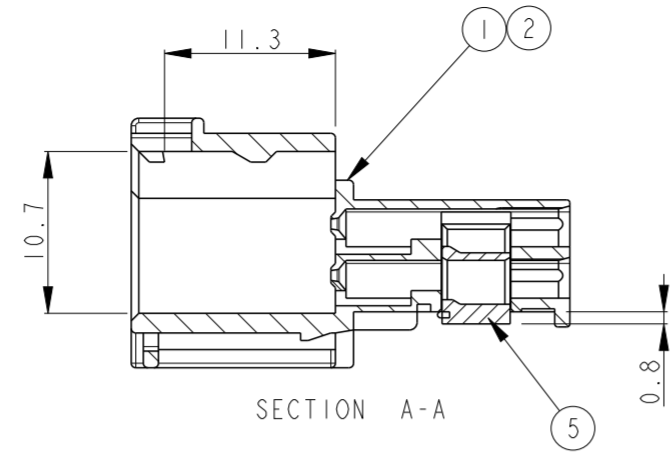
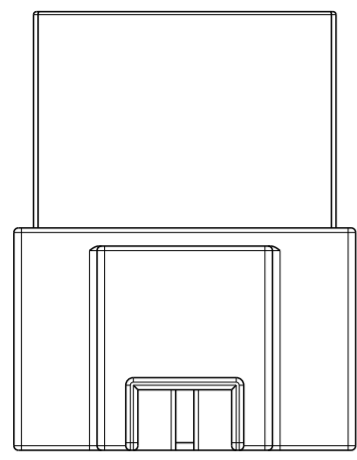
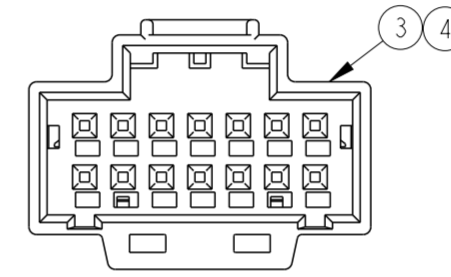
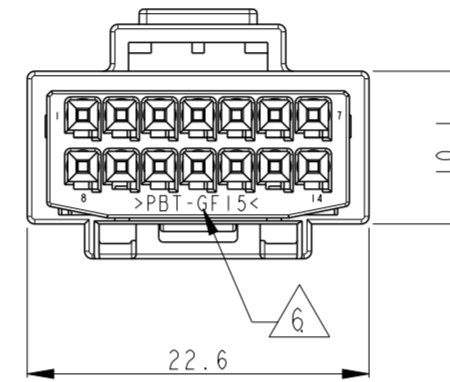
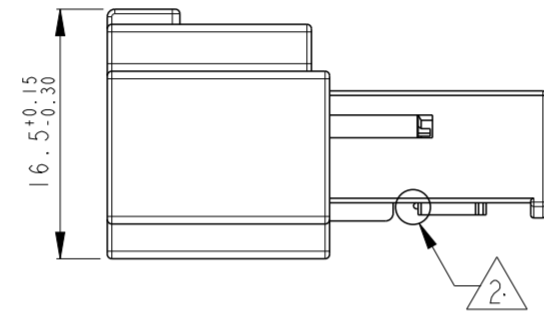
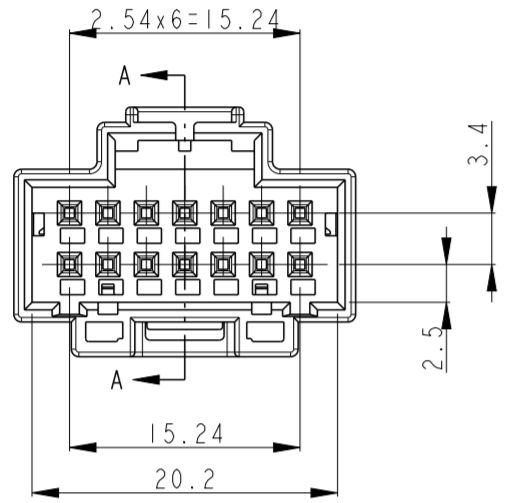

<ONLY FOR P/N:2-936126-3, 3-936126-4>

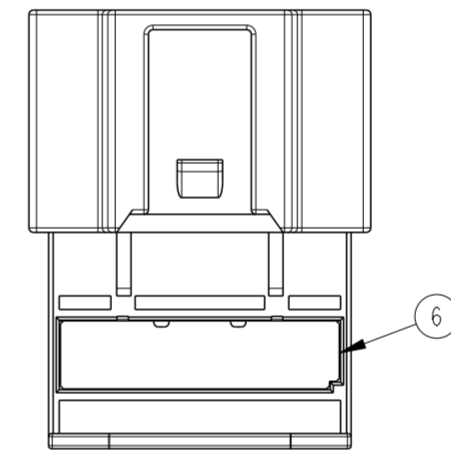
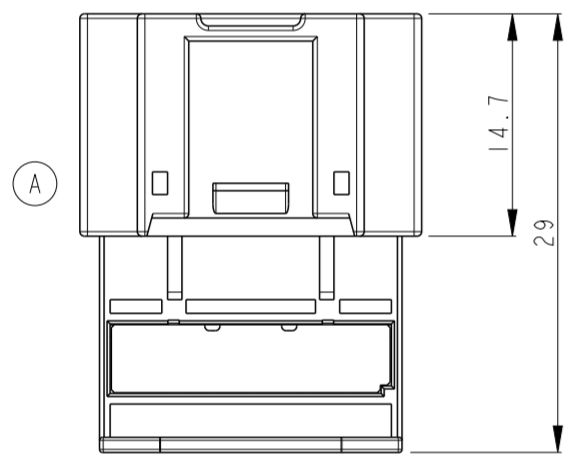

KEY CODE

CODE 1: 0-936126-1
0-936126-2

CODE 1: 2-936126-3

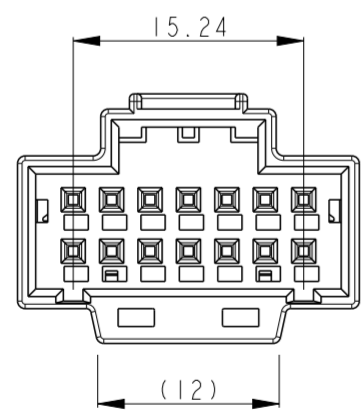
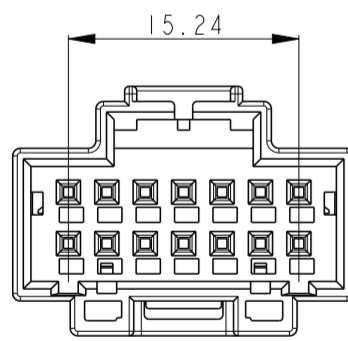

CODE 2 : 3-936126-4

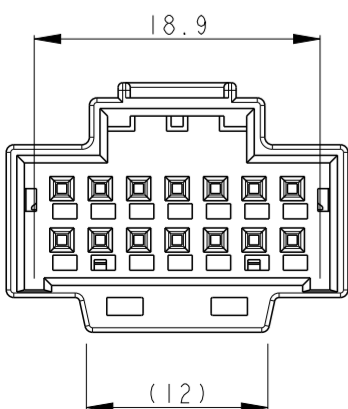

NOTE
 1.GENERAL TOLRANCE : ±0.3,±1°
 2.CONDITION OF DELIVERY, DBL IN 1ST LOCKING POSITION.
 3.APPLIED CLIP HSG:

P/N.	PANEL THK.	PANEL HOLE SIZE
368165	0.7~1.6mm	Ø7±0.1
368373	0.5~2.0mm	Ø7±0.1

4.APPLIED PLUG ASSY P/N:936124
 5.APPLIED TAB CONTACT P/N:

P/N	928918	963716
WIRE SIZE(mm^)	0.25-0.5	0.75

6. RECYCLE MARK;
 - >PBT-GF15< : 0-936126-1, 0-936126-2
 - >PA66-GF15< : 2-936126-3, 3-936126-4

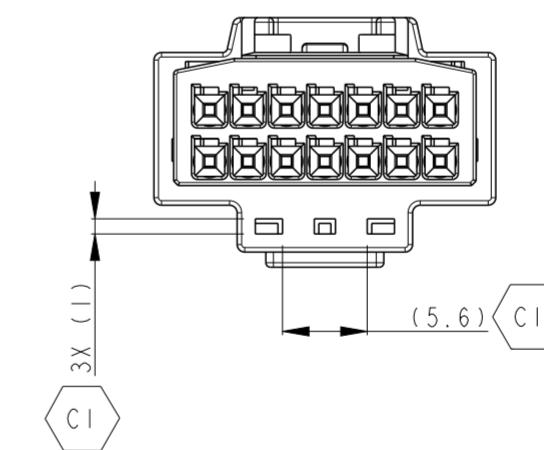

NO.	DESCRIPTION	MATERIAL	COLOR	Q'TY
6	DBL HSG	PA66-GF15	BLACK	I
5	DBL HSG	PBT-GF15	NATURAL	I
4	CAP HSG CODE2	PA66-GF15	BROWN	I
3	CAP HSG CODE1	PA66-GF15	DARK GRAY	I
2	CAP HSG CODE1	PBT-GF15	YELLOW	I
1	CAP HSG CODE1	PBT-GF15	BLACK	I

0-936126-1	MOS 14P CAP ASSY CODE1 (BLACK)
0-936126-2	MOS 14P CAP ASSY CODE1 (YELLOW)
2-936126-3	MOS 14P CAP ASSY CODE1 (DARK GRAY)
3-936126-4	MOS 14P CAP ASSY CODE2 (BROWN)

THIS DRAWING IS A CONTROLLED DOCUMENT.

DWN: HS BAE	CHK: BM JANG	APVD: CS LEE	PRODUCT SPEC
APPLICATION SPEC			
WEIGHT			
CUSTOMER DRAWING			

TE Connectivity

NAME: MOS 14P CAP ASSEMBLY

SIZE: A2 CAGE CODE: 00779 DRAWING NO: 936126

SCALE: 2:1 SHEET: 1 OF 1 REV: CI