

.040" NPN Phototransistors

Epoxy Lensed TO-106 Ceramic Package

VTT9102H, 9103H

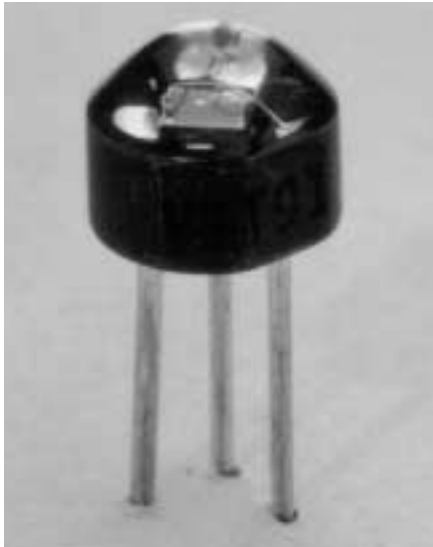

PACKAGE DIMENSIONS inch (mm)

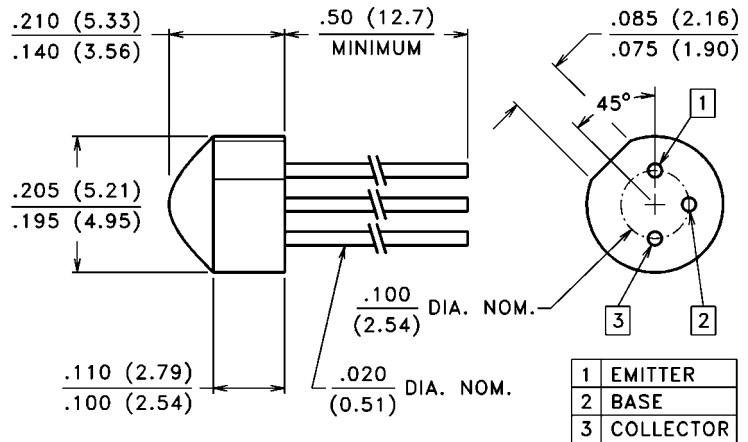

CASE 9 TO-106 (LENSED)
CHIP TYPE: 40T

PRODUCT DESCRIPTION

A medium area high sensitivity NPN silicon phototransistor in a recessed TO-106 ceramic package. The chip is protected with a lens of clear epoxy. The base connection is brought out allowing conventional transistor biasing. These devices are spectrally matched to any of PerkinElmer IREDS.

RoHS Compliant



ABSOLUTE MAXIMUM RATINGS ■

(@ 25°C unless otherwise noted)

Maximum Temperatures	
Storage Temperature:	-20°C to 70°C
Operating Temperature:	-20°C to 70°C
Continuous Power Dissipation:	100 mW
Derate above 30°C:	2.5 mW/°C
Maximum Current:	50 mA
Lead Soldering Temperature:	260°C
	(1.6 mm from case, 5 sec. max.)

ELECTRO-OPTICAL CHARACTERISTICS @ 25°C (See also typical curves, pages 91-92)

Part Number ■	Light Current		Dark Current	Collector Breakdown	Emitter Breakdown	Saturation Voltage	Rise/Fall Time	Angular Response $\theta_{1/2}$		
	I_C		I_{CEO}	$V_{BR(CEO)}$	$V_{BR(EO)}$	$V_{CE(SAT)}$	t_R/t_F			
	mA	H	H = 0	$I_C = 100 \mu A$ H = 0	$I_E = 100 \mu A$ H = 0	$I_C = 1.0 \text{ mA}$ H = 400 fc	$I_C = 1.0 \text{ mA}$ $R_L = 100 \Omega$			
	Min.	Max.	(nA) Max.	V_{CE} (Volts)	Volts, Min.	Volts, Min.	Volts, Max.		$\mu\text{sec, Typ.}$	
VTT9102H	6.0	—	100 (5)	100	5	30	4.0	0.55	6.0	$\pm 42^\circ$
VTT9103H	13.0	—	100 (5)	100	5	30	4.0	0.55	10.0	$\pm 42^\circ$

■ Refer to General Product Notes, page 2.