



Features

- 18V to 36V Input Voltage Range
- Programmable Output Voltage Range: 1.3V to 3.5V
- -40° to +85°C Ambient
- 1500 VDC Isolation
- 89% Efficiency
- On/Off Inhibit
- Differential Remote Sense
- N+1 Current Sharing
- Over-Current Protection
- Over-Temperature Protection
- Over-Voltage Protection
- Space-Saving Package
- Solderable Copper Case
- Safety Approvals:
 - UL 60950
 - CSA 22.2 950
 - VDE EN60950 Pending

Description

The PT4471 Excalibur™ DC/DC converter module combines state-of-the-art power conversion technology with un-paralleled flexibility. Incorporating high efficiency and ultra-fast transient response, these modules provide up to 30A of output current over the programmable voltage range of 1.3V to 3.5V. This represents a full 100W output at 3.3V.

The modules include a number of inbuilt features to facilitate system integration. These include a foldback output current limit, over-temperature protection, and an inhibit on/off control. A differential remote sense is also provided to compensate for voltage drop between the converter and load.

For applications requiring power supply redundancy, multiple PT4471 modules may be connected for operation in an 'N+1' configuration. Each PT4471 connected will share the load current with other active PT4471 modules.

Ordering Information

PT 4471□ = 1.3 to 3.5 Volts

PT Series Suffix (PT1234 x)

Case/Pin Configuration	Order Suffix	Package Code *
Vertical	N	(EKD)
Horizontal	A	(EKA)
SMD	C	(EKC)

* Previously known as package styles 1200, 1210, and 1215.

(Reference the applicable package code drawing for the dimensions and PC board layout)

Pin-Out Information

Pin	Function	Pin	Function
1	+V _{in}	14	-V _{out}
2	-V _{in}	15	-V _{out}
3	Inhibit	16	-V _{out}
4	Do not connect	17	-V _{out}
5	Do not connect	18	-V _{out}
6	Sync †	19	-V _{out}
7	(+)Remote Sense	20	(-)Remote Sense
8	+V _{out}	21	VID0
9	+V _{out}	22	VID1
10	+V _{out}	23	VID2
11	+V _{out}	24	VID3
12	+V _{out}	25	VID4
13	+V _{out}	26	Share †

† Pins 6 & 26 are used for N+1 configuration (see related application note). For stand-alone operation, leave open circuit.

• Shaded functions indicate those pins that are referenced to primary-side potential.

Standard Application

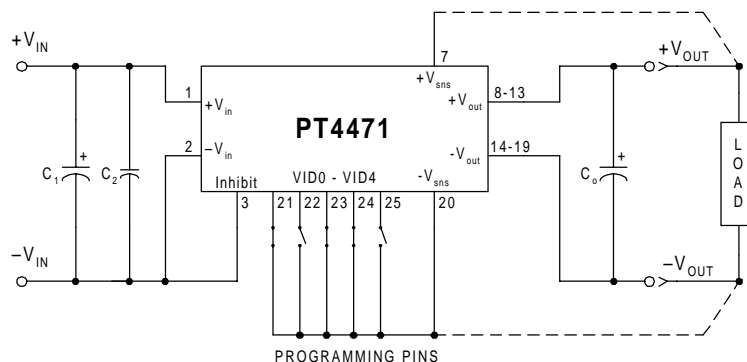

- C_o = Optional 330μF electrolytic capacitor
- C₁ = Optional 33μF, 50V electrolytic capacitor
- C₂ = Optional 1μF, 50V ceramic capacitor
- Programming pins, VID0-VID4, are shown configured for V_o = 3.3V
- For normal operation, pin 3 (Inhibit) must be connected to -V_{in}.
- For details on additional N+1 components consult the related application note.

Programming Information

VID3	VID2	VID1	VID0	VID4=1 Vout	VID4=0 Vout
1	1	1	1	2.0V	1.30V
1	1	1	0	2.1V	1.35V
1	1	0	1	2.2V	1.40V
1	1	0	0	2.3V	1.45V
1	0	1	1	2.4V	1.50V
1	0	1	0	2.5V	1.55V
1	0	0	1	2.6V	1.60V
1	0	0	0	2.7V	1.65V
0	1	1	1	2.8V	1.70V
0	1	1	0	2.9V	1.75V
0	1	0	1	3.0V	1.80V
0	1	0	0	3.1V	1.85V
0	0	1	1	3.2V	1.90V
0	0	1	0	3.3V	1.95V
0	0	0	1	3.4V	2.00V
0	0	0	0	3.5V	2.05V

Logic 0 = Connect to (-)Remote Sense, pin 20
Logic 1 = Open circuit (no pull-up resistors)
VID3 & VID4 must not be changed while unit is operating

PT4470 Series Comparison

#	Functionality	Output Voltage Program Range	Configuration for Current Sharing
PT 4471	Regulator	1.3V–3.5V	N+1 with other PT4471s
PT 4472	Regulator	1.3V–3.5V	With PT4495 boosters
PT 4495	PT4472 Booster	N/A	Used only with PT4472
PT 4473	Regulator	4.6V–5.7V	N+1 with other PT4473s
PT 4474	Regulator	4.6V–5.7V	With PT4494 boosters
PT 4494	PT4474 Booster	N/A	Used only with PT4474
PT 4475	Regulator	6.5V–17.5V	N+1 with other PT4475s
PT 4476	Regulator	6.5V–17.5V	With PT4493 boosters
PT 4493	PT4476 Booster	N/A	Used only with PT4476

This specification covers only the PT4471 regulator.

Specifications (Unless otherwise stated, $T_a = 25^\circ\text{C}$, $V_{in} = 24\text{V}$, $V_o = 3.3\text{V}$, $C_o = 0\mu\text{F}$, and $I_o = I_{o\text{max}}$)

Characteristic	Symbol	Conditions	PT4471			Units	
			Min	Typ	Max		
Output Current	I_o	Over V_{in} range	0	—	30	A	
Input Voltage Range	V_{in}	Over I_o Range	18	24	36	VDC	
Set Point Voltage Tolerance	$V_o \text{ tol}$		—	± 1	± 1.5	% V_o	
Temperature Variation	Reg_{temp}	$-40^\circ \leq T_{\text{case}} \leq +100^\circ\text{C}$, $I_o = 0$	—	± 0.5	—	% V_o	
Line Regulation	Reg_{line}	Over V_{in} range	—	± 0.1	± 1	% V_o	
Load Regulation	Reg_{load}	Over I_o range	—	± 0.2	± 1	% V_o	
Total Output Voltage Variation	$\Delta V_{o\text{tot}}$	Includes set-point, line, load, $-40^\circ \leq T_{\text{case}} \leq +100^\circ\text{C}$	—	± 2	± 3	% V_o	
Efficiency	η	$I_o = 15\text{A}$	$V_o = 3.3\text{V}$	—	89	—	%
			$V_o = 2.5\text{V}$	—	87	—	
			$V_o = 1.5\text{V}$	—	81	—	
V_o Ripple (pk-pk)	V_r	20MHz bandwidth	$V_o > 2\text{V}$	—	60	75	mV _{pp}
			$V_o \leq 2\text{V}$	—	45	55	
Transient Response	t_{tr} ΔV_{tr}	0.1A/ μs load step, 50% to 75% $I_{o\text{max}}$	—	N/A	—	—	μs % V_o
		V_o over/undershoot	—	1	—	—	
		1A/ μs load step, 50% to 100% $I_{o\text{max}}$	—	75	—	—	μs % V_o
		V_o over/undershoot	—	± 5	—	—	
Current Limit	I_{lim}	$V_{in} = 18\text{V}$, $\Delta V_o = -1\%$ foldback continuous limit	—	35	—	A	
Current Share Tolerance	$I_{\text{shr tol}}$	With other PT4471 modules in N+1	—	± 10	—	%	
Over-Voltage Protection	OVP	Shutdown and latch off	—	125	—	% V_o	
Switching Frequency	f_s	Over V_{in} range	270	300	350	kHz	
Under-Voltage Lockout	UVLO		—	17	—	V	
Inhibit (Pin 3) Input High Voltage Input Low Voltage Input Low Current	V_{IH} V_{IL} I_{IL}	Referenced to $-V_{in}$ (pin 2)	2.5	—	Open (1)	V	
			-0.5	—	+0.8		
			—	-0.2	—		mA
Standby Input Current	$I_{\text{in standby}}$	pins 3 & 2 connected	—	4	10	mA	
Internal Input Capacitance	C_{in}		—	3	—	μF	
External Output Capacitance	C_{out}	Between $+V_o$ and $-V_o$	0	—	10,000	μF	
Isolation Voltage Capacitance Resistance		Input-output/input-case	1500	—	—	V	
		Input to output	—	1100	—	pF	
		Input to output	10	—	—	M Ω	
Operating Temperature Range	T_c	Case temperature, over V_{in} range	-40	—	+115 (2)	$^\circ\text{C}$	
Over-Temperature Shutdown	OTP	Case temperature, auto reset	—	120	—	$^\circ\text{C}$	
Storage Temperature	T_s		-40	—	+125	$^\circ\text{C}$	
Reliability	MTBF	Per Bellcore TR-332 50% stress, $T_a = 40^\circ\text{C}$, ground benign	1.4	—	—	10 ⁶ Hrs	
Mechanical Shock	—	Per Mil-Std-883D, method 2002.3, 1mS, half-sine, mounted to a fixture	—	500	—	G's	
Mechanical Vibration	—	Mil-Std-883D, Method 2007.2 20-2000Hz, pcb mounted	—	20 (3)	—	G's	
Weight	—		—	90	—	grams	
Flammability	—	Materials meet UL 94V-0	—	—	—		

Notes: (1) The Inhibit (pin 3) has an internal pull-up, which if left open circuit allows the converter to operate when input power is applied. The open-circuit is limited to 6.5V. Refer to the application notes for interface considerations.

(2) See Safe Operating Area curves or contact the factory for the appropriate derating.

(3) The case pins on through-hole pin configuration (suffix A) must be soldered. For more information see the applicable package outline drawing.

100-W 30-A Programmable
Isolated DC/DC Converter

Performance Characteristics, $V_o = 3.3V$ (See Note A)

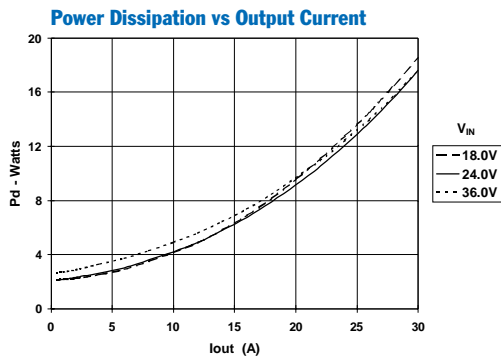
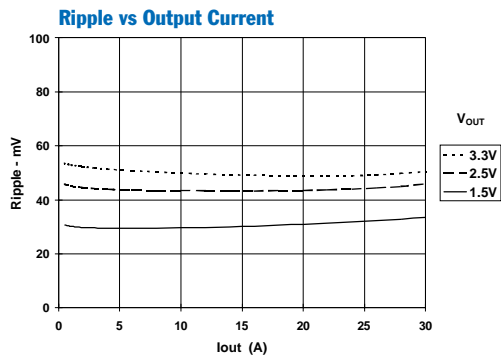
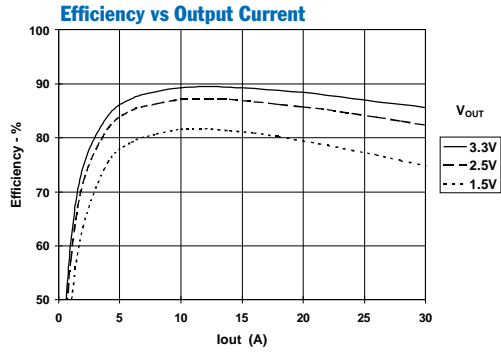

Safe Operating Area, $V_{IN} = 24V$ (See Note B)

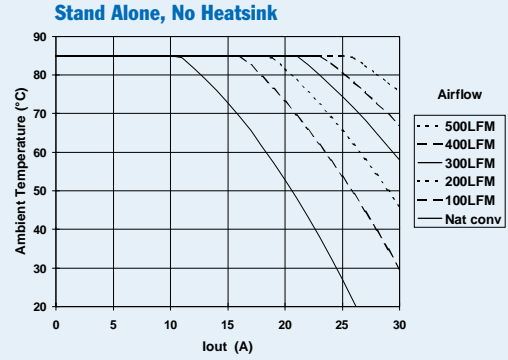

Note A: Characteristic data has been developed from actual products tested at 25°C. This data is considered typical data for the Converter.

Note B: SOA curves represent the conditions at which internal components are at or below the manufacturer's maximum operating temperatures

Configuring PT4471 DC/DC Converters for N+1 Operation

'N+1' vs OR'ing

The PT4471 DC/DC converter modules may be operated with other PT4471 modules in 'N+1' configurations. A simple OR'ing connection allows a number of converters to share the load current. An 'N+1' configuration adds redundancy by employing at least one more converter than is necessary to supply the load. This ensures that upon the loss of one converter, sufficient capacity remains to supply the load without interruption. As an example, a 45-A load configured for 'N+1' would require no less than three PT4471 converters. Two are needed to meet the load demand, plus one additional converter to ensure redundancy. Figure 1-1 shows the schematic for operating two PT4471 converters in an 'N+1' configuration for a 25-A load application.

Blocking Diodes

A true 'N+1' redundant system must also protect the output bus against fault current back-feeding a converter. Without a blocking diode, a converter will sink current as a result of a fault at its output, or due to the loss of its input source. The blocking diodes D_1 and D_2 in Figure 1-1, protect against reverse current flow under such conditions.

& D_2 in Figure 1-1), protect against reverse current flow under such conditions.

Notes

1. For 'N+1' redundancy, always use one more converter than is required to supply the load.
2. The VID pins for all converter modules must be independently set to the same voltage program code.
3. All converters connected for 'N+1' operation must be located on the same printed circuit board. A similar footprint and trace layout for each converter will facilitate current sharing.
4. A number of high-current rectifier diodes are available with a low forward voltage drop. They are specifically designed for OR'ing applications in 'N+1' systems. Eg. The 82CNQ030, and MBRB2515.
5. As a result of excess capacity and the losses in the blocking diodes, system efficiency is reduced.
6. The interconnection of pin 6 (Sync), and pin 26 (Share) between all modules are required for load current sharing and operation at a common frequency.

Figure 1-1; Connection Schematic for Operation in Parallel/N+1 Configuration

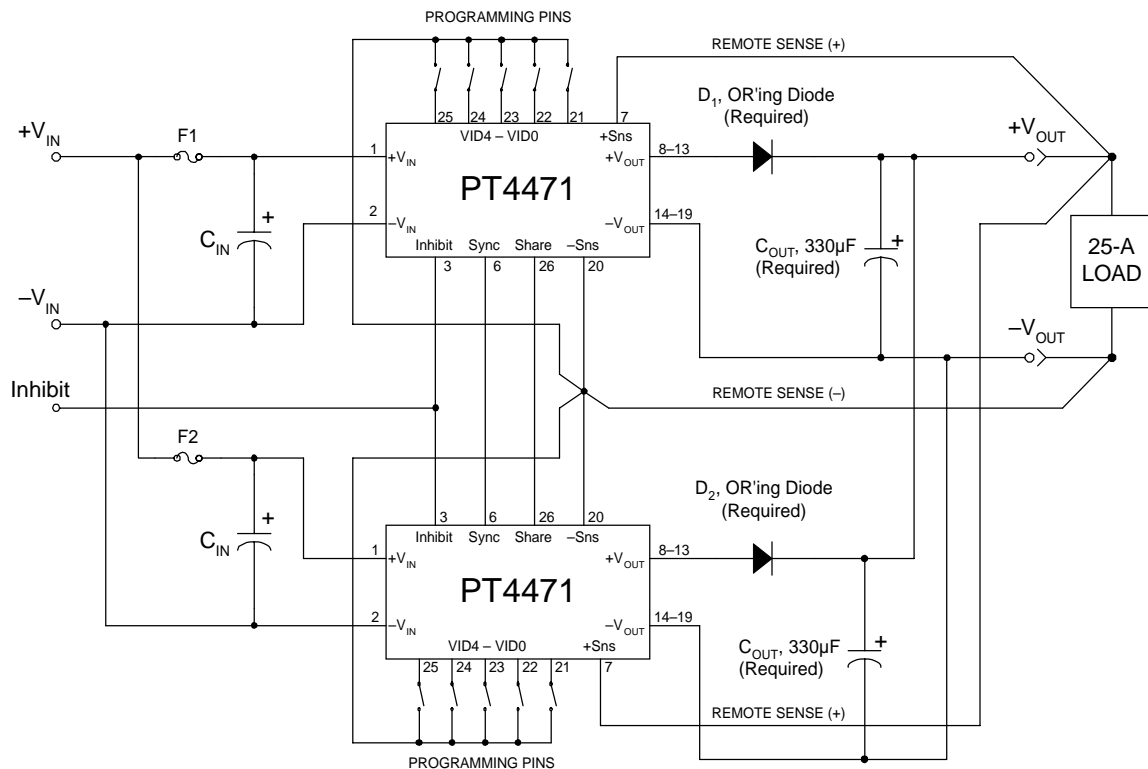

Operating Features of the PT4470 and PT4480 Series of Isolated DC/DC Converters

Under-Voltage Lockout

An Under-Voltage Lock-Out (UVLO) inhibits the operation of the converter until the input voltage is above the UVLO threshold (see the applicable data sheet specification). Below this voltage, the module's output is held off, irrespective of the state of the *Inhibit* control (pin 3). If the *Inhibit* control is connected to $-V_{in}$ (pin 2), the module will automatically power up when the input voltage rises above the UVLO threshold. The UVLO allows the module to produce a clean transition during both power-up and power-down, even when the input voltage is rising or falling slowly. It also reduces the high start-up current during normal power-up of the converter, and minimizes the current drain from the input source during low-input voltage conditions. The UVLO threshold includes about 2V of hysteresis. Once operational, the converter will conform to its operating specifications when the minimum specified input voltage is reached.

Over-Current Protection

To protect against load faults, the PT4470/80 series of DC/DC converters incorporate an output current limit. Once the load current drawn from the module reaches the current limit threshold, any attempt by the load to draw additional current will result in a significant drop in the module's regulated output voltage. The current limit circuitry incorporates a limited amount of foldback. This has the effect of slightly reducing the output current from the module when supplying an absolute short circuit. Upon removal of the load fault, the output voltage from the converter will automatically recover to its programmed regulation voltage.

Output Over-Voltage Protection

The PT4470/80 series of DC/DC converters incorporate circuitry that continually senses the output for an over-voltage (OV) condition. The OV threshold automatically tracks the VID output voltage program setting to a level 25% higher than that programmed at the control pins, VID0 through VID4. If the converter output voltage exceeds the OV threshold, the converter is immediately shut down and remains in a latched-off state. To resume normal operation the converter must be actively reset. This is accomplished by either cycling the status of the *Inhibit* control (pin 3) from "On" to "Off" and then back "On" again, or by momentarily removing the input power to the converter. For failsafe operation and redundancy, the OV protection uses circuitry that is independent of the converter's internal feedback loop.

Over-Temperature Protection

Over-temperature protection is provided by an internal temperature sensor, which closely monitors the temperature of the converter's metal case. If the case temperature exceeds the specified limit (see applicable data sheet), the converter will shut down. The converter will then automatically restart when the sensed temperature drops by about 10°C. When operated outside its recommended thermal derating envelope (see data sheet SOA curves), the converter will typically cycle on and off at intervals from a few seconds to one or two minutes. This is to ensure that the internal components are not permanently damaged from excessive thermal stress.

Primary-Secondary Isolation

Electrical isolation is provided between the input terminals (primary) and the output terminals (secondary). All converters are production tested to a primary-secondary withstand voltage of 1500VDC. This specification complies with UL60950 and EN60950 and the requirements for operational isolation. Operational isolation allows these converters to be configured for either a positive or negative input voltage source. The data sheet 'Pin-Out Information' uses shading to indicate which pins are associated with the primary. They include pins 1 through 5, inclusive.

Fuse Recommendations

If desired, an input fuse may be added to protect against the application of a reverse input voltage.

Thermal Considerations

Airflow may be necessary to ensure that the module can supply the desired load current in environments with elevated ambient temperatures. The required airflow rate may be determined from the Safe Operating Area (SOA) thermal derating chart (see converter specifications). The recommended direction for airflow is into the longest side of the module's metal case. See Figure 1.

Figure 1

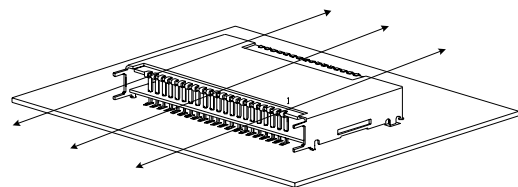

Recommended direction for airflow is into (perpendicular to) the longest side.

Using the Inhibit Function on the PT4470 & PT4480 Series of Isolated DC/DC Converters

The PT4470/44480 series of DC/DC converters incorporate an On/Off Inhibit function. This function may be used in applications that demand battery conservation, power-up/shutdown sequencing, and/or to coordinate power-up for active in-rush current control.

The On/Off feature is provided by the *Inhibit* control, pin 3. The *Inhibit* pin of the PT4470/4480 series of converters is an active low enable. The pin must be either connected, or actively pulled low, to $-V_{in}$ (pin 2) to enable the converter output (see standard application schematic). When pins 2 & 3 are connected, the converter provides a regulated output whenever a valid source voltage³ is applied between $+V_{in}$ (pin 1), and $-V_{in}$ (pin 2). If pin 3 is disconnected, or allowed to become high impedance, the regulator output will be disabled.⁵

Table 2-1 provides details of the interface requirements for the *Inhibit* pin. Figure 2-1 shows how a discrete MOSFET (Q_1)⁴, may be referenced to $-V_{in}$ and used to control the input.

Table 2-1 Inhibit Control Requirements

Parameter	Min	Max
Enable (V_{IH})	-0.5V	0.8V
Disable (V_{IL})	2.5V	(Open Circuit)

Notes:

1. The *Inhibit* control uses $-V_{in}$ (pin 2), on the primary side of the converter, as its ground reference. All voltages specified are with respect to $-V_{in}$.
2. The internal circuitry is simple pull-up resistor. The open-circuit voltage may be as high as 6.5Vdc.
3. These converters incorporate an “Under-Voltage Lockout” (UVLO) function. This function automatically disables the converter output until there is sufficient input voltage to produce a regulated output. Table 2 gives the applicable UVLO thresholds.

Table 2-2 UVLO Thresholds¹

Series	UVLO Threshold	V_{in} Range
PT4470	17.0V Typical	18 – 36V
PT4480	34.5V Typical	36 – 75V

4. The *Inhibit* input must be controlled with an open-collector (or open-drain) discrete transistor or MOSFET. Do not use a pull-up resistor.
5. When the converter output is disabled, the current drawn from the input supply is typically reduced to 4mA (10mA maximum).

6. Keep the on/off transition to less than 1ms. This prevents erratic operation of the ISR, whereby the output voltage may drift un-regulated between 0V and the rated output during power-up.

Figure 2-1

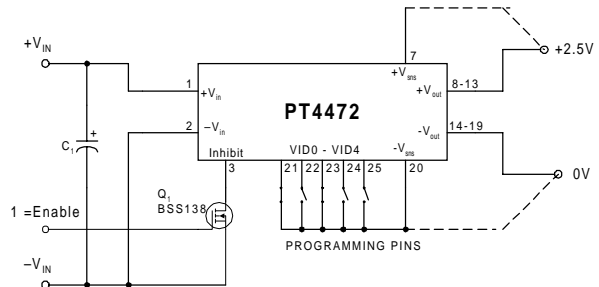

Turn-On Time: With input power applied, the converter typically produces a fully regulated output voltage within 25ms after applying a low-voltage signal to the *Inhibit* control pin. The actual turn-on time will vary with the input voltage, output load, and the total amount of capacitance connected to the output. Using the circuit of Figure 2-1, Figure 2-2 shows the typical output voltage and input current waveforms of a PT4472 after Q_1 is turned on. The turn on of Q_1 correlates to the fall in V_{inh} . The output voltage was set to 2.5V. The waveform was measured with a 48-Vdc input voltage, and 15-A load current.

Figure 2-2

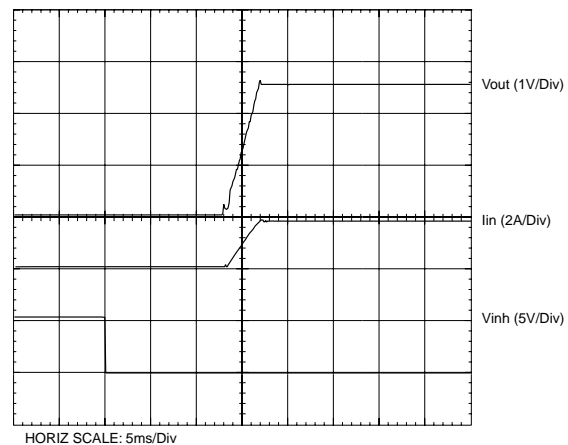

IMPORTANT NOTICE

Texas Instruments Incorporated and its subsidiaries (TI) reserve the right to make corrections, modifications, enhancements, improvements, and other changes to its products and services at any time and to discontinue any product or service without notice. Customers should obtain the latest relevant information before placing orders and should verify that such information is current and complete. All products are sold subject to TI's terms and conditions of sale supplied at the time of order acknowledgment.

TI warrants performance of its hardware products to the specifications applicable at the time of sale in accordance with TI's standard warranty. Testing and other quality control techniques are used to the extent TI deems necessary to support this warranty. Except where mandated by government requirements, testing of all parameters of each product is not necessarily performed.

TI assumes no liability for applications assistance or customer product design. Customers are responsible for their products and applications using TI components. To minimize the risks associated with customer products and applications, customers should provide adequate design and operating safeguards.

TI does not warrant or represent that any license, either express or implied, is granted under any TI patent right, copyright, mask work right, or other TI intellectual property right relating to any combination, machine, or process in which TI products or services are used. Information published by TI regarding third-party products or services does not constitute a license from TI to use such products or services or a warranty or endorsement thereof. Use of such information may require a license from a third party under the patents or other intellectual property of the third party, or a license from TI under the patents or other intellectual property of TI.

Reproduction of information in TI data books or data sheets is permissible only if reproduction is without alteration and is accompanied by all associated warranties, conditions, limitations, and notices. Reproduction of this information with alteration is an unfair and deceptive business practice. TI is not responsible or liable for such altered documentation.

Resale of TI products or services with statements different from or beyond the parameters stated by TI for that product or service voids all express and any implied warranties for the associated TI product or service and is an unfair and deceptive business practice. TI is not responsible or liable for any such statements.

Mailing Address:

Texas Instruments
Post Office Box 655303
Dallas, Texas 75265