

PRODUCT NO.
73725

PRODUCT NUMBER CODE

73725-X X X C X LF

HOUSING COLOR OPTION
0-WHITE
1-BLACK

SENSOR CONTACT OPTION
0-WITH SENSOR CONTACT
1-WITHOUT SENSOR CONTACT

SHIELD PLATING OPTION

- 1- 1.25µm MINIMUM NICKEL UNDERPLATE & 2.5µm MINIMUM BRIGHT TIN OVER ALL AREA. (HOLD DOWN STYLE "A")
- 2- 1.25µm MINIMUM NICKEL UNDERPLATED OVER ALL; 2.5 µm MINIMUM MATTE TIN PLATED ON HOLD DOWN AREA ONLY. (HOLD DOWN STYLE "B")
- 3- 1.25µm MINIMUM NICKEL UNDERPLATED OVER ALL; 2.5 µm MINIMUM MATTE TIN PLATED ON HOLD DOWN AREA ONLY. (HOLD DOWN STYLE "A")
- 4- 1.25µm MINIMUM NICKEL UNDERPLATED & 2.5µm MINIMUM BRIGHT TIN OVER ALL AREA. (HOLD DOWN STYLE "B")
- 5- 1.25µm MINIMUM NICKEL UNDERPLATED OVER ALL; 2.5µm MINIMUM MATTE TIN PLATED ON HOLD DOWN AREA ONLY (HOLD DOWN STYLE "C")
- 6- 1.25µm MINIMUM NICKEL ONLY. (HOLD DOWN STYLE "A")
- 7- 1.25µm MINIMUM NICKEL UNDERPLATED & 2.5 µm MINIMUM MATTE TIN PLATED OVER ALL. (HOLD DOWN STYLE "A")
- 8- 1.25µm MINIMUM NICKEL UNDERPLATED & 2.5 µm MINIMUM MATTE TIN PLATED ALL AREA. (HOLD DOWN STYLE "B")
- 9- 1.25µm MINIMUM NICKEL UNDERPLATED OVER ALL; 2.5 µm MINIMUM MATTE TIN PLATED ON HOLD DOWN AREA ONLY (HOLD DOWN STYLE "D")
- S- 1.25µm MINIMUM NICKEL ONLY. (HOLD DOWN STYLE "A"). HIGH PERFORMANCE MATERIAL FOR 12,000 DURABILITY CYCLES
- A- 1.25µm MINIMUM NICKEL PLATED OVER ALL 2.5 µm MINIMUM MATTE TIN PLATED ON HOLD DOWN AREA ONLY (HOLD DOWN STYLE "F")
- B- 1.25µm MINIMUM NICKEL PLATED OVER ALL 2.5 µm MINIMUM MATTE TIN PLATED ON HOLD DOWN AREA ONLY (HOLD DOWN STYLE "F")

TERMINAL OPTION

50u" NI UNDERPLATE; 30u" GXT CONTACT AREA, 100u" TIN TAIL AREA;

- 0- DIM "A": 2.29 (TERMINAL TAIL LENGTH);
- 1- DIM "A": 3.71 (TERMINAL TAIL LENGTH);
- 2- DIM "A": 3.00 (TERMINAL TAIL LENGTH);

NOTES:

1. MATERIAL:
CONTACTS: COPPER ALLOY
SHIELD: COPPER ALLOY
HOUSING: UL 94V-0 THERMOPLASTIC, COLOR: SEE PRODUCT CODE
2. PLATING:
CONTACTS: GOLD FLASH OVER PALLADIUM NICKEL (0.76µm MINIMUM) IN CONTACT AREA; 2.5 µm TIN MINIMUM IN SOLDER TAIL AREA.
1.27 µm MINIMUM NICKEL UNDERPLATE OVER ALL SURFACES.
SHIELD: SEE PRODUCT NUMBER CODE.
(THE PLATING MEASURE POINT ON THE SHIELD HOLD DOWN AREA ONLY).
3. DATUMS & BASIC DIMENSIONS TO BE DETERMINED BY CUSTOMER
4. RECOMMENDED PCB BOARD THICKNESS IS 1.00 ~ 1.60mm EXCEPT 73725-1191BLF; 73725-1191BLF CAN BE USED FOR THE PCB BOARD THICKNESS 2.30 ~ 2.65mm.
5. MAXIMUM PANEL THICKNESS TO BE 2.67mm IF MOUNTED BEHIND PANEL
6. METAL SHELL SLIVER 0.20 MAX.
7. NI PLATING DOES NOT COMPLY WITH THE USB STANDARDS (TO BE CONTINUED)

LEAD FREE OPTION
SEE NOTE 9

PACKAGING OPTION
B - TUBE
R - TAPE&REEL

SPECIAL CODE FOR CISCO

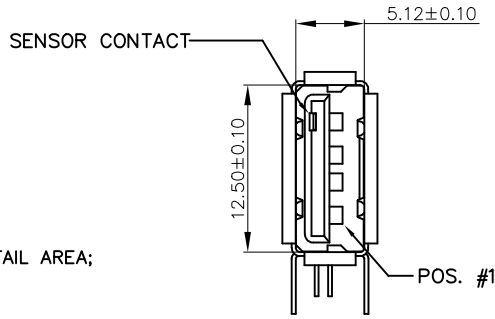
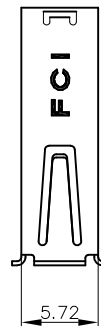

WITH SENSOR CONTACT

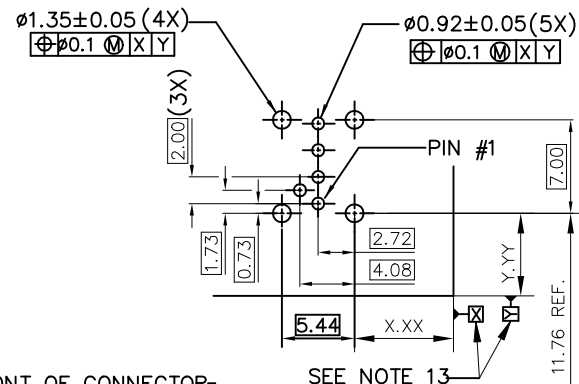

FRONT OF CONNECTOR

PC BOARD MOUNTING DIMENSIONS FOR 5 PIN

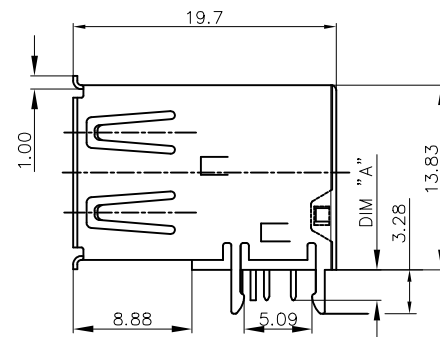

FOR 73725-X0X0B
HOLD DOWN STYLE "A"

Amphenol FCI

© 2016 AFCI

mat'l. code		surface ¹²³ tolerance		projection		product family	
		ISO 1302 ✓ ISO 406 ISO 1101		1101		HPL 511 USB 2.0	
ltr	ecn no	dr	date	tolerances unless otherwise specified		title	
AJ	ELX-N-27708	LZ	2017/08/15	angles	.0±.30	USB UP-RIGHT RECEIPT	
AK	ELX-N-34768	YY	2019/09/19	linear	.00±.20		
AL	ELX-N-39429	YY	2020/12/04	0°±2'	.000±.10	scale 1:1	
AL1	-	TY	2022/02/25	dr	PAMP	5/20/97	dwg no
				eng	R Y LIU	5/20/97	sheet 1 of 4
AG	ELX-N-21594	LQ	08/04/2015	chr	R Y LIU	5/20/97	size
AH	ELX-N-21919	LQ	08/04/2015	app	JENN TSAO	5/20/97	A3
sheet		revision		Amphenol FCI		type Product Customer Drawing	
index		sheet					

PRODUCT NO.
73725

(CONTINUED)

8. P/N'S WITH SUFFIX "LF" ARE LEAD FREE P/N'S
9. FOR LEAD FREE P/N, THE PRODUCT MEET EUROPEAN UNION DIRECTIVES AND OTHER COUNTRY REGULATION AS DESCRIBED IN GS-22-008
10. FOR THE PRODUCTS WITH THE METAL SHELL PLATING NICKEL AND MATTE SN CAN WITHSTAND EXPOSURE TO 260°C PEAK TEMPERATURE FOR 40 SECONDS IN A CONVECTION, INFRA-RED OR VAPOR PHASE REFLOW PROCESS; FOR THE PRODUCTS WITH METAL SHELL PLATING BRIGHT SN OR SEMI-BRIGHT SN CAN'T WITHSTAND REFLOW AND JUST CAN WITHSTAND EXPOSURE TO 260°C PEAK TEMPERATURE FOR 10 SECONDS IN WAVE SOLDERING PROCESS.
11. FOR ALL LEAD FREE P/N'S, WITH SUFFIX LF.
12. THE PRODUCT CAN BE USED FOR PIP PROCESS
13. DATUM OF CUSTOMER'S PCB LAYOUT.
14. TID NUMBER: 63000197.

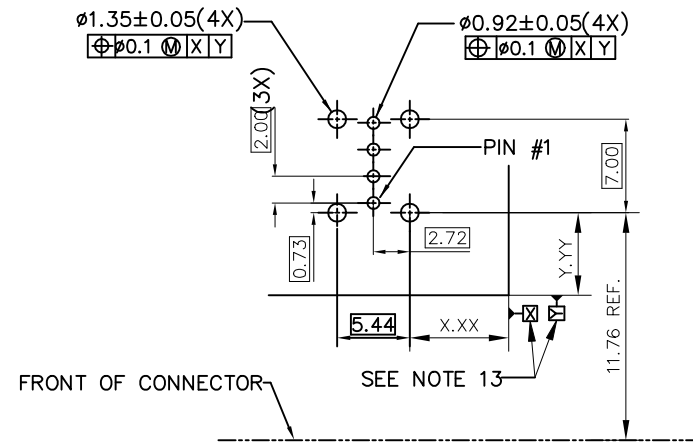
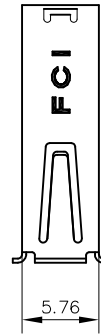

PC BOARD MOUNTING DIMENSIONS FOR 4 PIN

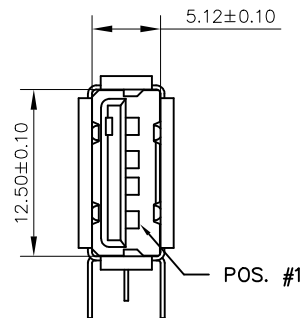
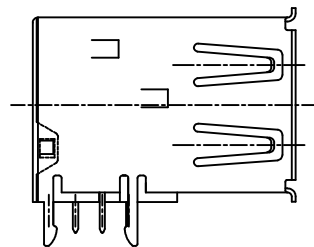

WITHOUT SENSOR CONTACT

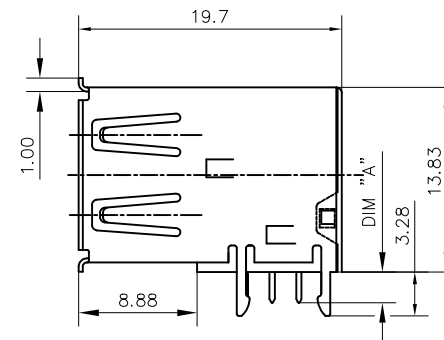

FOR 73725-X1X0B
HOLD DOWN STYLE "A"

Amphenol FCI

© 2016 AFCI

mat'l. code		surface ¹²³ tolerance		projection		product family	
		ISO 1302 ✓ ISO 406 ISO 1101				HPL 511 USB 2.0	
ltr		ecn no		dr		date	
AL1							
tolerances unless otherwise specified		angles		linear		title	
		0°±2'		.0±.30 .00±.20 .000±.10		mm	
				scale 1:1		USB UP-RIGHT RECEPT	
dr		PAMP		5/20/97		dwg no	
engr		R Y LIU		5/20/97		sheet 2 of 4	
chr		R Y LIU		5/20/97		73725	
app'd		JENN TSAO		5/20/97		A3	
type		Product Customer Drawing					
sheet index		revision sheet					

PRODUCT NO.
73725

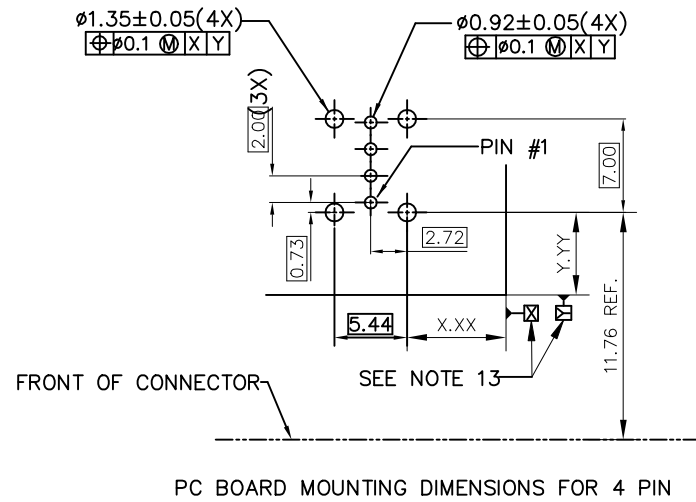

PC BOARD MOUNTING DIMENSIONS FOR 4 PIN

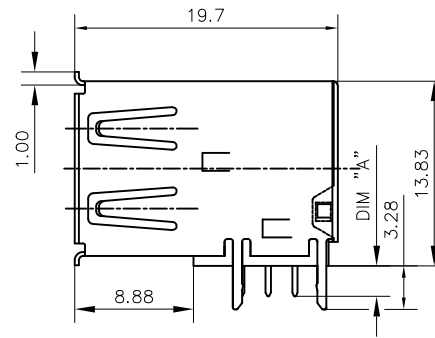

WITHOUT SENSOR CONTACT
FOR 73725-X1X0B
HOLD DOWN STYLE "B"

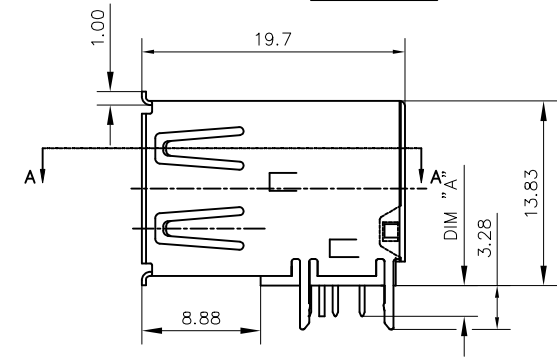

WITH SENSOR CONTACT
FOR 73725-X0X0B
HOLD DOWN STYLE "B"

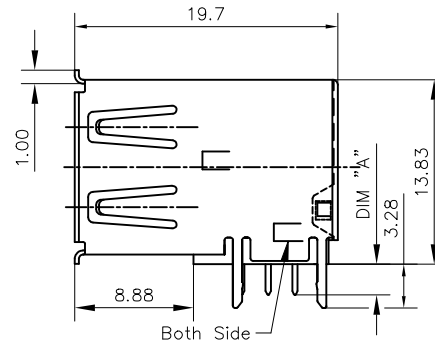

WITHOUT SENSOR CONTACT
FOR 73725-XXA0XLF
73725-XXB0XLF ONLY
HOLD DOWN STYLE "F"

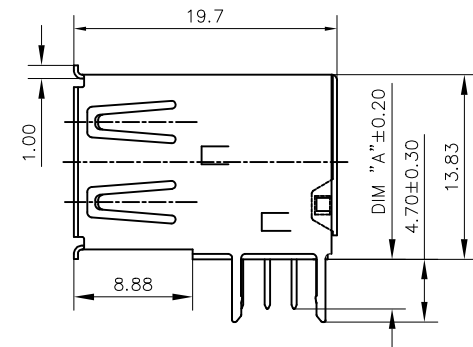

WITHOUT SENSOR CONTACT
FOR 73725-X191XLF
HOLD DOWN STYLE "D"

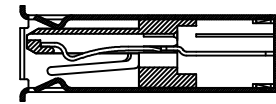

SECTION A-A

Amphenol
FCI

© 2016 AFCI

mat'l. code		surface ¹²³ tolerance		projection		product family	
		ISO 1302 ✓ ISO 406 ISO 1101		1101		HPL 511 USB 2.0	
ltr		ecn no		dr		date	
AL1							
angles		linear		mm		title	
0°±2'		.00±.20		scale 1:1		USB UP-RIGHT RECEIPT	
		.000±.10				dwg no	
dr		PAMP		5/20/97		sheet 3 of 4	
engr		R Y LIU		5/20/97		size	
chr		R Y LIU		5/20/97		A3	
appd		JENN TSAO		5/20/97		type	
						Product Customer Drawing	
sheet index		revision sheet					

