

ASMT-QYBF-NJK0E

Super 0.5 W Warm White Power PLCC-4
Surface Mount LED Indicator



Data Sheet



Description

The Super 0.5 W Warm White Power PLCC-4 SMT LED is using InGaN chip technology. The package can be driven at high current due to its superior package design. The product is able to dissipate the heat more efficiently compared to the Power PLCC-4 SMT LEDs. These LEDs produce higher light output with better flux performance compared to the Power PLCC-4 SMT LED.

The Super 0.5 W Warm White Power PLCC-4 SMT LEDs are designed for higher reliability, better performance, and operate under a wide range of environmental conditions.

To facilitate easy pick and place assembly, the LEDs are packed in EIA-compliant tape and reel. Every reel is shipped in single intensity and color bin, to provide close uniformity.

Features

- Industry Standard PLCC 4 platform (3.2 x 2.8 x 1.9 mm)
- High reliability package with enhanced silicone resin encapsulation
- High brightness with optimum flux performance using InGaN chip technologies
- Available in Warm White
- Available in 8 mm carrier tape & 7 inch reel
- Wide viewing angle at 120 degree
- JEDEC MSL 2

Applications

- Interior automotive
 - a. Instrument panel backlighting
 - b. Central console backlighting
 - c. Navigation and audio system backlighting
 - d. Dome/Map lighting
 - e. Push button backlighting
 - f. Puddle lamp
 - g. Glove compartment illumination
- Electronic signs and signals
 - a. Decorative lighting
- Office automation, home appliances, industrial equipment
 - a. Panel/button backlighting
 - b. Display backlighting
- Others
Illuminations
Advertising board Back lighting

CAUTION: LEDs are Class 2 ESD sensitive. Please observe appropriate precautions during handling and processing.

Package Drawing

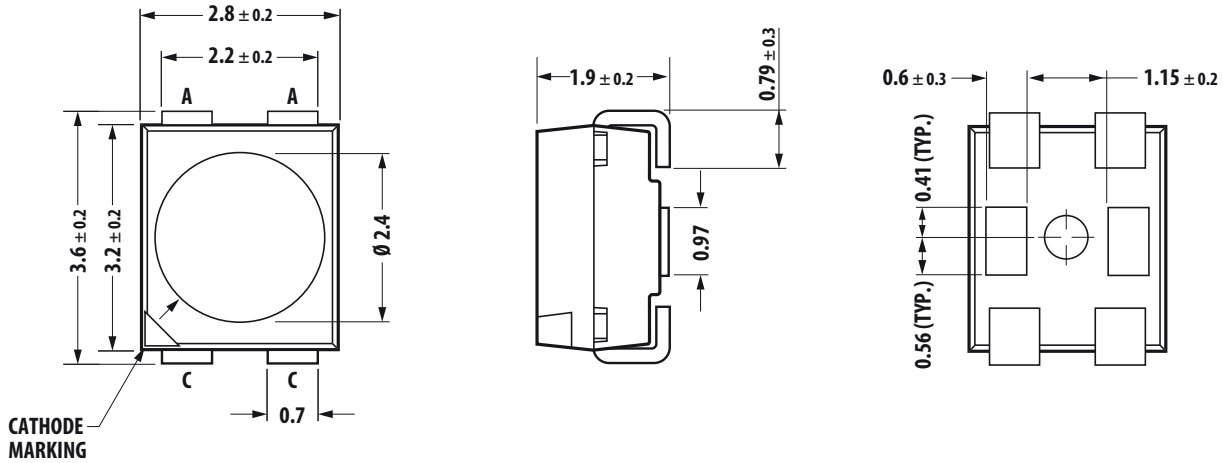

- Notes:
1. All dimensions in millimeters.
 2. Terminal finish: ag plating.
 3. Encapsulation material: silicone resin.

Device Selection Guide ($T_j = 25^\circ\text{C}$)

Color	Part Number	Luminous Flux, $\theta_V^{[1]}$ (lm)			Test Current (mA)	Dice Technology
		Min	Typ	Max		
Warm White	ASMT-QYBF-NJK0E	33	39	56	150	InGaN

- Notes:
1. θ_V is the total luminous flux output as measured with an integrating sphere at mono pulse conditions.
 2. Tolerance $\pm 12\%$.

Part Numbering System

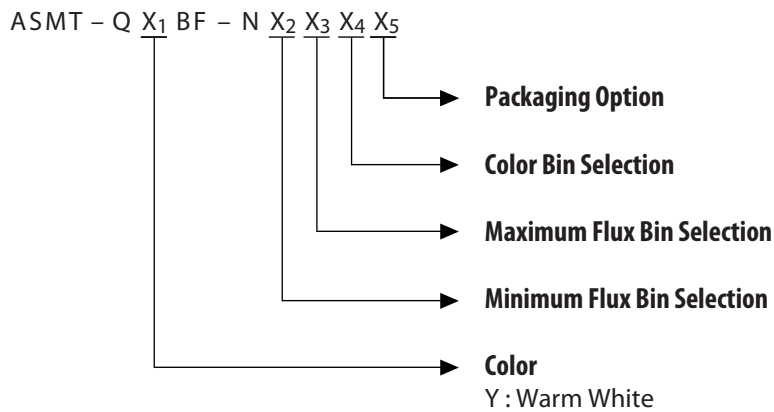

Absolute Maximum Ratings ($T_A = 25\text{ }^\circ\text{C}$)

Parameter	Rating	Unit
DC Forward Current	150	mA
Peak Forward Current ^[1]	300	mA
Power Dissipation	570	mW
Reverse Voltage	Not Recommended	V
Junction Temperature	125	$^\circ\text{C}$
Operating Temperature	-40 to +120	$^\circ\text{C}$
Storage Temperature	-40 to +120	$^\circ\text{C}$

Note:

1. Duty Factor = 10%, Frequency = 1 kHz

Optical / Electrical Characteristics ($T_J = 25\text{ }^\circ\text{C}$, $I_F = 150\text{ mA}$)

CCT (K)	Viewing Angle	Luminous Efficiency	Forward Voltage	Thermal Resistance	
	$2\theta_{1/2}$ ^[1] (Degree)	η_e (lm/W)	V_F (Volt)	Max	$R_{\theta_{J-P}}$ ($^\circ\text{C/W}$)
	Typ	Typ	Typ		
2500 ~ 4800	120	78	3.30	3.50	50

Note:

1. $\theta_{1/2}$ is the off-axis angle where the luminous intensity is $1/2$ the peak intensity.

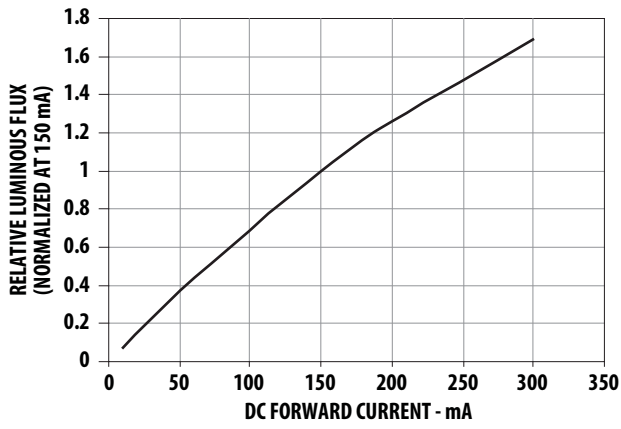

Figure 1. Relative luminous flux vs Forward current

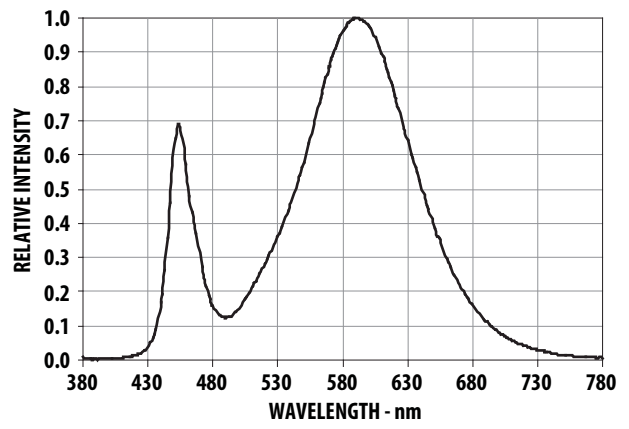

Figure 2. Color spectrum

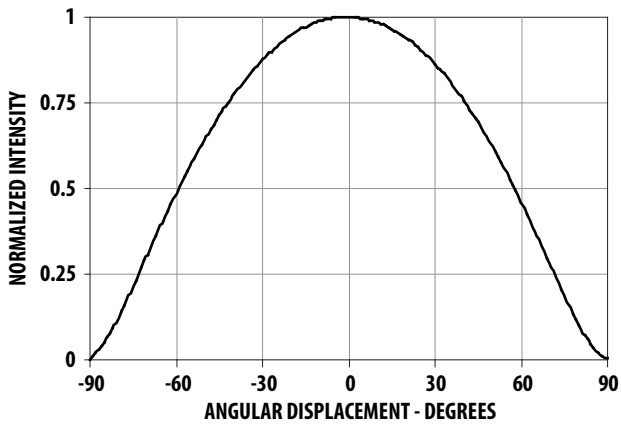

Figure 3. Radiation Pattern

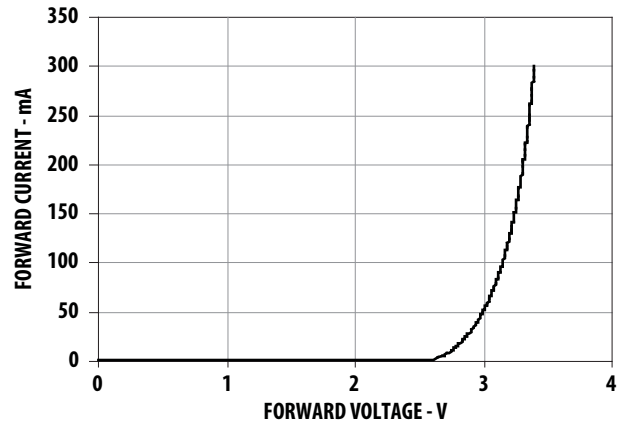

Figure 4. Forward current vs Forward voltage

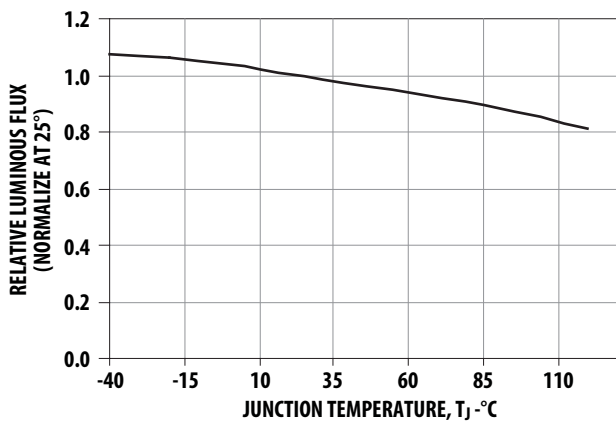

Figure 5. Relative flux vs Temperature

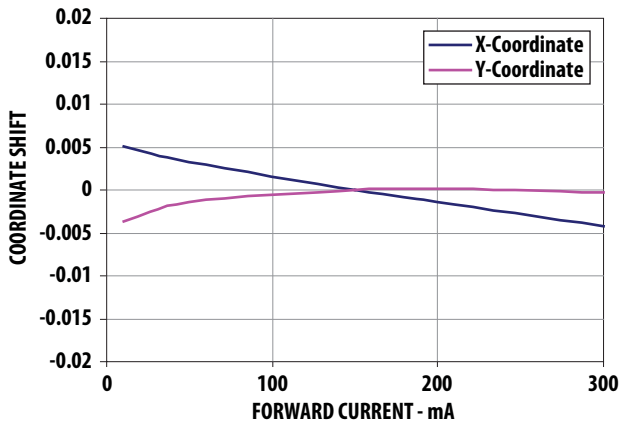

Figure 6. Chromaticity shift vs Forward current

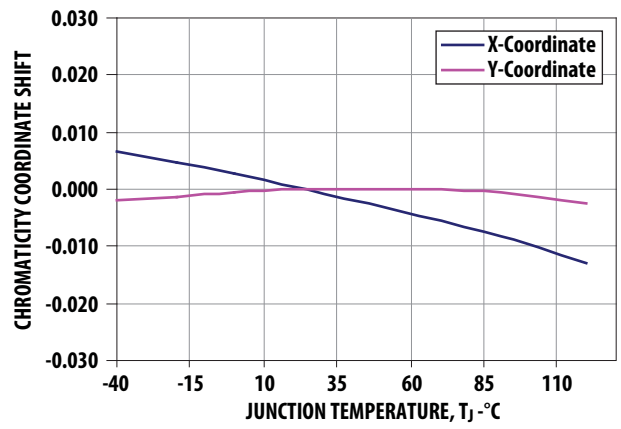

Figure 7. Chromaticity shift vs Temperature

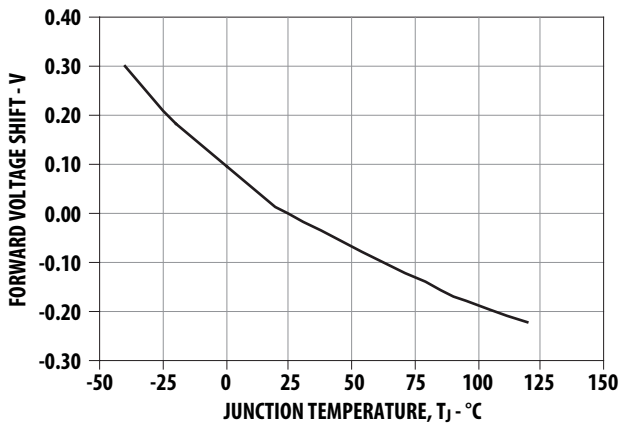

Figure 8. Relative forward voltage shift vs Temperature

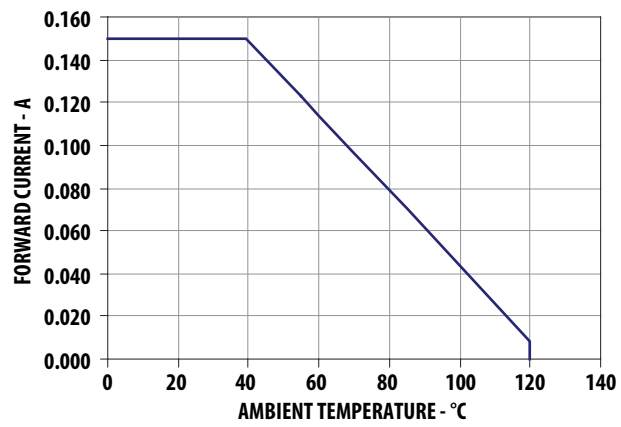

Figure 9. Maximum forward current vs. Ambient temperature. Derated base on $T_{j\max} 125^\circ\text{C}$, $R\theta_{ja} 150^\circ\text{C/W}$.

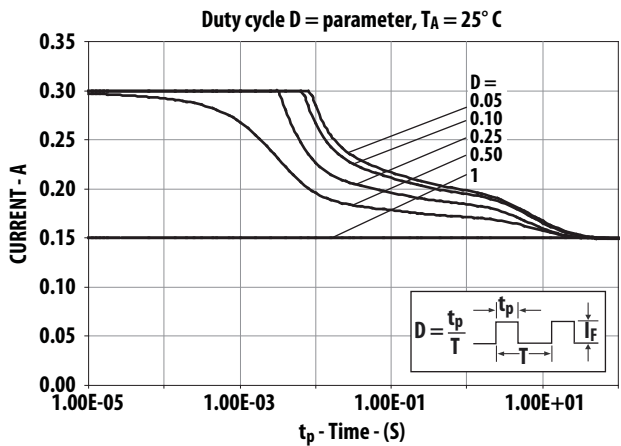

Figure 10. Maximum pulse current vs Ambient temperature $T_A = 25^\circ\text{C}$

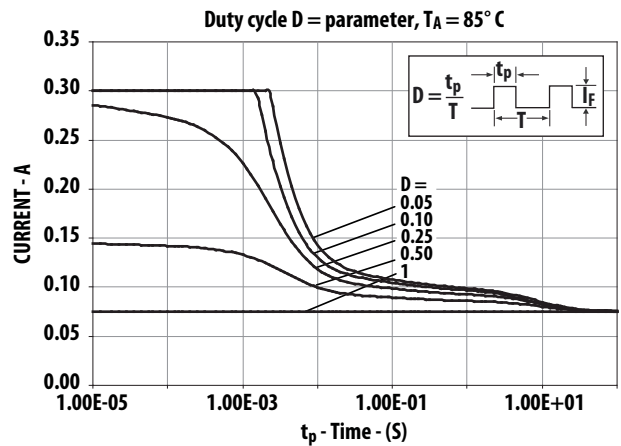
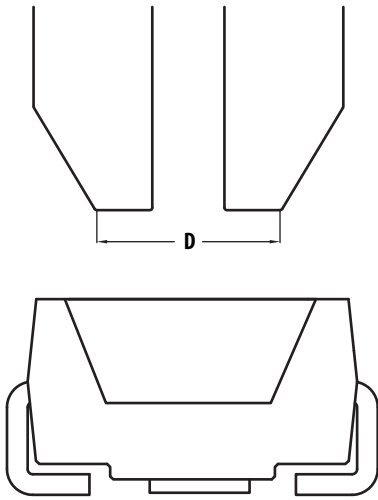
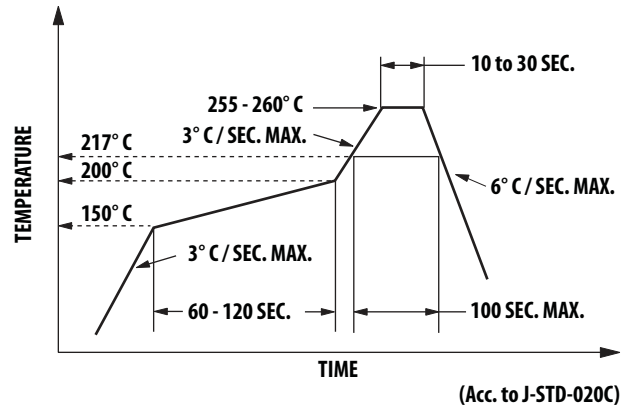

Figure 11. Maximum pulse current vs Ambient temperature $T_A = 85^\circ\text{C}$



Note: Diameter "D" should be smaller than 2.2 mm SMT LED Indicator Components

Figure 12. Recommended pick and place nozzle size



Note: For detail information on reflow soldering of Avago surface mount LEDs, do refer to Avago Application Note AN 1060 Surface Mounting

Figure 13. Recommended Pb free reflow soldering profile

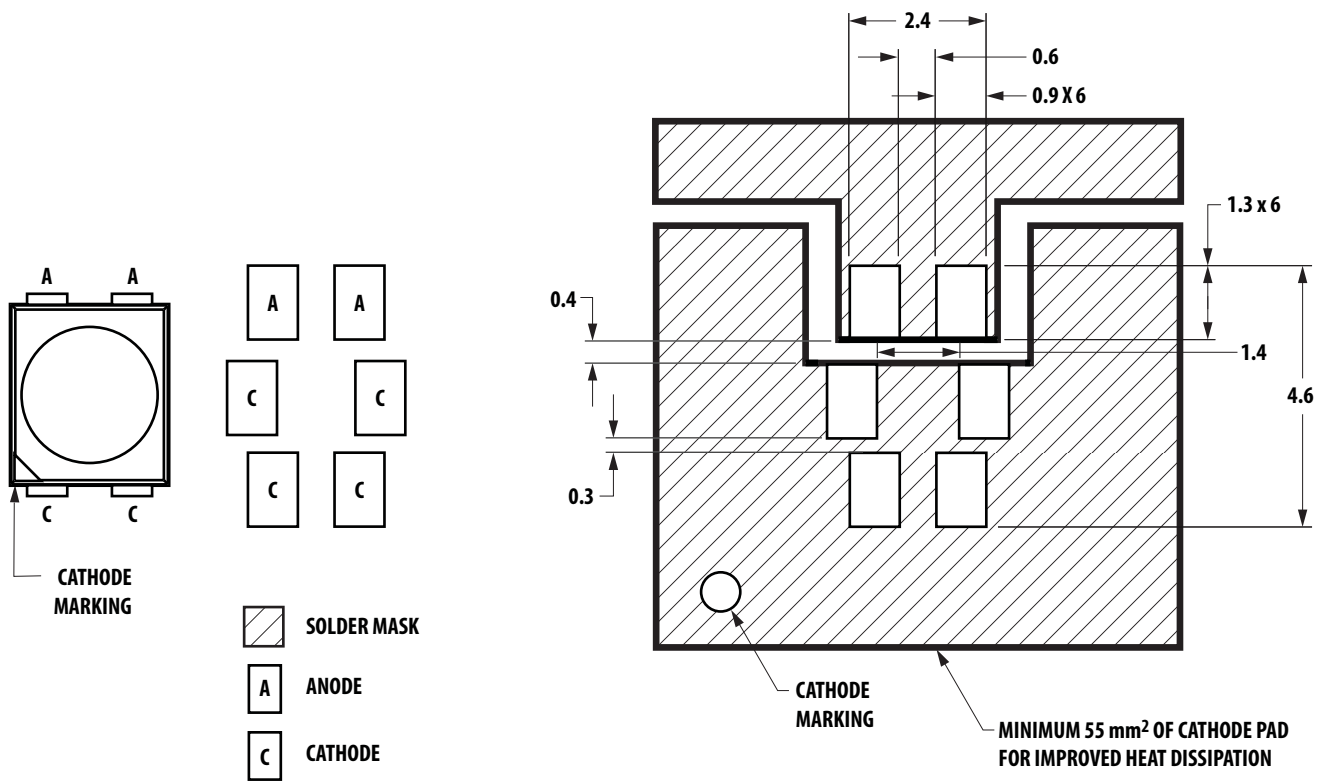

Figure 14. Recommended soldering pad pattern

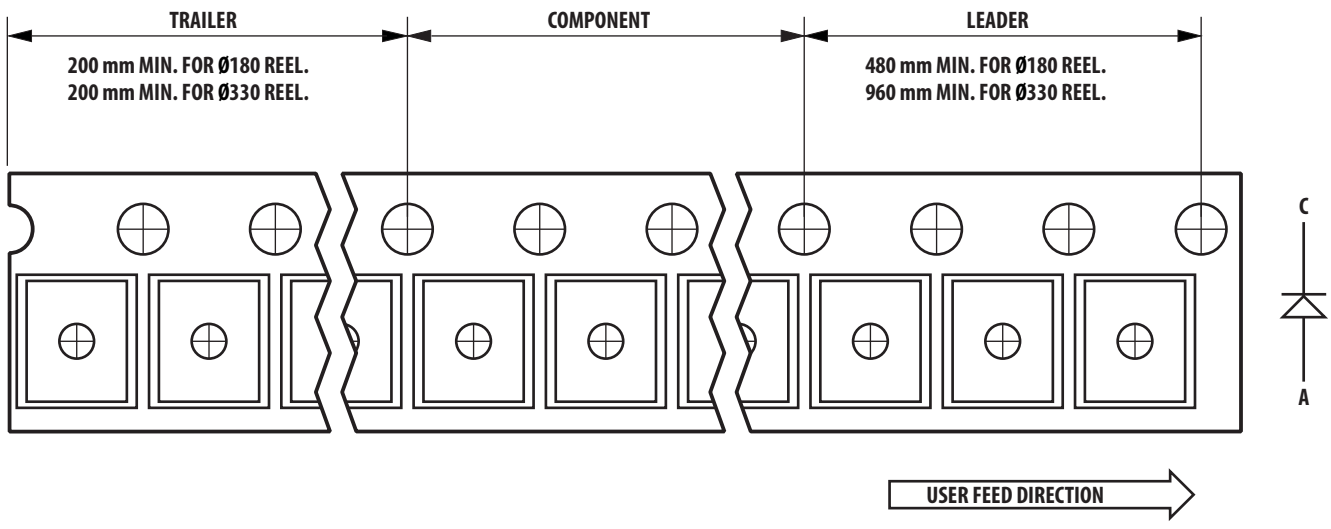

Figure 15. Tape leader and trailer dimensions

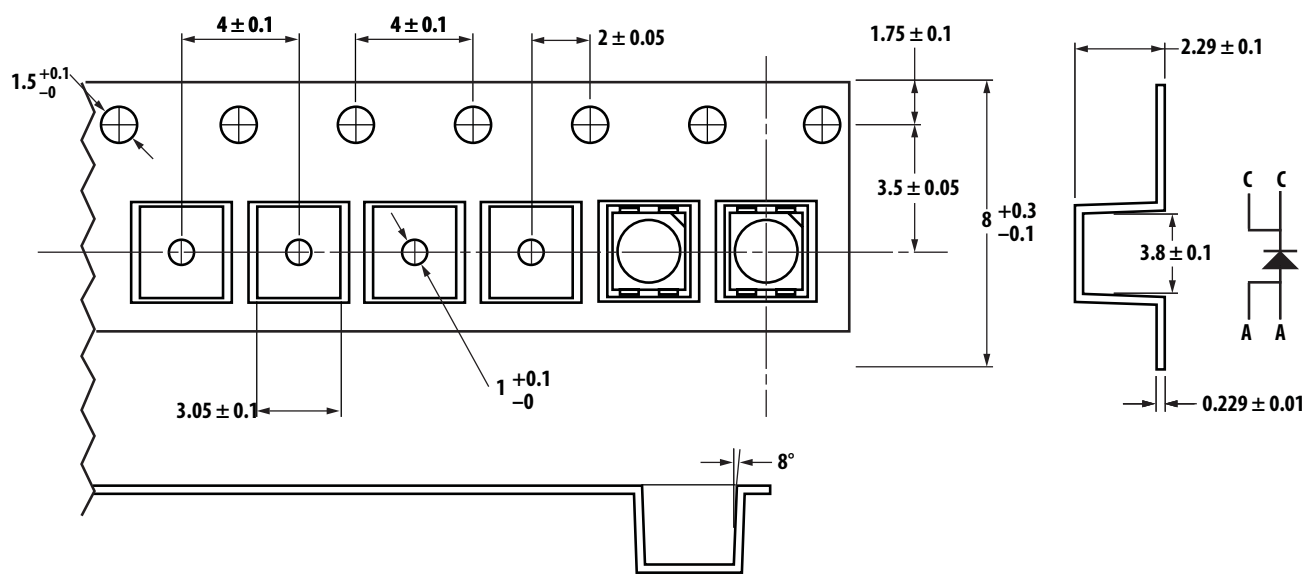

Figure 16. Tape dimensions

Handling Precaution

The encapsulation material of the product is made of silicone for better reliability of the product. As silicone is a soft material, please do not press on the silicone or poke a sharp object onto the silicone. These might damage the product and cause premature failure. During assembly or handling, the unit should be held on the body only.

Moisture Sensitivity

This product is qualified as Moisture Sensitive Level 2 per Jedec J-STD-020. Precautions when handling this moisture sensitive product is important to ensure the reliability of the product.

A. Storage before use

- Unopen moisture barrier bag (MBB) can be stored at <40°C/90%RH for 12 months. If the actual shelf life has exceeded 12 months and the HIC indicates that baking is not required, then it is safe to reflow the LEDs per the original MSL rating.
- It is not recommended to open the MBB prior to assembly (e.g. for IQC).

B. Control after opening the MBB

- The humidity indicator card (HIC) shall be read immediately upon opening of MBB.
- The LEDs must be kept at <30°C/60%RH at all time and all high temperature related process including soldering, curing or rework need to be completed within 1 year.

C. Control for unfinished reel

- For any unused LEDs, they need to be stored in sealed MBB with desiccant or desiccator at <5%RH.

D. Control of assembled boards

- If the PCB soldered with the LEDs is to be subjected to other high temperature processes, the PCB need to be stored in sealed MBB with desiccant or desiccator at <5%RH to ensure no LEDs have exceeded their floor life of 1 year.

E. Baking is required if:

- "60%" HIC indicator is NOT blue.
- The LEDs are exposed to condition of >30°C/60% RH at any time.
- The LEDs floor life exceeded 1 year.

Recommended baking condition: 60±5°C for 20 hours.

Device Color (X₁)

Y	Warm White
---	------------

Flux Bin Select (X₂X₃)

Individual reel will contain parts from one bin only

X ₂	Min Flux Bin
----------------	--------------

X ₃	Max Flux Bin
----------------	--------------

Flux Bin

Bin ID	Min (lm)	Max (lm)
B	5.50	7.00
C	7.00	9.00
D	9.00	11.50
E	11.50	15.00
F	15.00	19.50
G	19.50	25.50
H	25.50	33.00
J	33.00	43.00
K	43.00	56.00
L	56.00	73.00

Tolerance ± 12%

Color Bin Select (X₄)

Individual reel will contain parts from one sub bin only.

X ₄	
0	Full Distribution
A	H, J and K only
B	H, J, K, L and M only
C	L and M only
D	L, M, N and P only
E	N and P only
F	N, P, Q and R only
G	Q and R only
Z	Special Color Bin

Color Bin

Bin ID	Sub Bin ID	Chromaticity Coordinates				
H	H3	x	0.348	0.360	0.364	0.350
		y	0.332	0.341	0.358	0.348
	H4	x	0.350	0.364	0.367	0.352
		y	0.348	0.358	0.376	0.365
	H5	x	0.352	0.367	0.371	0.354
		y	0.365	0.376	0.392	0.381
J	J3	x	0.360	0.373	0.378	0.364
		y	0.341	0.350	0.368	0.358
	J4	x	0.364	0.378	0.383	0.367
		y	0.358	0.368	0.386	0.376
	J5	x	0.367	0.383	0.388	0.371
		y	0.376	0.386	0.403	0.392
K	K3	x	0.373	0.387	0.393	0.378
		y	0.350	0.358	0.376	0.368
	K4	x	0.378	0.393	0.399	0.383
		y	0.368	0.376	0.395	0.386
	K5	x	0.383	0.399	0.405	0.388
		y	0.386	0.395	0.412	0.403
L	L3	x	0.387	0.400	0.407	0.393
		y	0.358	0.366	0.384	0.376
	L4	x	0.393	0.407	0.414	0.399
		y	0.376	0.384	0.402	0.395
	L5	x	0.399	0.414	0.421	0.405
		y	0.395	0.402	0.420	0.412
M	M3	x	0.400	0.413	0.421	0.407
		y	0.366	0.372	0.390	0.384
	M4	x	0.407	0.421	0.429	0.414
		y	0.384	0.390	0.409	0.402
	M5	x	0.414	0.429	0.436	0.421
		y	0.402	0.409	0.426	0.420
N	N3	x	0.413	0.425	0.434	0.421
		y	0.372	0.378	0.396	0.390
	N4	x	0.421	0.434	0.443	0.429
		y	0.390	0.396	0.414	0.409
	N5	x	0.429	0.443	0.451	0.436
		y	0.409	0.414	0.430	0.426
P	P3	x	0.425	0.438	0.447	0.434
		y	0.378	0.382	0.400	0.396
	P4	x	0.434	0.447	0.456	0.443
		y	0.396	0.400	0.417	0.414
	P5	x	0.443	0.456	0.465	0.451
		y	0.414	0.417	0.434	0.430
Q	Q3	x	0.438	0.450	0.460	0.447
		y	0.382	0.386	0.403	0.400
	Q4	x	0.447	0.460	0.470	0.456
		y	0.400	0.403	0.420	0.417
	Q5	x	0.456	0.470	0.479	0.465
		y	0.417	0.420	0.436	0.434
R	R3	x	0.450	0.462	0.472	0.460
		y	0.386	0.389	0.405	0.403
	R4	x	0.460	0.472	0.482	0.470
		y	0.403	0.405	0.422	0.420
	R5	x	0.470	0.482	0.491	0.479
		y	0.420	0.422	0.437	0.436

Tolerance ± 0.01

Color Coordinates Chart

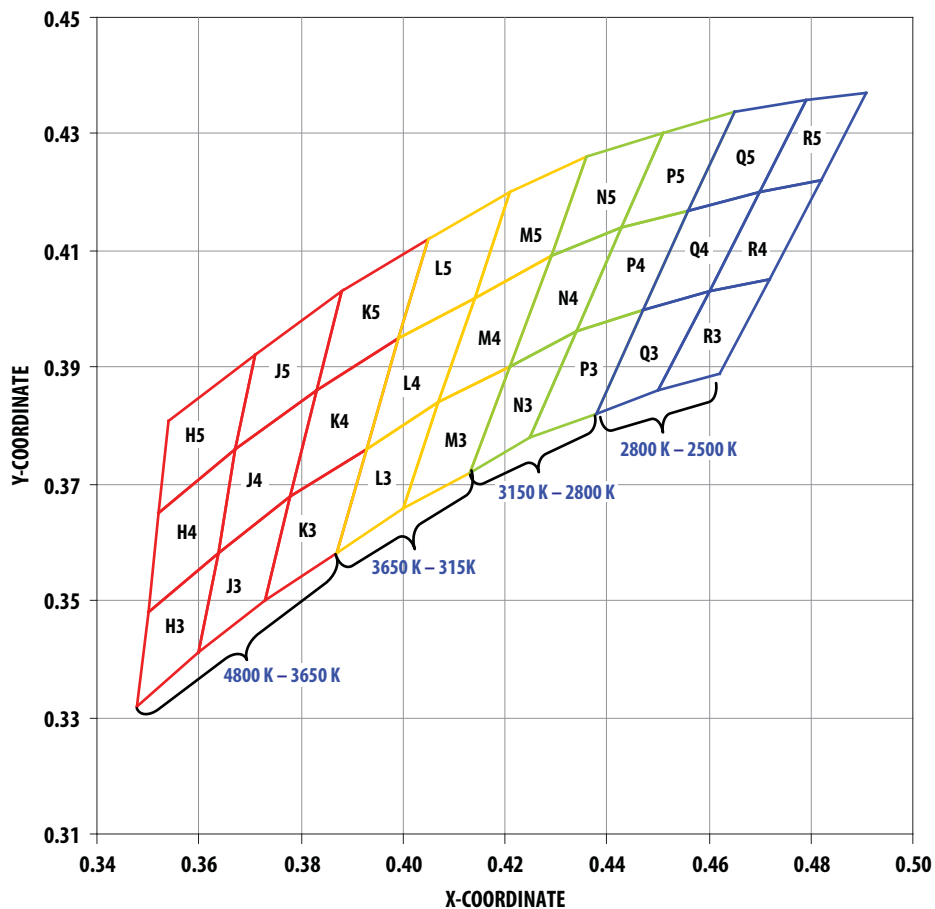

Vf Bin

Bin	Min (V)	Max (V)
S4	2.90	3.20
S5	3.20	3.50

Tolerance ± 0.1 V

Packaging Option (X₅)

Option	Test Current	Package Type	Reel Size
E	150 mA	Top Mount	7 inch

DISCLAIMER: Avago's products and software are not specifically designed, manufactured or authorized for sale as parts, components or assemblies for the planning, construction, maintenance or direct operation of a nuclear facility or for use in medical devices or applications. Customer is solely responsible, and waives all rights to make claims against avago or its suppliers, for all loss, damage, expense or liability in connection with such use.

For product information and a complete list of distributors, please go to our web site: www.avagotech.com

Avago, Avago Technologies, and the A logo are trademarks of Avago Technologies in the United States and other countries. Data subject to change. Copyright © 2005-2012 Avago Technologies. All rights reserved.
AV02-3152EN - May 30, 2012

AVAGO
TECHNOLOGIES