

STRAIGHT BULKHEAD JACK PANEL SEAL
REAR MOUNT CLAMP TYPE - CABLE .141

R143.337.000

Series : TNC

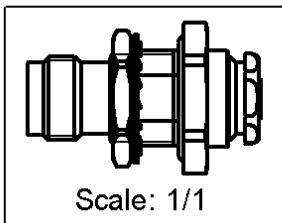
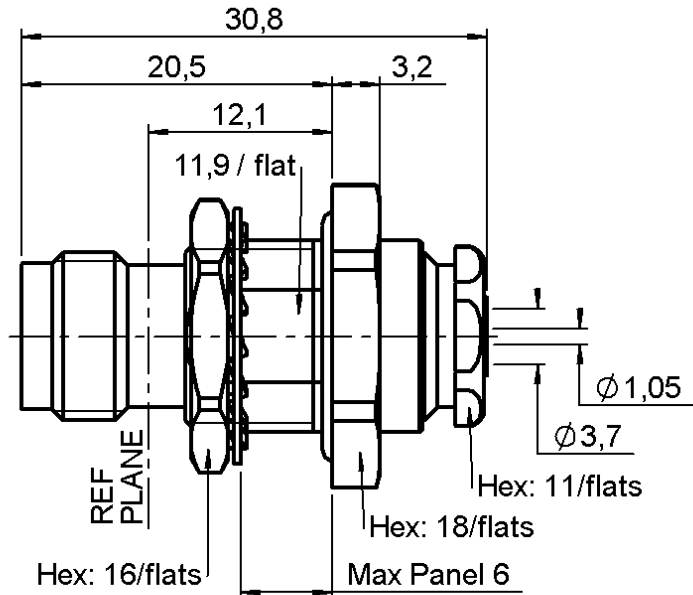

PANEL CUT OUT

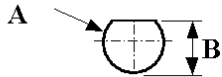

mm		
	Maxi	mini
A	12.8	12.7
B	12.1	12

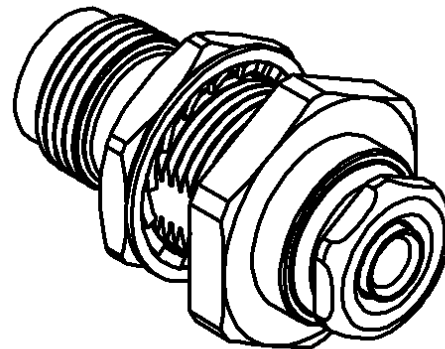

All dimensions are in mm.

COMPONENTS	MATERIALS	PLATING (µm)
BODY	BRASS	NICKEL 2
CENTER CONTACT	BERYLLIUM COPPER	GOLD 0.5 OVER NICKEL 2
OUTER CONTACT	-	-
INSULATOR	PTFE	-
GASKET	SILICONE RUBBER	-
OTHERS PARTS	BRASS	NICKEL 2
-	-	-
-	-	-

Issue : 0707 P

In the effort to improve our products, we reserve the right to make changes judged to be necessary.



STRAIGHT BULKHEAD JACK PANEL SEAL

R143.337.000

REAR MOUNT CLAMP TYPE - CABLE .141

Series : TNC

PACKAGING

Standard	Unit	Other
100	'W' option	Contact us

SPECIFICATION

ELECTRICAL CHARACTERISTICS

Impedance		50 Ω
Frequency		0-11 GHz
VSWR	1.30 +	0,0000 x F(GHz) Maxi
Insertion loss		0.06 √F(GHz) dB Maxi
RF leakage	- (57 - F(GHz)) dB Maxi
Voltage rating		500 Veff Maxi
Dielectric withstanding voltage		1500 Veff mini
Insulation resistance		5000 MΩ mini

CABLE ASSEMBLY

Stripping	a	b	c	d	e	f
mm	0,00	5,10	0,00	0,00	0,00	0,00

Assembly instruction : **Clamp 04**

Recommended cable(s)
RG 402
KS 2

Characteristics indicated on this data sheet are those that can be achieved with the highest performance cable. Intrinsic limitations of the cable may diminish the performance of the assembly

Cable retention

- pull off **270** N mini
- torque **NA** N.cm

MECHANICAL CHARACTERISTICS

Center contact retention		
Axial force – Mating end	NA	N mini
Axial force – Opposite end	NA	N mini
Torque	NA	N.cm mini

TOOLING

Part Number	Description	Hexagon
.	.	.

Recommended torque		
Mating	NA	N.cm
Panel nut	370	N.cm
Clamp nut	450	N.cm
A/F clamp nut	11,0000	mm

Mating life	500	Cycles mini
Weight	22,2500	g

OTHER CHARACTERISTICS

-

ENVIRONMENTAL

Operating temperature	-65/+105	° C
Hermetic seal	NA	Atm.cm3/s
Panel leakage	NA	

Issue : 0707 P

In the effort to improve our products, we reserve the right to make changes judged to be necessary.

