

MATERIALS		
COMPONENT NAME	BASE MATERIAL	FINISH
CASE	LCP, BLACK, UL94 V-0	
TERMINAL, WIRE LUG (GOLD)	BRASS	GOLD OVER NICKEL
TERMINAL, PC & RA (GOLD)	BRASS	GOLD OVER NICKEL IN CONTACT AREA, TIN OVER NICKEL IN SOLDER AREA
TERMINAL, VRA (GOLD)	BRASS	GOLD OVER NICKEL IN CONTACT AREA, TIN OVER NICKEL IN SOLDER AREA
TERMINAL, WIRE LUG (SILVER)	SILVER CLAD COPPER	SILVER OVER NICKEL
TERMINAL, PC (SILVER)	SILVER CLAD COPPER	SILVER OVER NICKEL
CONTACT (GOLD)	COPPER ALLOY OR BRASS	GOLD OVER NICKEL
CONTACT (SILVER)	SILVER CLAD COPPER OR COPPER	SILVER OVER NICKEL
FRAME	STEEL	TIN OVER COPPER
SPRING	MUSIC WIRE	
PLUNGER BUTTON	NYLON 6/6, BLACK, RED OR BLUE, UL94 HB (EXTENDED) OR UL94V-2 (FLUSH)	
SUPPORT BRACKET (RA*ES VERSIONS ONLY)	BRASS	TIN OVER COPPER
SUPPORT BRACKET VRA (B&C BUSHINGS ONLY)	STEEL	TIN OVER COPPER
BUSHING	BRASS	NICKLE OVER COPPER
MOUNTING NUT	BRASS	NICKEL
LOCKWASHER	STEEL	NICKEL
ES HOUSING	NYLON 6/6, NATURAL, UL94 V-2	
ES BOOT	VINYL PLASTISOL, BLACK	

PART NUMBER MATRIX									
MODEL	ACTUATOR	POLES	RATING	FUNCTION	PLATING	TERMINATIONS	PROCESS SEAL	BUTTON COLOR	04
TPC	BLANK=EXTENDED	1	1=GOLD .4VA	C=SPST MOMENTARY	G=GOLD	BLANK=WIRE LUG	ES=PROCESS SEALED	0=BLACK	
	F=FLUSH 1	2	3=SILVER 1 AMP ²	F=SPDT MOMENTARY	BLANK=SILVER ²	PC=PRINTED CIRCUIT		2=RED	
				M=DPST MOMENTARY		RA=RIGHT ANGLE 3		6=BLUE	
				R=DPDT MOMENTARY		VRA=VERTICAL RIGHT ANGLE			

NOTES:

- AVAILABLE WITH B & C BUSHINGS ONLY
- SILVER ONLY AVAILABLE IN WIRE LUG AND PC TERMINATIONS
- RAES AVAILABLE WITH B & C BUSHING ONLY
- VRA ONLY AVAILABLE IN SINGLE POLE

SPECIFICATIONS	
RATING	GOLD: .4VA MAX. @ 20VDC OR PEAK AS RESISTIVE SILVER: 1A @ 125VAC OR 28 VDC RESISTIVE
INITIAL TERMINATION RESISTANCE	20 MILLIOHMS MAX.
INSULATION RESISTANCE	1,000 MEGOHMS MIN @ 500 VDC
DIELECTRIC STRENGTH	1,000 VOLTS RMS AT SEA LEVEL
TIMING	BREAK BEFORE MAKE
PLUNGER TRAVEL	.030
ACTUATION FORCE	50 TO 400 GRAMS
LIFE EXPECTANCY	.4 VA, 1 POLE: 100,000 .4 VA, 2 POLES: 80,000 1 A, 1 POLE: 60,000 1 A, 2 POLES: 50,000
OPERATING TEMPERATURE	-30°C TO +65°C
STORAGE TEMPERATURE	-30°C TO +65°C
TERMINAL SEAL	SINGLE POLE: EPOXY DOUBLE POLE: EPOXY OPTIONAL

- TERMINAL NUMBERS ARE FOR REFERENCE ONLY AND DO NOT APPEAR ON SWITCHES
 - ALL MATERIALS AND FINISHES COMPLY WITH EU DIRECTIVE 2002/95/EC OF 27JAN2003 (ROHS)
 - DISPOSABLE BOOT SUPPLIED WITH ES VERSIONS. BOOT TO BE PLACED OVER BUSHING BEFORE SOLDER WASHING
- 4 CENTER TERMINAL PRESENT ON DOUBLE THROW SWITCHES ONLY.

	P/N	ALCO P/N	FLUSH ACTUATOR	POLES	THROWS	PLATING	TERMINALS	PROCESS SEALED	BUTTON COLOR	FUNCTION				CONNECTED TERMINALS		DIM A
										OFF	MOM	ON	MOM	1-3	4-6	
	1825098-1	TPC11CGPC004	NO	1	1	GOLD	PC	NO	BLACK	OFF	MOM	OFF	1-3		.133	
	1825098-2	TPC11CGRA004	NO	1	1	GOLD	RIGHT ANGLE	NO	BLACK	OFF	MOM	OFF	1-3		.133	
OBSOLETE	1825098-3	TPC11CGRA204	NO	1	1	GOLD	RIGHT ANGLE	NO	RED	OFF	MOM	OFF	1-3		.133	
	1825098-4	TPC11CGVRA004	NO	1	1	GOLD	VRA	NO	BLACK	OFF	MOM	OFF	1-3		N/A	
	1825098-5	TPC11FGPC004	NO	1	2	GOLD	PC	NO	BLACK	ON	MOM	OFF	1-2	2-3	.133	
	1825098-6	TPC11FGRA004	NO	1	2	GOLD	RIGHT ANGLE	NO	BLACK	ON	MOM	OFF	1-2	2-3	.133	
	1825098-7	TPC11FGVRA004	NO	1	2	GOLD	VRA	NO	BLACK	ON	MOM	OFF	1-2	2-3	N/A	
	1825098-8	TPC11FGVRA204	NO	1	2	GOLD	VRA	NO	RED	ON	MOM	OFF	1-2	2-3	N/A	
	1825098-9	TPC13C004	NO	1	1	SILVER	WIRE LUG	NO	BLACK	OFF	MOM	OFF	1-3		.133	
	1-1825098-0	TPC13C204	NO	1	1	SILVER	WIRE LUG	NO	RED	OFF	MOM	OFF	1-3		.133	
OBSOLETE	1-1825098-1	TPC13CPC004	NO	1	1	SILVER	PC	NO	BLACK	OFF	MOM	OFF	1-3		.133	
	1-1825098-2	TPC13F004	NO	1	2	SILVER	WIRE LUG	NO	BLACK	ON	MOM	OFF	1-2	2-3	.133	
	1-1825098-3	TPC21MGRA204	NO	2	1	GOLD	RIGHT ANGLE	NO	RED	OFF	MOM	OFF	1-3, 4-6		N/A	
	1-1825098-4	TPC21RGPC004	NO	2	2	GOLD	PC	NO	BLACK	ON	MOM	OFF	1-2, 4-5	2-3, 5-6	N/A	
	1-1825098-5	TPC23M004	NO	2	1	SILVER	WIRE LUG	NO	BLACK	OFF	MOM	OFF	1-3, 4-6		N/A	
	1-1825098-6	TPC23R204	NO	2	2	SILVER	WIRE LUG	NO	RED	ON	MOM	OFF	1-2, 4-5	2-3, 5-6	N/A	
	1-1825098-7	TPCF11CGPC004	YES	1	1	GOLD	PC	NO	BLACK	OFF	MOM	OFF	1-3		.000	
OBSOLETE	1-1825098-8	TPCF11CGRA004	YES	1	1	GOLD	RIGHT ANGLE	NO	BLACK	OFF	MOM	OFF	1-3		.000	
	1-1825098-9	TPCF11FGRA004	YES	1	2	GOLD	RIGHT ANGLE	NO	BLACK	ON	MOM	OFF	1-2	2-3	.000	
	2-1825098-0	TPCF13C004	YES	1	1	SILVER	WIRE LUG	NO	BLACK	OFF	MOM	OFF	1-3		.000	
	2-1825098-1	TPCF13C004	YES	1	2	SILVER	WIRE LUG	NO	BLACK	ON	MOM	OFF	1-2	2-3	.000	

THIS DRAWING IS A CONTROLLED DOCUMENT. DIMENSIONS: INCHES. TOLERANCES UNLESS OTHERWISE SPECIFIED: 0 PLC ± .010, 1 PLC ± .010, 2 PLC ± .010, 3 PLC ± .010, 4 PLC ± .010. MATERIAL: FINISH: WEIGHT: RESTRICTED TO: CUSTOMER DRAWING. SCALE: 4:1 SHEET 1 OF 5 REV A2.

STE TE Connectivity
PUSHBUTTON SWITCH, TPC SERIES

APVD: NAME: PRODUCT SPEC: APPLICATION SPEC: SIZE: A1 CAGE CODE: 00779 DRAWING NO: 1825098

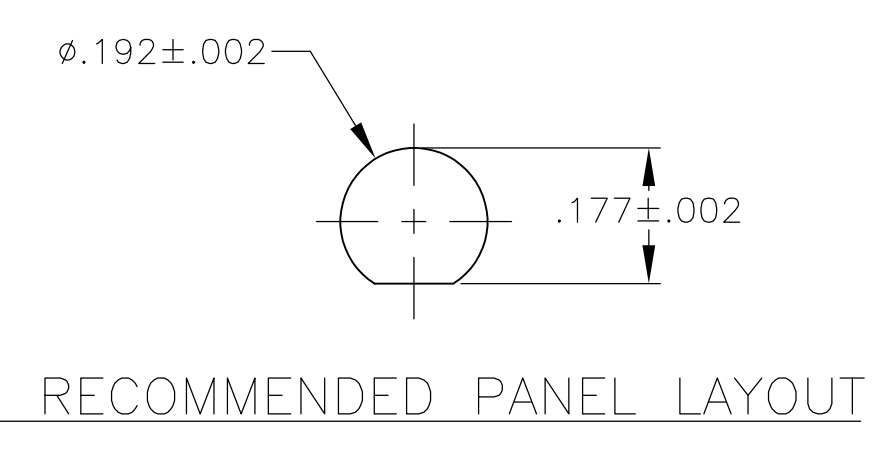
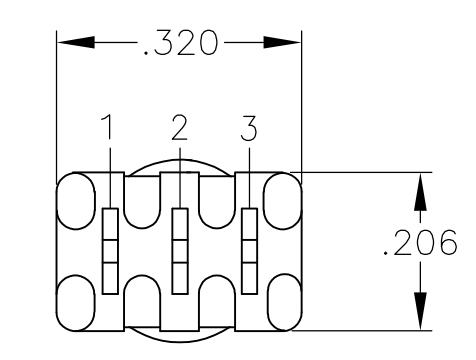
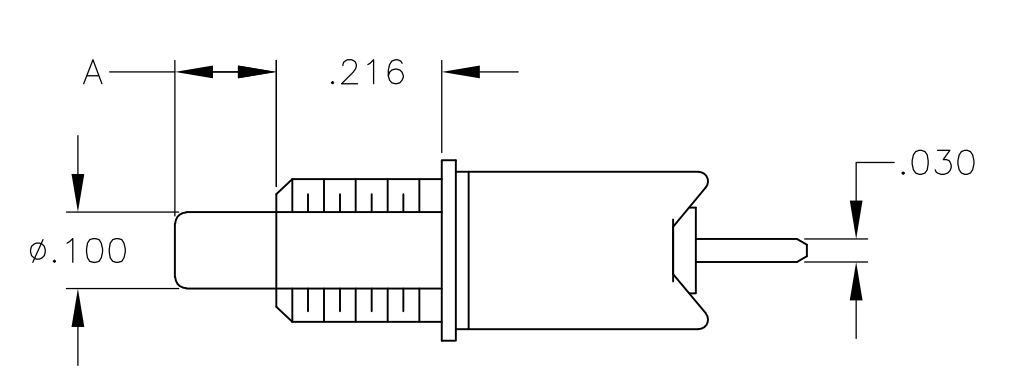
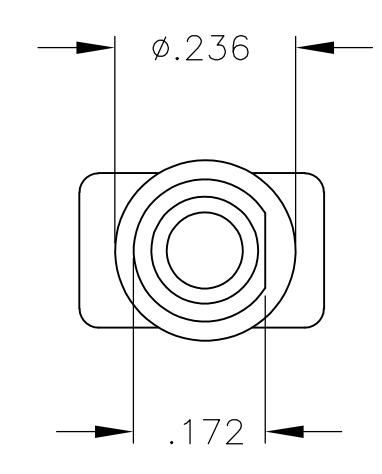
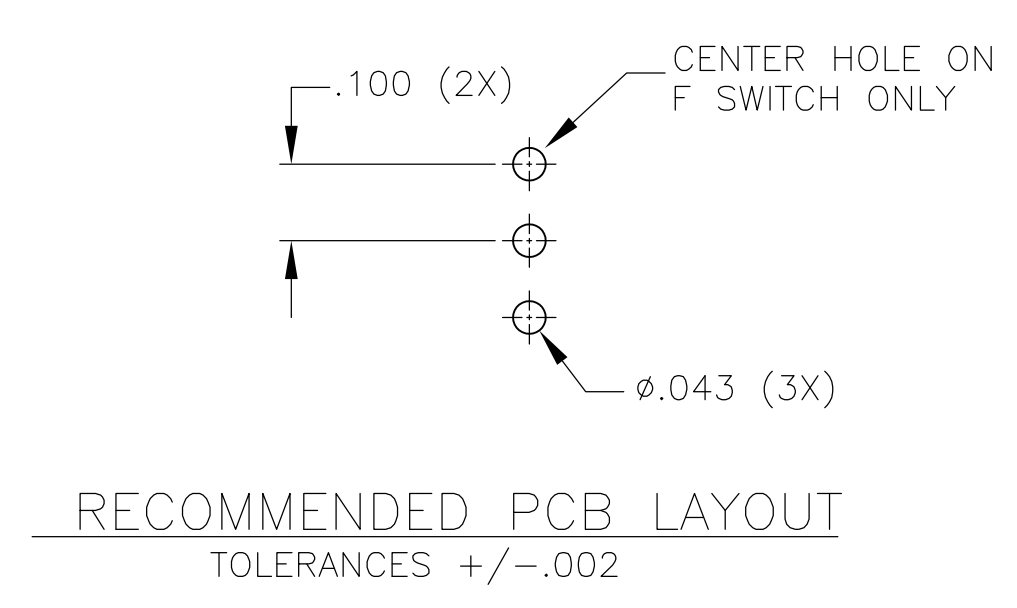
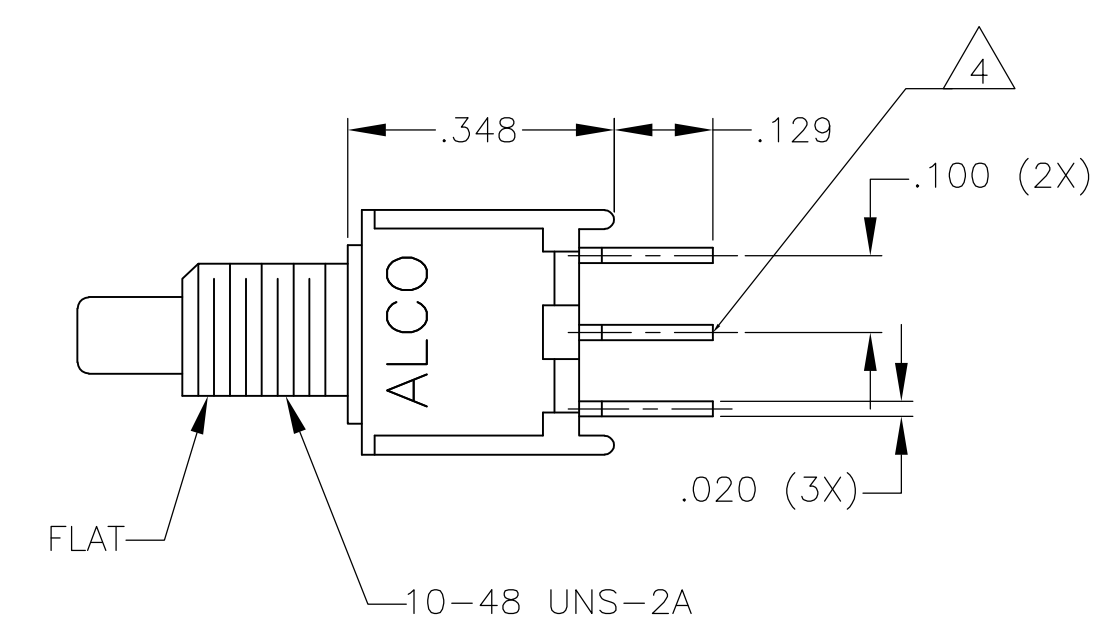

TPC11CGPC, TPC11FGPC
TPCF11CGPC, TPC13CPC

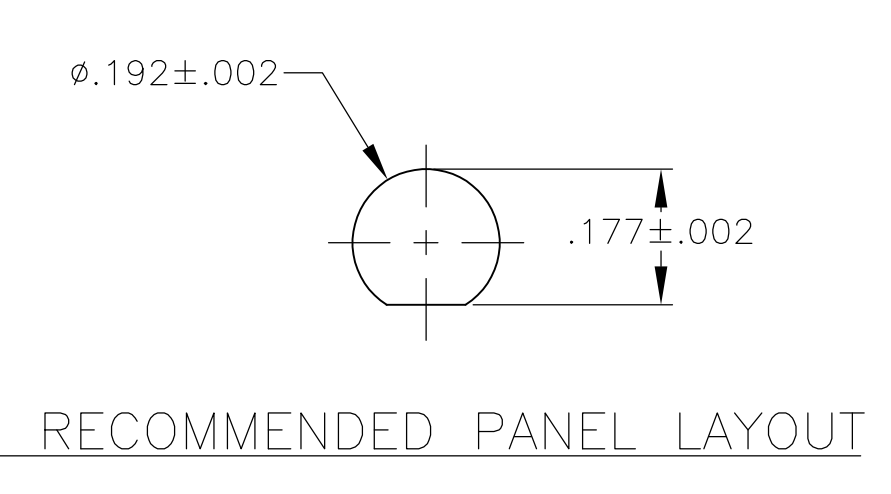
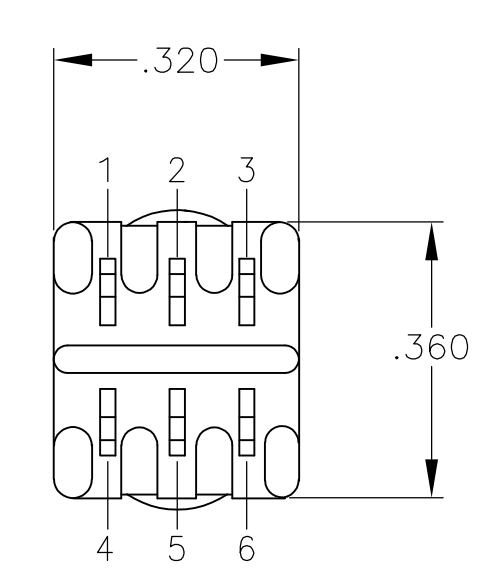
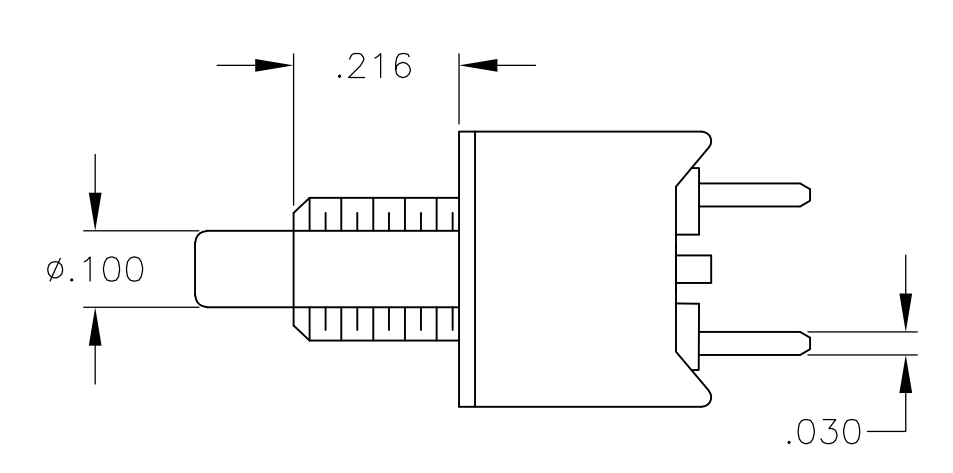
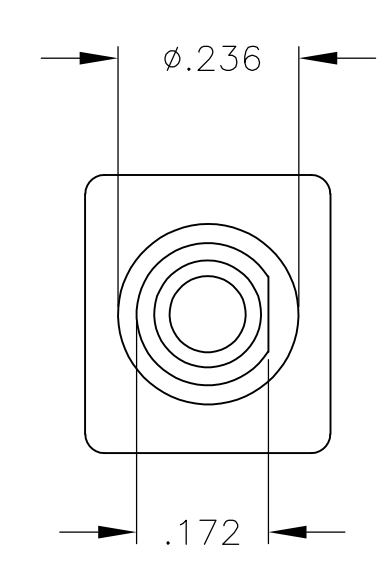
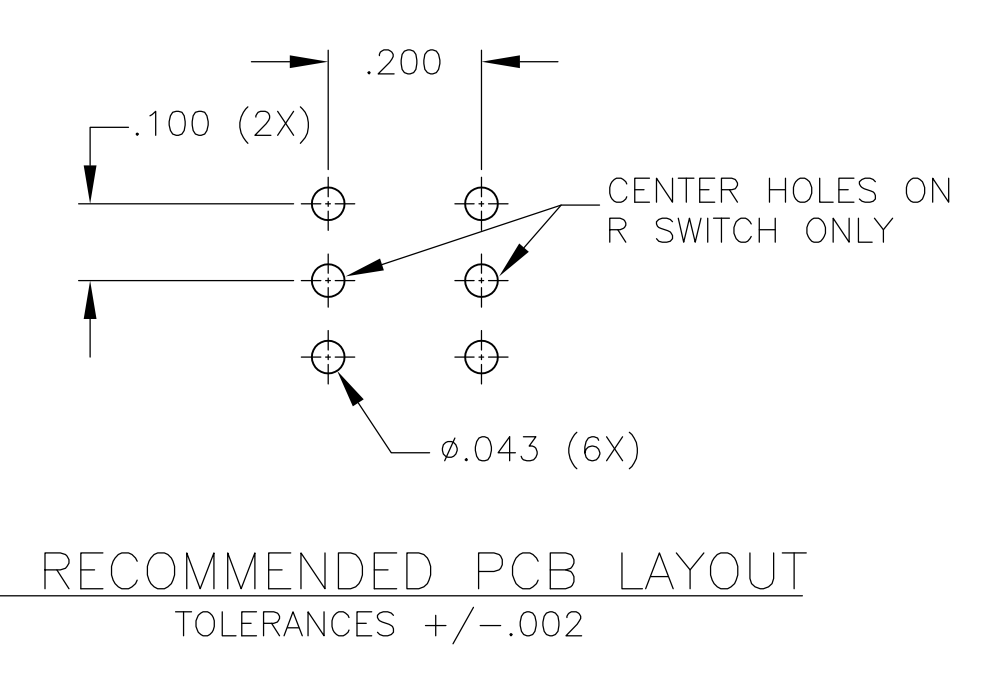
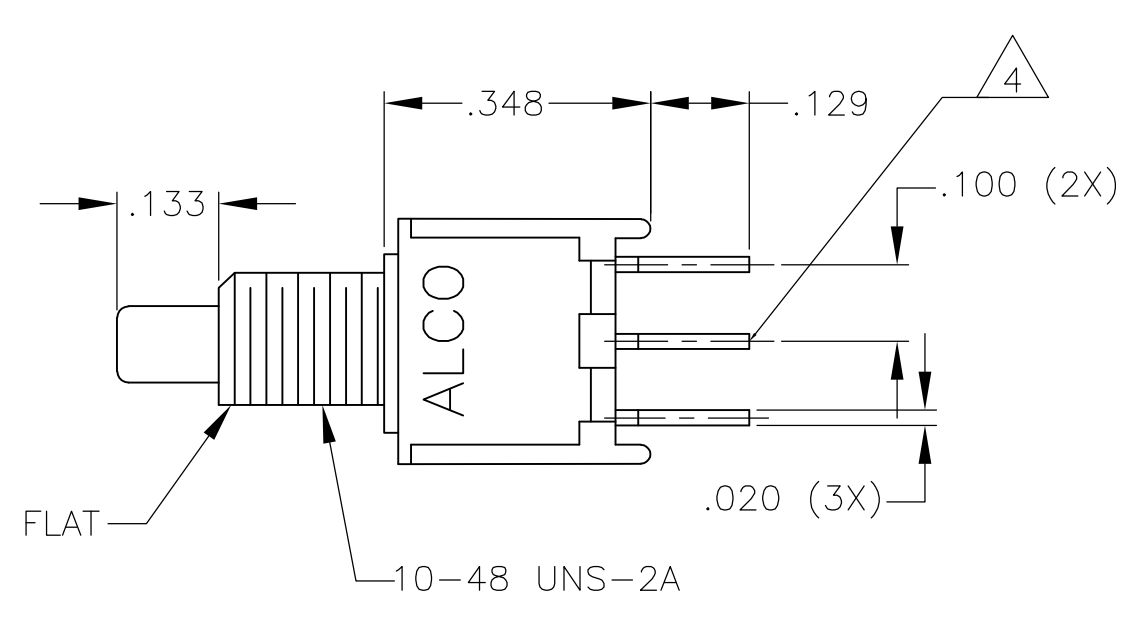

TPC21RGPC

THIS DRAWING IS A CONTROLLED DOCUMENT.		DRN	12-5-05	TE TE Connectivity	
		CHK			
DIMENSIONS:	TOLERANCES UNLESS OTHERWISE SPECIFIED:	APVD		NAME	
INCHES				PRODUCT SPEC	
	0. PLC ± -			APPLICATION SPEC	
	1. PLC ± -				
	2. PLC ± -				
	3. PLC ± .010				
	4. PLC ± -				
	ANGLES ± °				
	FINISH -				
		SIZE	A1	CAGE CODE	00779
		DRAWING NO	1825098		RESTRICTED TO
		WEIGHT			
		CUSTOMER DRAWING	SCALE	4:1	SHEET 2 OF 5
				REV	A2

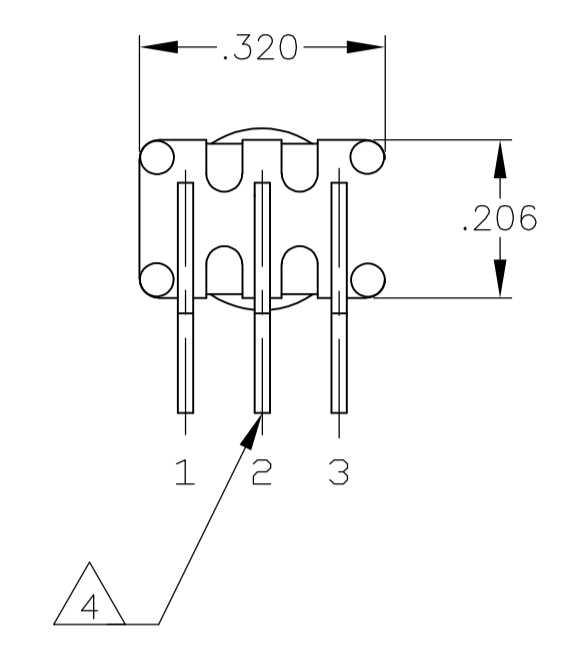
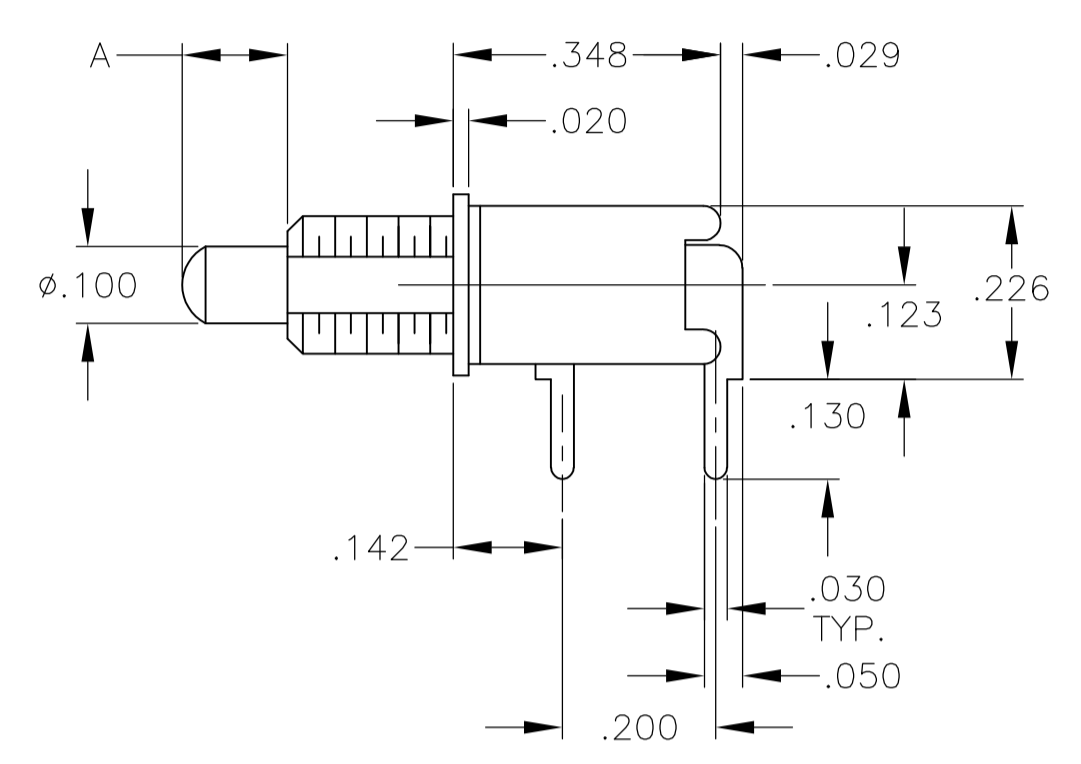
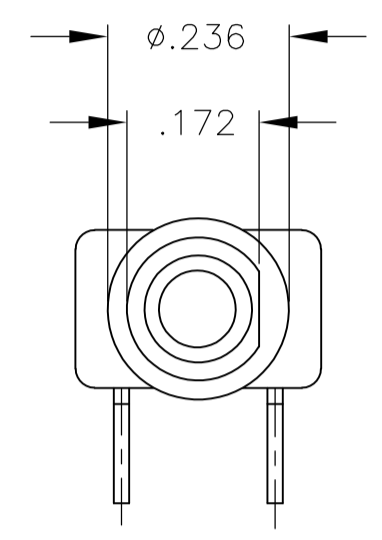
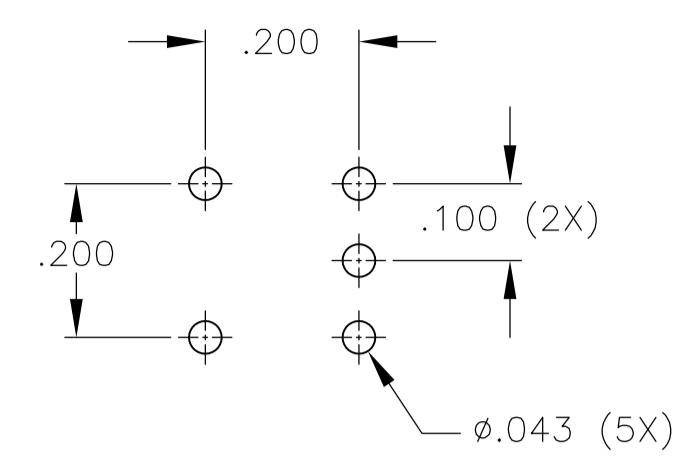
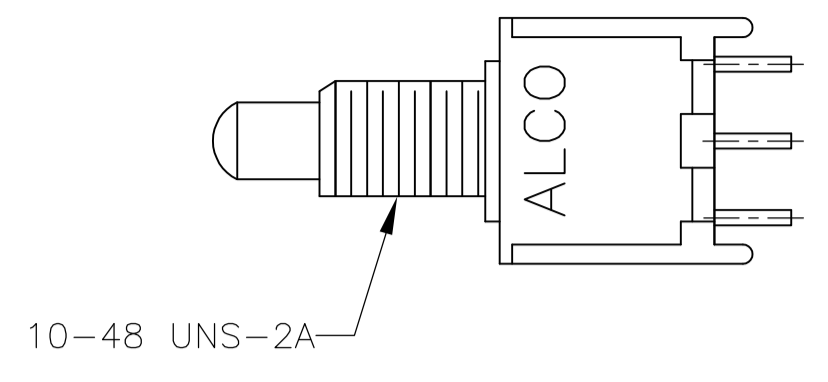

RECOMMENDED PCB LAYOUT
TOLERANCES +/- .002

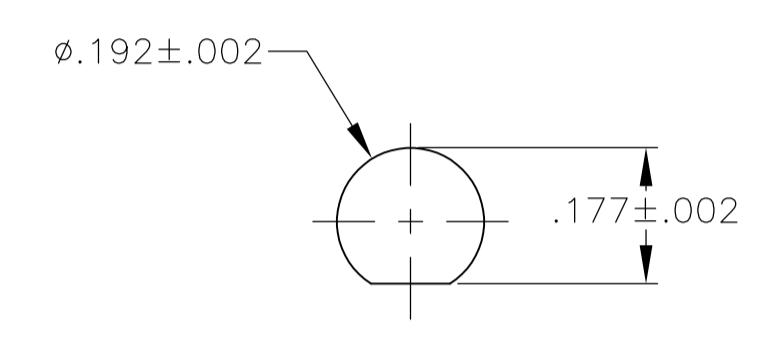

RECOMMENDED PANEL LAYOUT

TPC11CGRA, TPC11FGRA
TPCF11CGRA, TPCF11FGRA

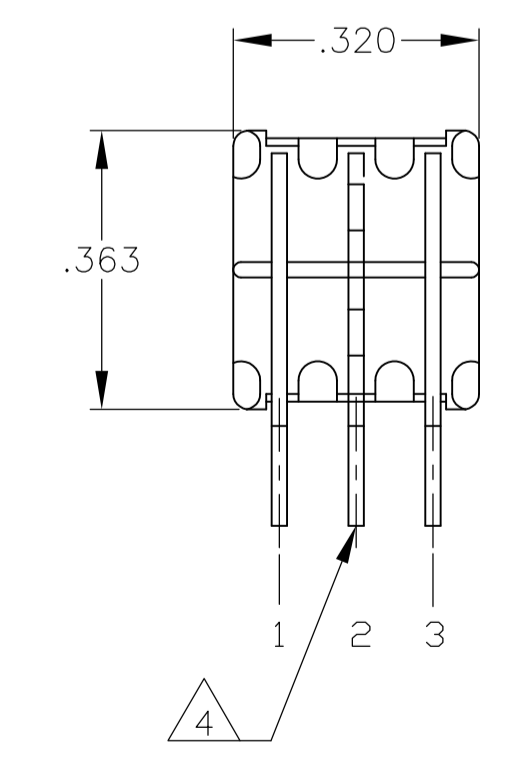
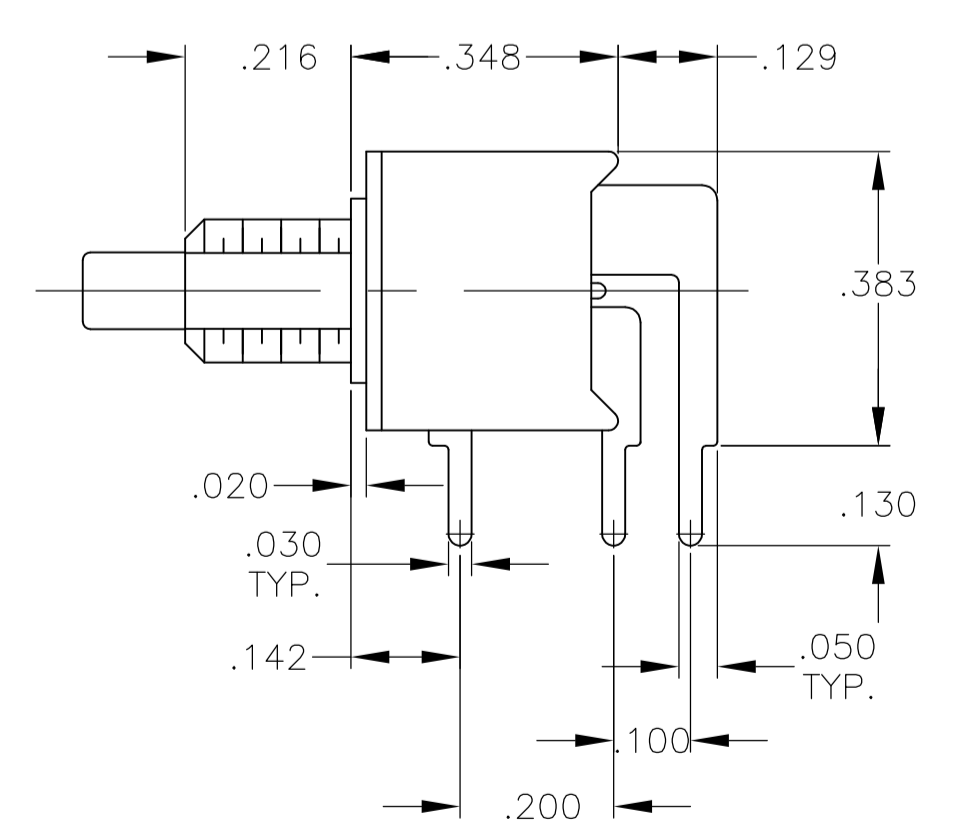
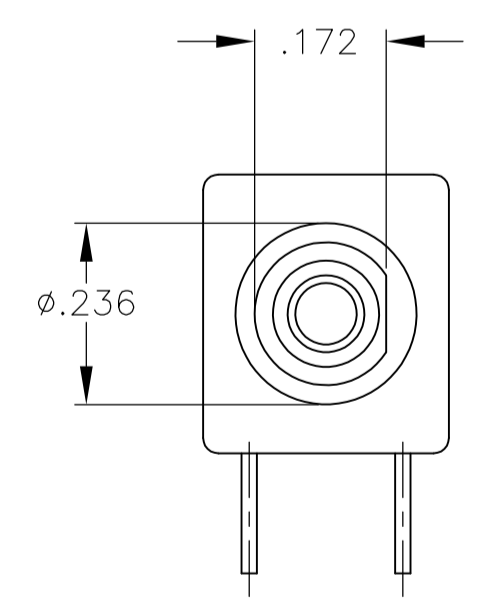
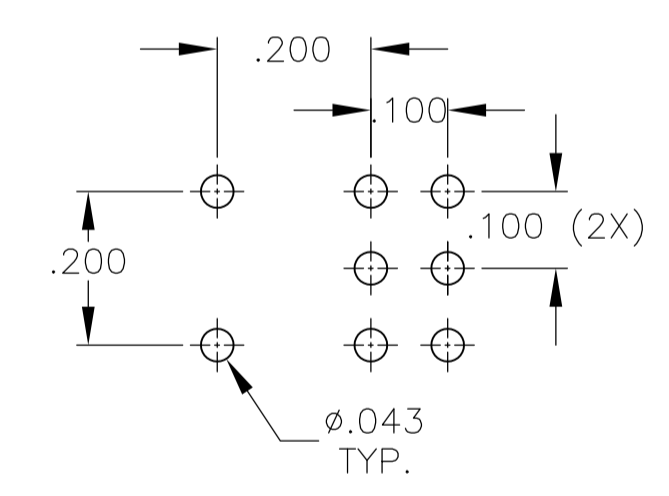
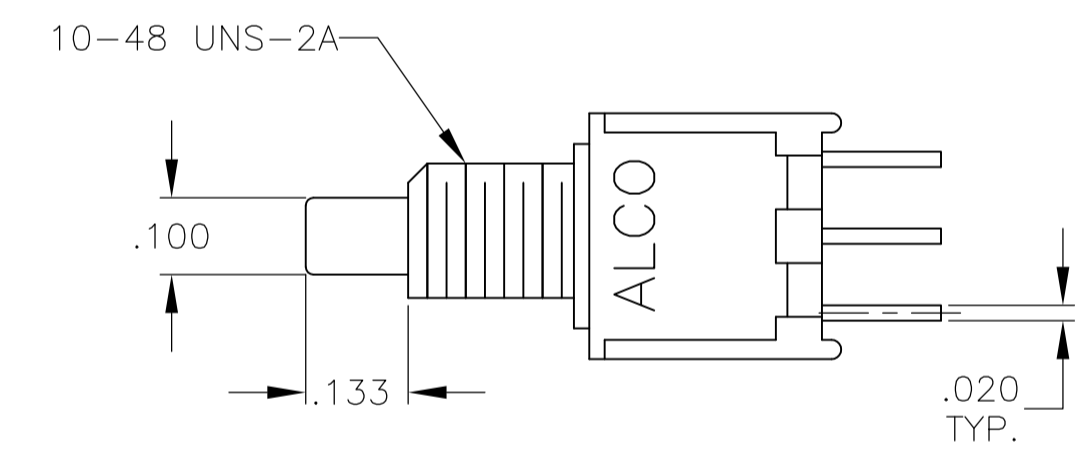

RECOMMENDED PCB LAYOUT
TOLERANCES +/- .002

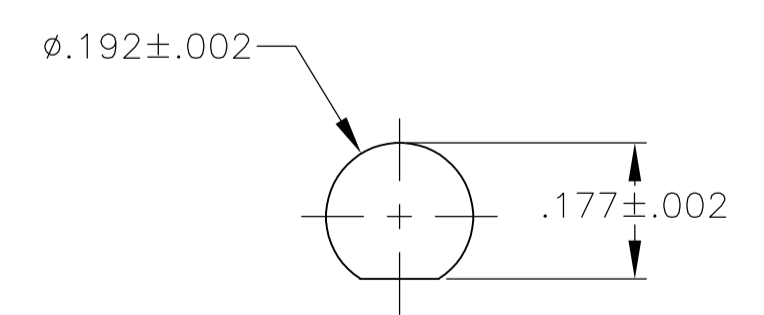

RECOMMENDED PANEL LAYOUT

TPC21MGRA

THIS DRAWING IS A CONTROLLED DOCUMENT.		DIN	12-5-05	RAGHU		TE Connectivity	
DIMENSIONS: INCHES		CHK		APVD		NAME	
TOLERANCES UNLESS OTHERWISE SPECIFIED:		0 PLC ± -		PRODUCT SPEC		PUSHBUTTON SWITCH, TPC SERIES	
		1 PLC ± -		APPLICATION SPEC		SIZE	
		2 PLC ± -		APV		CAGE CODE	
		3 PLC ± .010		A1		DRAWING NO	
		4 PLC ± -		00779		1825098	
		ANGLES ± °		WEIGHT		RESTRICTED TO	
MATERIAL		FINISH		CUSTOMER DRAWING		SCALE	
				4:1		SHEET 3 OF 5	
						REV A2	

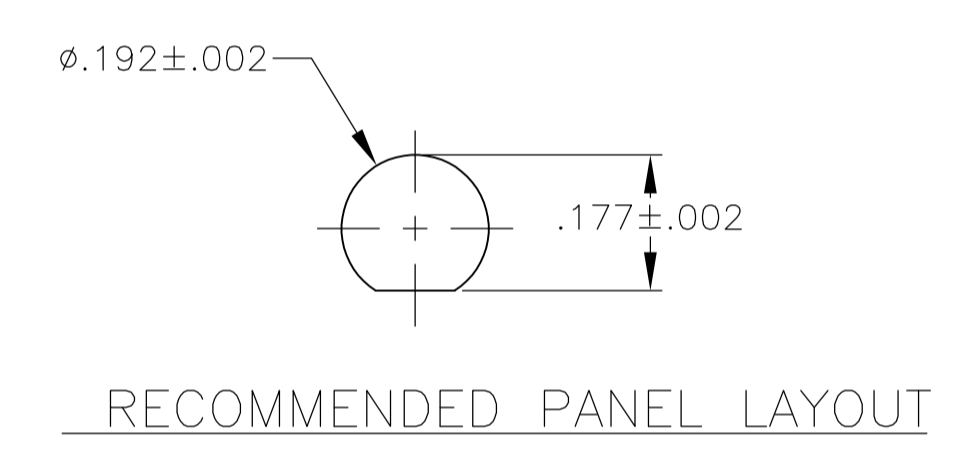
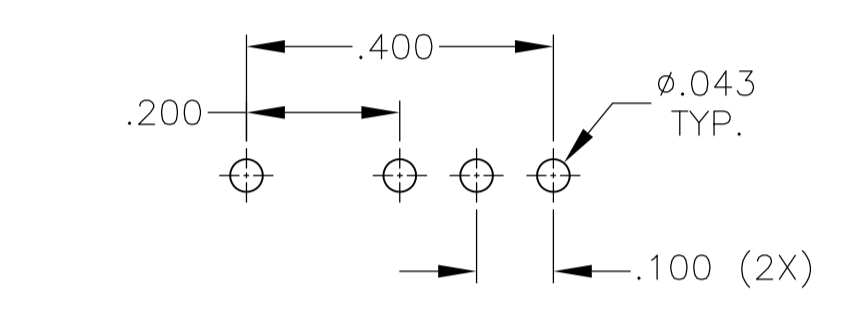
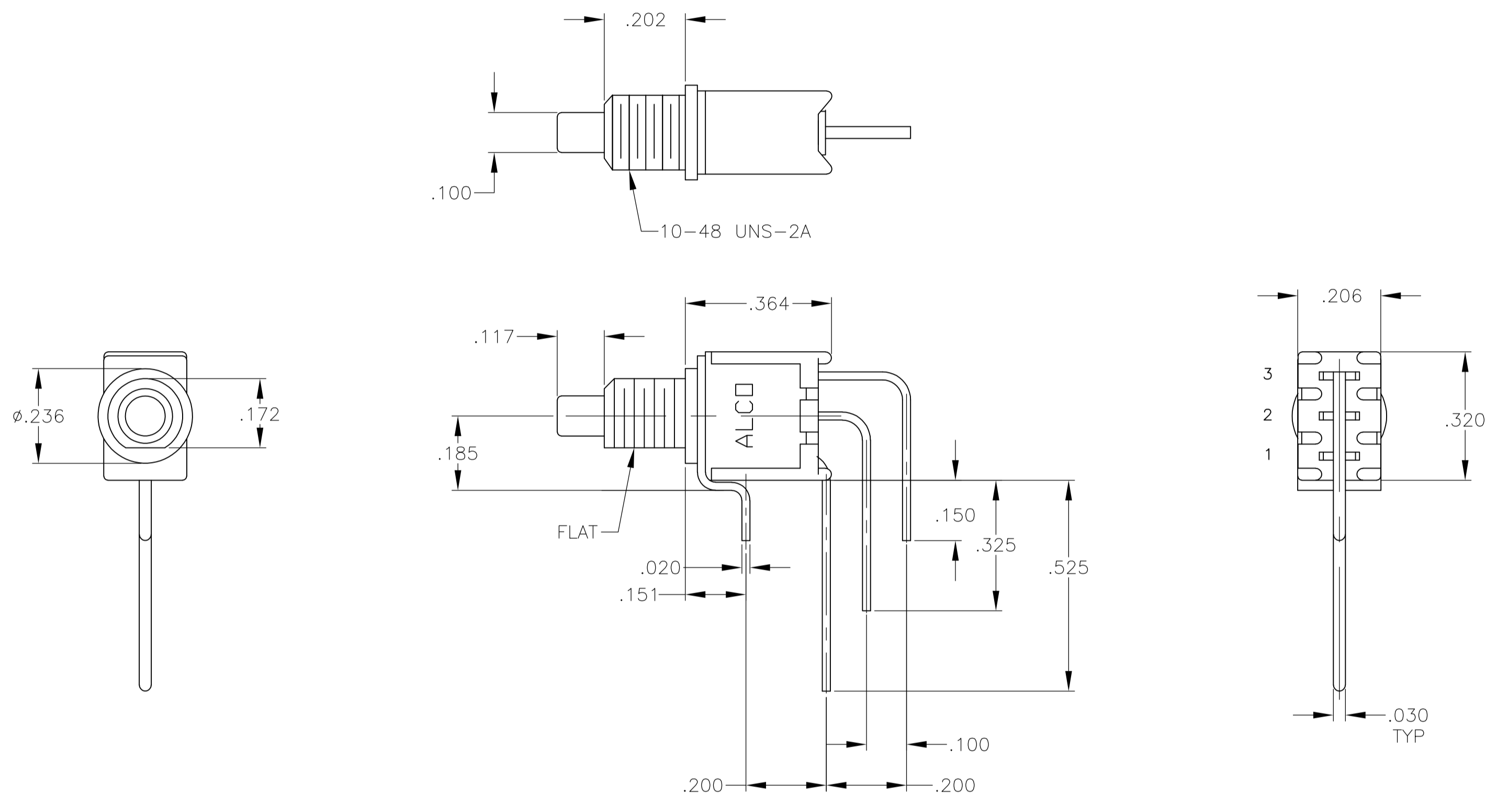

TPC11CGVRA, TPC11FGVRA

THIS DRAWING IS A CONTROLLED DOCUMENT.		DNW RAGHU	12-5-05		
DIMENSIONS: INCHES		CHK	-		
TOLERANCES UNLESS OTHERWISE SPECIFIED:		APVD	-	NAME	
<ul style="list-style-type: none"> 0. PLC ± - 1. PLC ± - 2. PLC ± - 3. PLC ± .010 4. PLC ± - ANGLES ± 3' FINISH - 		PRODUCT SPEC		PUSHBUTTON SWITCH, TPC SERIES	
MATERIAL		APPLICATION SPEC		SIZE	RESTRICTED TO
-		-		A1	-
CUSTOMER DRAWING		SCALE 4:1		SHEET 4 OF 5	REV A2

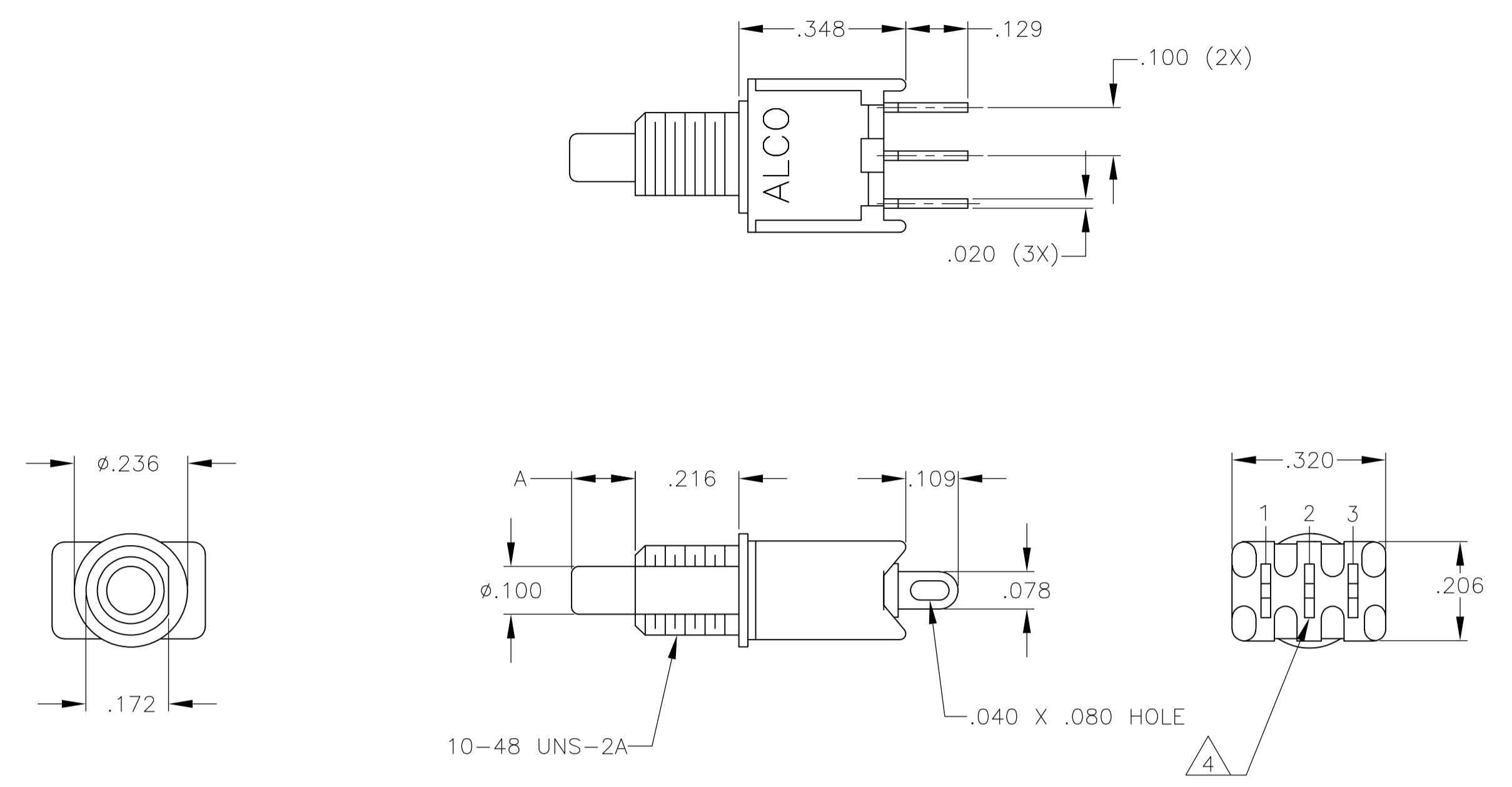

TPC13C, TPC13F,
TPCF13C, TPC13F

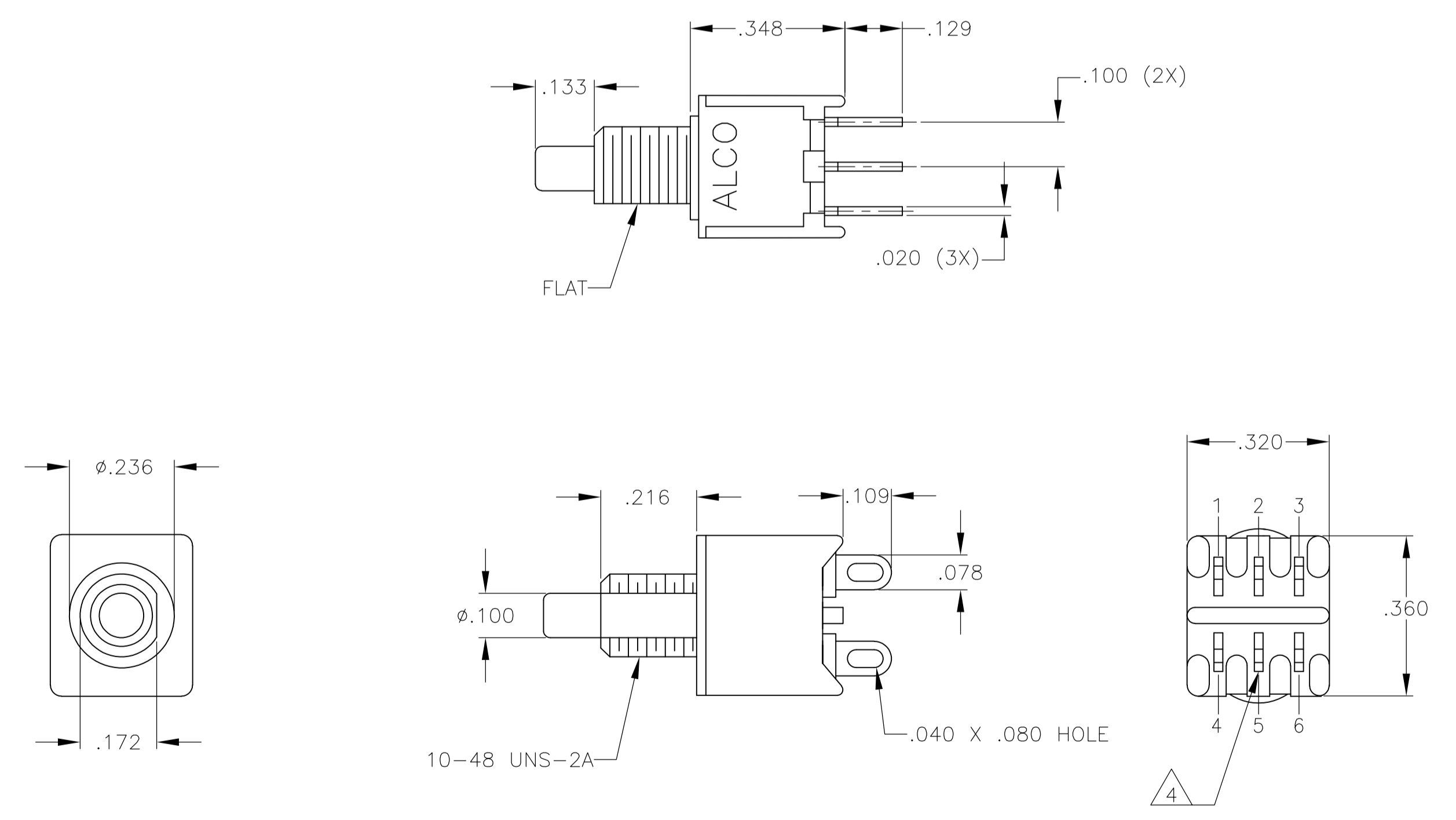
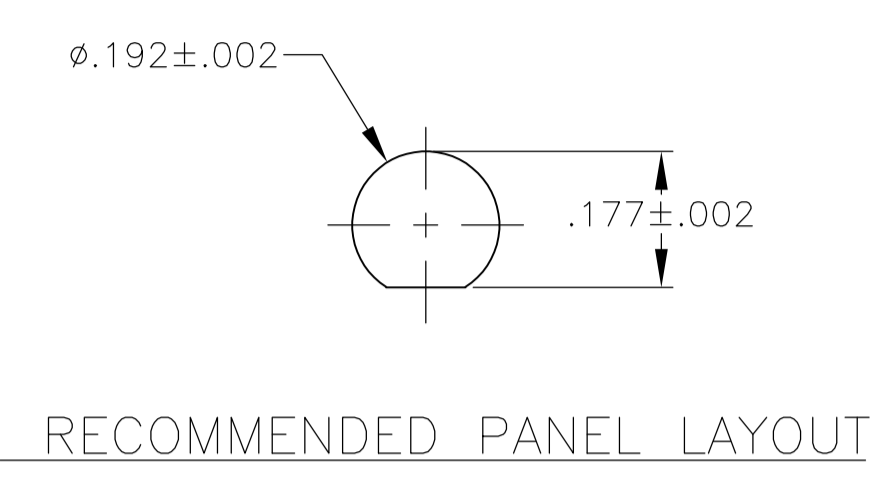

TPC23M, TPC23R

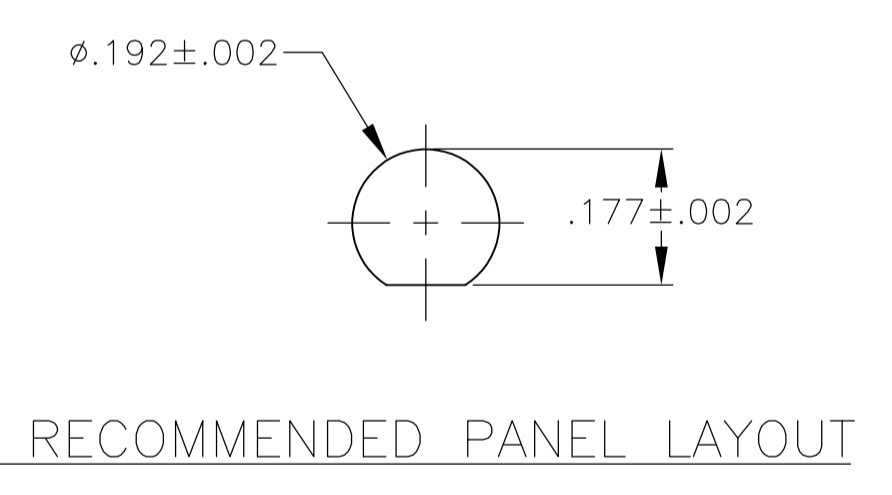

THIS DRAWING IS A CONTROLLED DOCUMENT.		DIN	12-5-05	RAGHU	
DIMENSIONS: INCHES		CHK	-	-	
TOLERANCES UNLESS OTHERWISE SPECIFIED:		APVD	-	NAME	
0. PLC	± .010	PRODUCT SPEC		-	
1. PLC	± .010	APPLICATION SPEC		-	
2. PLC	± .010	SIZE		A1	
3. PLC	± .010	CAGE CODE		00779	
4. PLC	± .010	DRAWING NO		1825098	
ANGLES	± .5°	WEIGHT		-	
MATERIAL	-	FINISH		-	
CUSTOMER DRAWING		SCALE		4:1	
SHEET		5		OF 5	
REV		A2		-	