

# 22 channel multiple switch detection interface with programmable wetting current

The 33978 is designed to detect the closing and opening of up to 22 switch contacts. The switch status, either open or closed, is transferred to the microprocessor unit (MCU) through a serial peripheral interface (SPI). This SMARTMOS device also features a 24-to-1 analog multiplexer for reading the input channels as analog inputs. The analog selected input signal is buffered and provided on the AMUX output pin for the MCU to read.

Independent programmable wetting currents are available as needed for the application. A battery and temperature monitor are included in the IC and available via the AMUX pin.

The 33978 device has two modes of operation, Normal and Low-power mode (LPM). Normal mode allows programming of the device and supplies switch contacts with pull-up or pull-down current as it monitors the change of state on the switches. The LPM provides low quiescent current, which makes the 33978 ideal for automotive and industrial products requiring low sleep-state currents.

## Features

- Fully functional operation  $4.5\text{ V} \leq V_{\text{BATP}} \leq 36\text{ V}$
- Full parametric operation  $6.0\text{ V} \leq V_{\text{BATP}} \leq 28\text{ V}$
- Operating switch input voltage range from  $-1.0\text{ V}$  to  $36\text{ V}$
- Eight programmable inputs (switches to battery or ground)
- 14 switch-to-ground inputs
- Selectable wetting current (2, 6, 8, 10, 12, 14, 16, or 20 mA)
- Interfaces directly to an MCU using 3.3 V / 5.0 V SPI protocol
- Selectable wake-up on change of state
- Typical standby current  $I_{\text{BATP}} = 30\text{ }\mu\text{A}$  and  $I_{\text{DDQ}} = 10\text{ }\mu\text{A}$
- Active interrupt (INT\_B) on change-of-switch state
- Integrated battery and temperature sensing

## Notes

1. The IC is functional from  $4.5\text{ V} < V_{\text{BATP}} < 6.0\text{ V}$ , but with degraded parametric values. The parameters may not meet the minimum and maximum specifications when  $V_{\text{BATP}}$  drops below  $6.0\text{ V}$ .

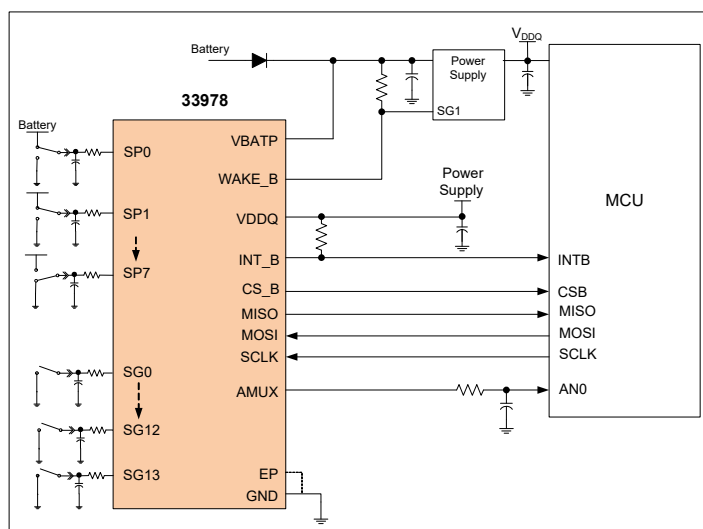

Figure 1. 33978 simplified application diagram

33978  
34978

## MULTIPLE SWITCH DETECTION INTERFACE



EK SUFFIX (PB-FREE)  
98ASA10556D  
32-PIN SOICW-EP



ES SUFFIX (PB-FREE)  
98ASA00656D  
32-PIN QFN (WF-TYPE)



AE SUFFIX (PB-FREE)  
98ASA00173D  
48-PIN LQFP-EP

## Applications

- Automotive
  - Heating ventilation and air conditioning (HVAC)
  - Lighting
  - Central gateway/in-vehicle networking
  - Gasoline engine management
- Industrial
  - Programmable logic control (PLC)
  - Process control, temperature control
  - Input-output control (I/O Control)
  - Single board computer
  - Ethernet switch

# Table of Contents

1	Orderable parts	3
2	Internal block diagram	4
3	Pin connections	5
3.1	Pinout	5
3.2	Pin definitions	6
4	General product characteristics	7
4.1	Maximum ratings	7
4.2	Thermal characteristics	8
4.3	Operating conditions	9
4.4	Electrical characteristics	9
5	General description	17
5.1	Features	17
5.2	Functional block diagram	18
6	General IC functional description	19
6.1	Battery voltage ranges	19
6.2	Power sequencing conditions	20
7	Functional block description	21
7.1	State diagram	21
7.2	Low-power mode operation	22
7.3	Input functional block	24
7.4	Oscillator and timer control functional block	26
7.5	Temperature monitor and control functional block	26
7.6	WAKE_B control functional block	26
7.7	INT_B functional block	27
7.8	AMUX functional block	27
7.9	Serial peripheral interface (SPI)	28
7.10	SPI control register definition	31
8	Typical applications	53
8.1	Application diagram	53
8.2	Bill of materials	53
8.3	Abnormal operation	54
9	Packaging	55
9.1	Package mechanical dimensions	55
10	Reference section	65
11	Revision history	66

# 1 Orderable parts

This section describes the part numbers available to be purchased along with their differences.

**Table 1. Orderable part variations**

Part number	Temperature (T <sub>A</sub> )	Package	Notes
MC33978AAE	-40 °C to 125 °C	LQFP-EP 48 pin	(2)
MC33978EK	-40 °C to 125 °C	SOICW-EP 32 pins	(2), (3)
MC33978AEK		QFN (WF-TYPE) 32 pins	(2)
MC33978AES			
MC34978EK	-40 °C to 105 °C	SOICW-EP 32 pins	(2), (3)
MC34978AEK		QFN (WF-TYPE) 32 pins	(2)
MC34978AES			

Notes

2. To order parts in tape and reel, add the R2 suffix to the part number.
3. Refer to errata [MC33978ER](#) ER01 for details on current conditions present on the MC33978EK and MC34978EK devices only.

## 2 Internal block diagram

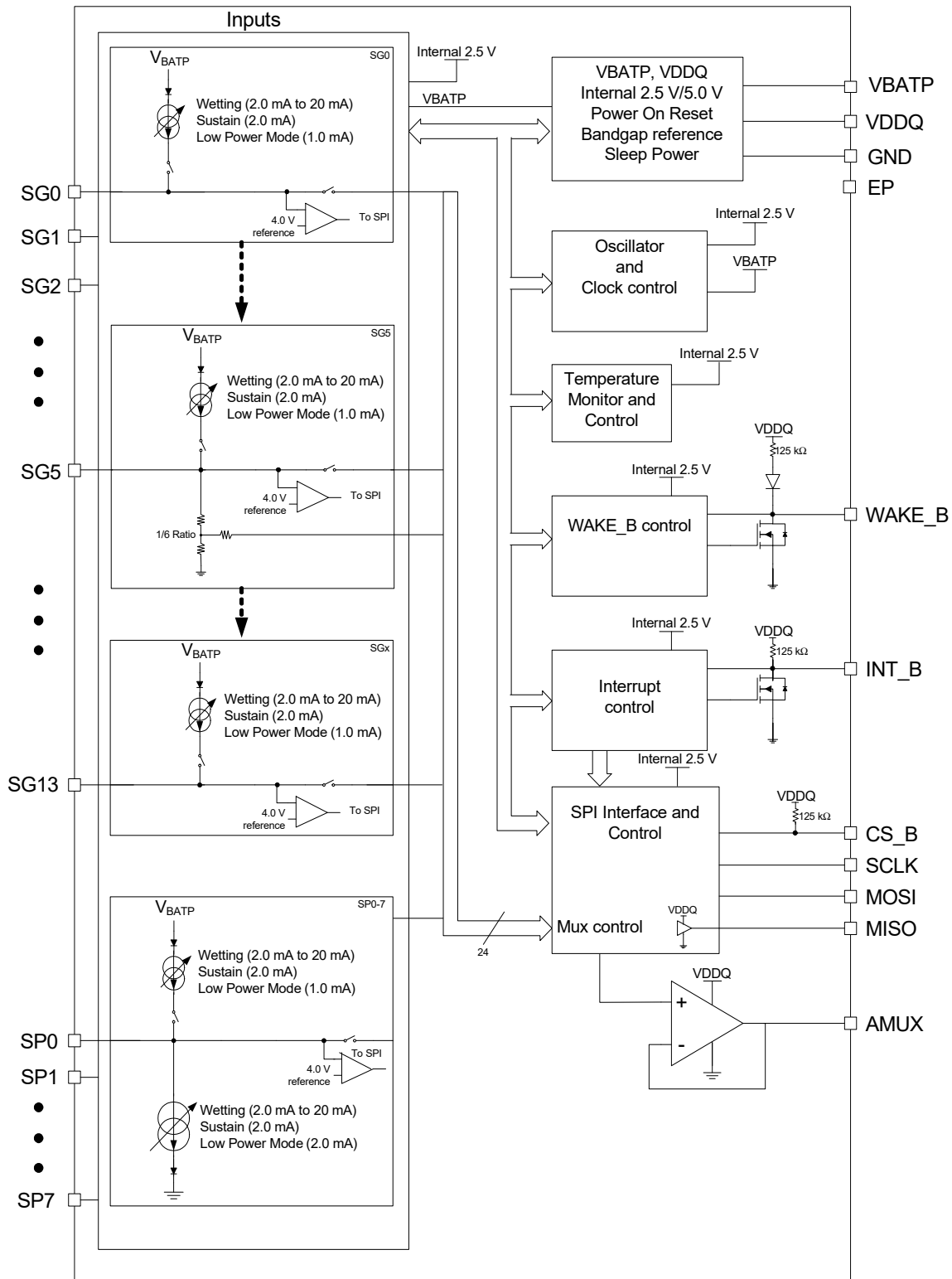
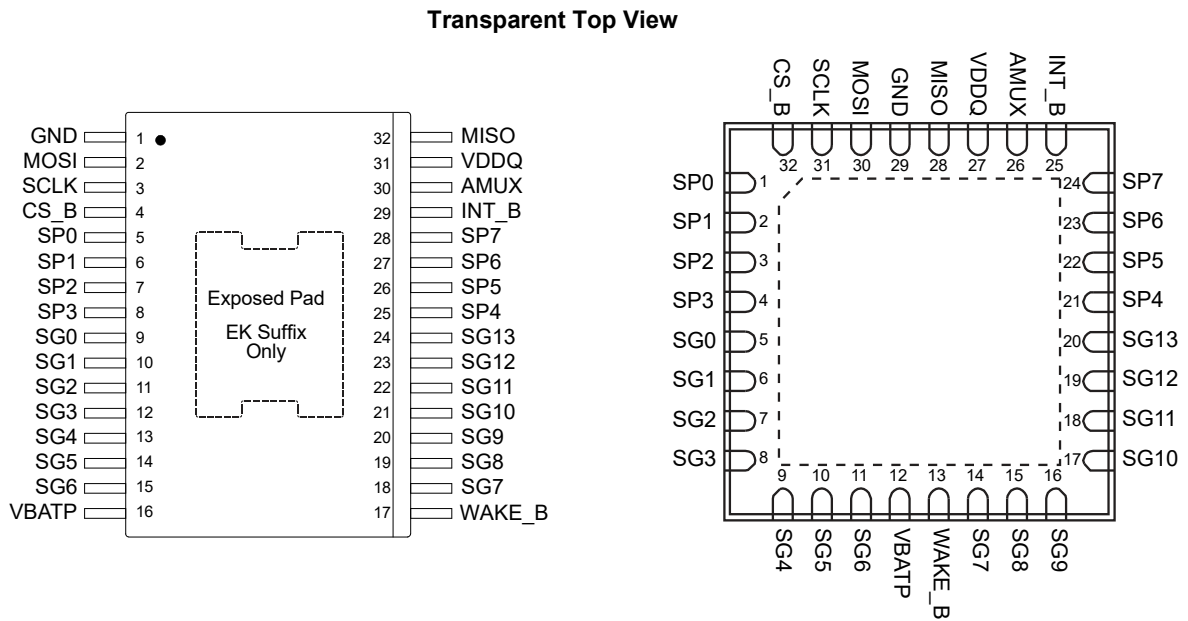

Figure 2. 33978 internal block diagram

# 3 Pin connections

## 3.1 Pinout



**Figure 3. 33978 SOICW-EP and QFN (WF-Type) pinouts**

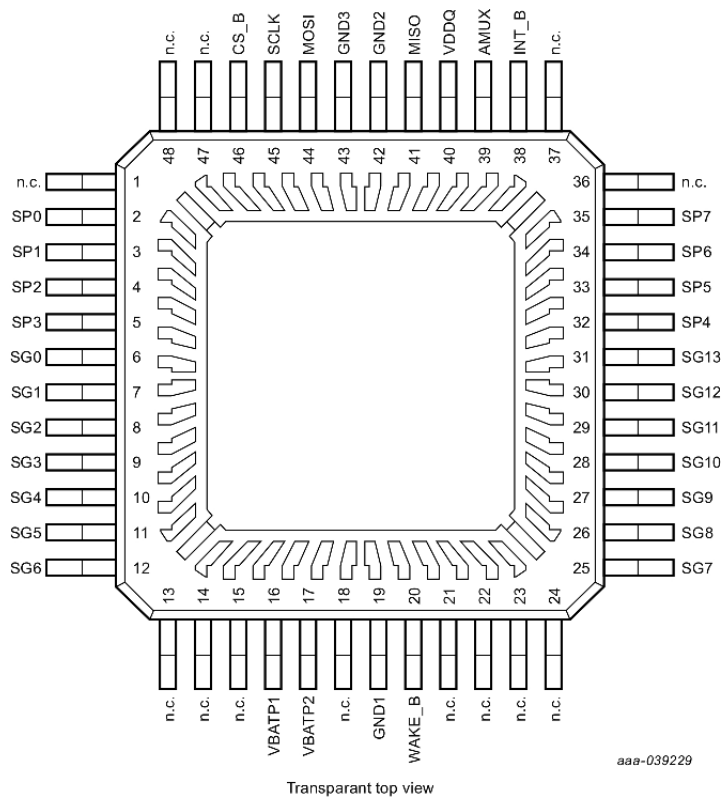

**Figure 4. 33978 LQFP-EP pinout**

## 3.2 Pin definitions

Table 2. 33978 pin definitions

Pin number SOIC	Pin number QFN	Pin number LQFP	Pin name	Pin function	Formal name	Definition
1	29	19, 42, 43	GND	Ground	Ground	Ground for logic, analog
2	30	44	MOSI	Input/SPI	SPI Slave In	SPI control data input pin from the MCU
3	31	45	SCLK	Input/SPI	Serial Clock	SPI control clock input pin
4	32	46	CS_B	Input/SPI	Chip Select	SPI control chip select input pin
5 - 8 25 - 28	1 - 4 21 - 24	2 - 5 32 - 35	SP0-3 SP4-7	Input	Programmable Switches 0-7	Switch to programmable input pins (SB or SG)
9 - 15, 18 - 24	5 - 11 14 - 20	6 - 12 25 - 31	SG0-6, SG7-13	Input	Switch-to-Ground Inputs 0-13	Switch-to-ground input pins
16	12	16, 17	VBATP	Power	Battery Input	Battery supply input pin. Pin requires external reverse battery protection
17	13	20	WAKE_B	Input/Output	Wake-up	Open drain wake-up output. Designed to control a power supply enable pin. Input used to allow a wake-up from an external event.
29	25	38	INT_B	Input/Output	Interrupt	Open-drain output to MCU. Used to indicate an input switch change of state. Used as an input to allow wake-up from LPM via an external INT_B falling event.
30	26	39	AMUX	Output	Analog Multiplex Output	Analog multiplex output.
31	27	40	VDDQ	Input	Voltage Drain Supply	3.3 V/5.0 V supply. Sets SPI communication level for the MISO driver and I/O level buffer
32	28	41	MISO	Output/SPI	SPI Slave Out	Provides digital data from the 33978 to the MCU.
			EP	Ground	Exposed Pad	It is recommended that the exposed pad is terminated to GND (pin 1) and system ground.

# 4 General product characteristics

## 4.1 Maximum ratings

**Table 3. Maximum ratings**

All voltages are with respect to ground unless otherwise noted. Exceeding these ratings may cause a malfunction or permanent damage to the device.

Symbol	Description (rating)	Min.	Max.	Unit	Notes
<b>Electrical ratings</b>					
VBATP	Battery Voltage	-0.3	40	V	
VDDQ	Supply Voltage	-0.3	7.0	V	
CS_B, MOSI, MISO, SCLK	SPI Inputs/Outputs	-0.3	7.0	V	
SGx, SPx	Switch Input Range	-14 <sup>(4)</sup>	38	V	
AMUX	AMUX	-0.3	7.0	V	
INT_B	INT_B	-0.3	7.0	V	
WAKE_B	WAKE_B	-0.3	40	V	
V <sub>ESD1-2</sub> V <sub>ESD1-3</sub> V <sub>ESD3-1</sub> V <sub>ESD2-1</sub> V <sub>ESD2-2</sub>	ESD Voltage <ul style="list-style-type: none"> <li>Human Body Model (HBM) (VBATP versus GND) MC33978 and MC34978 MC33978A and MC34978A</li> <li>Human Body Model (HBM) (All other pins)</li> <li>Machine Model (MM)</li> <li>Charge Device Model (CDM) (Corners pins)</li> <li>Charge Device Model (CDM) (All other pins)</li> </ul>		±2000 ±4000 ±2000 ±200 ±750 ±500	V	(5)
V <sub>ESD5-3</sub> V <sub>ESD5-4</sub> V <sub>ESD6-1</sub> V <sub>ESD6-2</sub>	Contact Discharge <ul style="list-style-type: none"> <li>VBATP<sup>(8)</sup></li> <li>WAKE_B (series resistor 10 kΩ)</li> <li>SGx and SPx pins with 100 nF capacitor (100 Ω series R) based on external protection performance<sup>(7)</sup></li> <li>SGx and SPx pins with 100 nF capacitor (50 Ω series R)</li> </ul>		±8000 ±8000 ±15000 ±8000	V	(6)

**Notes**

- Minimum value of -18 V is guaranteed by design for switch input voltage range (SGx, SPx).
- ESD testing is performed in accordance AEC Q100, with the Human Body Model (HBM) ( $C_{ZAP} = 100 \text{ pF}$ ,  $R_{ZAP} = 1500 \text{ } \Omega$ ), the Machine Model (MM) ( $C_{ZAP} = 200 \text{ pF}$ ,  $R_{ZAP} = 0 \text{ } \Omega$ ), and the Charge Device Model (CDM).
- $C_{ZAP} = 330 \text{ pF}$ ,  $R_{ZAP} = 2.0 \text{ k}\Omega$  (Powered and unpowered) /  $C_{ZAP} = 150 \text{ pF}$ ,  $R_{ZAP} = 330 \text{ } \Omega$  (Unpowered)
- ±15000V capability in powered condition, ±8000V in all other conditions.
- External component requirements at system level:  
 $C_{bulk} = 100\mu\text{F}$  aluminum electrolytic capacitor  
 $C_{bypass} = 100\text{nF} \pm 37 \%$  ceramic capacitor  
 Reverse blocking diode from Battery to VBATP ( $0.6 \text{ V} < V_F < 1 \text{ V}$ ). See [Figure 24, Typical application diagram](#).

## 4.2 Thermal characteristics

**Table 4. Thermal ratings**

All voltages are with respect to ground unless otherwise noted. Exceeding these ratings may cause a malfunction or permanent damage to the device.

Symbol	Description (rating)	Min.	Max.	Unit	Notes
--------	----------------------	------	------	------	-------

### Thermal ratings

$T_A$ $T_J$	Operating Temperature • Ambient • Junction	-40 -40	125 150	°C	
$T_{STG}$	Storage Temperature	-65	150	°C	
$T_{PPRT}$	Peak Package Reflow Temperature During Reflow	–	–	°C	

### Thermal resistance

$R_{\theta JA}$	Junction-to-Ambient, Natural Convection, Single-Layer Board • 32 SOIC-EP • 32 QFN		79 94	°C/W	(9), (10)
$R_{\theta JB}$	Junction-to-Board • 32 SOIC-EP • 32 QFN		9.0 12	°C/W	(11)
$R_{\theta JC}$	Junction-to-Case (Bottom) • 32 SOIC-EP • 32 QFN		3.0 2.0	°C/W	(12)
$\Psi_{JT}$	Junction-to-Package (Top), Natural convection • 32 SOIC-EP • 32 QFN		11 2.0	°C/W	(13)

### Package dissipation ratings

$T_{SD}$	Thermal Shutdown • 32 SOIC-EP • 32 QFN	155	185	°C	
$T_{SDH}$	Thermal Shutdown Hysteresis • 32 SOIC-EP • 32 QFN	3.0	15	°C	

### Notes

9. Junction temperature is a function of die size, on-chip power dissipation, package thermal resistance, mounting site (board) temperature, ambient temperature, air flow, power dissipation of other components on the board, and board thermal resistance.
10. Per JEDEC JESD51-2 with natural convection for horizontally oriented board. Board meets JESD51-9 specification for 1s or 2s2p board, respectively.
11. Thermal resistance between the die and the printed circuit board per JEDEC JESD51-8. Board temperature is measured on the top surface of the board near the package.
12. Thermal resistance between the die and the solder pad on the bottom of the package based on simulation without any interface resistance.
13. Thermal characterization parameter indicating the temperature difference between package top and the junction temperature per JEDEC JESD51-2. When Greek letters are not available, the thermal characterization parameter is written as Psi-JT.



## 4.3 Operating conditions

This section describes the operating conditions of the device. Conditions apply to the following data, unless otherwise noted.

**Table 5. Operating conditions**

All voltages are with respect to ground unless otherwise noted. Exceeding these ratings may cause a malfunction or permanent damage to the device.

Symbol	Ratings	Min.	Max.	Unit	Notes
VBATP	Battery Voltage	4.5	36	V	
VDDQ	Supply Voltage	3.0	5.25	V	
CS_B, MOSI, MISO, SCLK	SPI Inputs / Outputs	3.0	5.25	V	
SGx, SPx	Switch Input Range	-1.0	36	V	
AMUX, INT_B	AMUX, INT_B	0.0	5.25	V	
WAKE_B	WAKE_B	0.0	36	V	

## 4.4 Electrical characteristics

### 4.4.1 Static electrical characteristics

**Table 6. Static electrical characteristics**

$T_A = -40\text{ }^{\circ}\text{C}$  to  $+125\text{ }^{\circ}\text{C}$ , VDDQ = 3.1 V to 5.25 V, VBATP = 6.0 V to 28.0 V, unless otherwise noted.

Symbol	Characteristic	Min.	Typ.	Max.	Units	Notes
<b>Power input</b>						
$V_{BATP(POR)}$	VBATP Supply Voltage POR • VBATP Supply Power on Reset voltage.	2.7	3.3	3.8	V	
$V_{BATPUV}$	VBATP Undervoltage Rising Threshold	—	4.3	4.5	V	
$V_{BATPUVHYS}$	VBATP Undervoltage Hysteresis	250	—	500	mV	
$V_{BATPOV}$	VBATP Overvoltage Rising Threshold	32	—	37	V	
$V_{BATPOVHYS}$	VBATP Overvoltage Hysteresis	1.5	—	3.0	V	
$I_{BAT(ON)}$	VBATP Supply Current • All switches open, Normal mode, Tri-state disabled (all channels)	—	7.0	12	mA	
$I_{BATP,IQ,LPM,P}$ $I_{BATP,IQ,LPM,F}$	VBATP Low-power Mode Supply Current (polling disabled) • Parametric $V_{BATP}$ , $6.0\text{ V} < V_{BATP} < 28\text{ V}$ • Functional Low $V_{BATP}$ , $4.5\text{ V} < V_{BATP} < 6.0\text{ V}$	— —	— —	40 40	$\mu\text{A}$	
$I_{POLLING,IQ}$	VBATP Polling Current • Polling 64 ms, 11 inputs of wake enabled	—	—	20	$\mu\text{A}$	(14)
$I_{VDDQ,NORMAL}$	Normal mode ( $I_{VDDQ}$ ) • SCLK, MOSI, WakeB = 0 V, CS_B, INT_B = $V_{DDQ}$ , no SPI communication, AMUX selected no input	—	—	500	$\mu\text{A}$	
$I_{VDDQ,LPM}$	Logic Low-power mode Supply Current • SCLK, MOSI = 0 V, CS_B, INT_B, WAKE_B = $V_{DDQ}$ , no SPI communication	—	—	10	$\mu\text{A}$	
$V_{GNDOFFSET}$	Ground Offset • Ground offset of Global pins to IC ground	-1.0	—	1.0	V	
$V_{DDQUV}$	VDDQ Undervoltage Falling Threshold	2.2	—	2.8	V	
$V_{DDQUVHYS}$	VDDQ Undervoltage Hysteresis	150	—	350	mV	

**Table 6. Static electrical characteristics (continued)**T<sub>A</sub> = - 40 °C to +125 °C, VDDQ = 3.1 V to 5.25 V, VBATP = 6.0 V to 28.0 V, unless otherwise noted.

Symbol	Characteristic	Min.	Typ.	Max.	Units	Notes
<b>Switch input</b>						
I <sub>LEAKSG_GND</sub>	Leakage (SGx/SPx pins) to GND • Inputs tri-stated, analog mux selected for each input, voltage at SGx = VBATP	—	—	2.0	μA	
I <sub>LEAKSG_BAT</sub>	Leakage (SGx/SPx pins) to Battery • Inputs tri-stated, analog mux selected for each input, voltage at SGx = GND	—	—	2.0	μA	
I <sub>SUSSG</sub>	SG Sustain current / Mode 0 Wetting current • VBATP 6.0 to 28 V	1.6	2.0	2.4	mA	
I <sub>SUSSGLV</sub>	SG Sustain current / Mode 0 Wetting current LV • VBATP 4.5 V to 6.0 V	1.0	—	2.4	mA	(15)
I <sub>SUSSB</sub>	SB Sustain current / Mode 0 Wetting current	1.75	2.2	2.85	mA	
I <sub>WET</sub>	Wetting current level (SG & SB) • Mode 1 = 6mA • Mode 2 = 8mA • Mode 3 = 10mA • Mode 4 = 12mA • Mode 5 = 14mA • Mode 6 = 16mA • Mode 7 = 20mA	—	6 8 10 12 14 16 20	—	mA	
I <sub>WETSG</sub>	SG wetting current tolerance • Mode 1 to 7	-10	—	10	%	
I <sub>WETSGLV</sub>	SG wetting current tolerance LV (VBATP 4.5 to 6.0V) <sup>(15)</sup> • Mode 1 = 6mA • Mode 2 = 8mA • Mode 3 = 10mA • Mode 4 = 12mA • Mode 5 = 14mA • Mode 6 = 16mA • Mode 7 = 20mA	2.0 2.0 2.0 2.0 2.0 2.0 2.0	— — — — — — —	6.6 8.8 11.0 13.2 15.4 17.6 22.0	mA	
I <sub>WETSB</sub>	SB wetting current tolerance • Mode 1 to 7	-20	—	20	%	
I <sub>MATCH(SUS)</sub>	Sustain Current Matching Between Channels	—	—	10	%	(16), (17)
I <sub>MATCH(WET)</sub>	Wetting Current Matching Between Channels	—	—	6.0	%	(18), (19)
V <sub>ICTHR</sub>	Switch Detection Threshold	3.7	4.0	4.3	V	(20)
V <sub>ICTHRLV</sub>	Switch Detection Threshold Low Battery • VBATP 4.5 V to 6.0 V	0.55 * V <sub>BATP</sub>	—	4.3	V	
V <sub>ICTHRLPM</sub>	Switch Detection Threshold Low-power Mode (SG only)	100	—	300	mV	(21)
V <sub>ICTHRH</sub>	Switch Detection Threshold Hysteresis (4.0 V threshold)	80	—	300	mV	
V <sub>ICTH2P5</sub>	Input Threshold 2.5 V, • Used for Comp Only and for AMUX Hardwired Select (SG1/2/3)	2.0	2.5	3.0	V	
I <sub>ACTIVEPOLLSG</sub>	Low-power Mode Polling Current SG • VBATP 4.5 V to 28 V	0.7	1.0	1.44	mA	
I <sub>ACTIVEPOLLSB</sub>	Low-power Mode Polling Current SB	1.75	2.2	2.85	mA	

**Table 6. Static electrical characteristics (continued)**

$T_A = -40\text{ }^\circ\text{C}$  to  $+125\text{ }^\circ\text{C}$ ,  $V_{DDQ} = 3.1\text{ V}$  to  $5.25\text{ V}$ ,  $V_{BATP} = 6.0\text{ V}$  to  $28.0\text{ V}$ , unless otherwise noted.

Symbol	Characteristic	Min.	Typ.	Max.	Units	Notes
<b>Digital interface</b>						
$I_{HZ}$	Tri-state Leakage Current (MISO) • $V_{DDQ} = 0.0$ to $V_{DDQ}$	-2.0	—	2.0	$\mu\text{A}$	
$V_{INLOGIC}$	Input Logic Voltage Thresholds • SI, SCLK, CS_B, INT_B	$V_{DDQ} * 0.25$	—	$V_{DDQ} * 0.7$	V	
$V_{INLOGICHYS}$	Input Logic Hysteresis • SI, SCLK, CS_B, INT_B	300	—	—	mV	
$V_{INLOGICWAKE}$	Input Logic Voltage Threshold WAKE_B	0.8	1.25	1.7	V	
$V_{INWAKEBHYS}$	Input Logic Voltage Hysteresis WAKE_B	200	—	800	mV	
$I_{SCLK}, I_{MOSI}$	SCLK / MOSI Input Current • SCLK / MOSI = 0 V	-3.0	—	3.0	$\mu\text{A}$	
$I_{SCLK}, I_{MOSI}$	SCLK / MOSI Pull-down Current • SCLK / MOSI = $V_{DDQ}$	30	—	100	$\mu\text{A}$	
$I_{CS\_BH}$	CS_B Input Current • CS_B = $V_{DDQ}$	-10	—	10	$\mu\text{A}$	
$R_{CS\_BL}$	CS_B Pull-up Resistor to $V_{DDQ}$ • CS_B = 0.0 V	40	125	270	$\text{k}\Omega$	
$V_{OHMISO}$	MISO High-side Output Voltage • $I_{OHMISO} = -1.0\text{ mA}$	$V_{DDQ} - 0.8$	—	$V_{DDQ}$	V	
$V_{OLMISO}$	MISO Low-side Output Voltage • $I_{OLMISO} = 1.0\text{ mA}$	—	—	0.4	V	
$C_{IN}$	Input Capacitance on SCLK, MOSI, Tri-state MISO (GBD)	—	—	20	pF	
<b>Analog MUX output</b>						
$V_{OFFSET}$	Input Offset Voltage When Selected as Analog • EK suffix (SOICW) • ES suffix (QFN at $T_A = -40\text{ }^\circ\text{C}$ to $25\text{ }^\circ\text{C}$ )	-10 -15	— —	10 15	mV	(22)
$V_{OLAMUX}$	Analog Operational Amplifier Output Voltage • Sink 1.0 mA	—	—	50	mV	
$V_{OHAMUX}$	Analog Operational Amplifier Output Voltage • Source 1.0 mA	$V_{DDQ} - 0.1$	—	—	V	
<b>AMUX selectable outputs</b>						
Temp-Coeff	Chip Temperature Sensor Coefficient	—	8.0	—	$\text{mV}/^\circ\text{C}$	
$V_{BATSNSACC}$	Battery Sense (SG5 config) Accuracy • Battery voltage (SG5 input) divided by 6 • Accuracy over full temperature range	-5.0	—	5.0	%	
$V_{BATSNSDIV}$	Divider By 6 coefficient accuracy • Offset over operating voltage range ( $V_{BATP}=6.0\text{ V}$ to $28\text{ V}$ )	-3.0	—	3.0	%	(23)

**Table 6. Static electrical characteristics (continued)**

$T_A = -40\text{ }^\circ\text{C}$  to  $+125\text{ }^\circ\text{C}$ ,  $V_{DDQ} = 3.1\text{ V}$  to  $5.25\text{ V}$ ,  $V_{BATP} = 6.0\text{ V}$  to  $28.0\text{ V}$ , unless otherwise noted.

Symbol	Characteristic	Min.	Typ.	Max.	Units	Notes
<b>INT_B</b>						
$V_{OLINT}$	INT_B Output Low Voltage • $I_{OUT} = 1.0\text{ mA}$	—	0.2	0.5	V	
$V_{OHINT}$	INT_B Output High Voltage • INT_B = Open-circuit	$V_{DDQ} - 0.5$	—	$V_{DDQ}$	V	
$R_{PU}$	Pull-up Resistor to $V_{DDQ}$	40	125	270	$k\Omega$	
$I_{LEAKINT\_B}$	Leakage Current INT_B • INT_B pulled up to $V_{DDQ}$	—	—	1.0	$\mu\text{A}$	

**Temperature limit**

$t_{FLAG}$	Temperature Warning • First flag to trip	105	120	135	$^\circ\text{C}$	
$t_{LIM}$	Temperature Monitor	155	—	185	$^\circ\text{C}$	(24)
$t_{LIM(HYS)}$	Temperature Monitor Hysteresis	5.0	—	15	$^\circ\text{C}$	(24)

**WAKE\_B**

$R_{WAKE\_B(RPU)}$	WAKE_B Internal pull-up Resistor to $V_{DDQ}$	40	125	270	$k\Omega$	
$V_{WAKE\_B(VOH)}$	WAKE_B Voltage High • WAKE_B = Open-circuit	$V_{DDQ} - 1.0$	—	$V_{DDQ}$	V	
$V_{WAKE\_B(VOL)}$	WAKE_B Voltage Low • WAKE_B = 1.0 mA ( $R_{PU}$ to $V_{BATP} = 16\text{ V}$ )	—	—	0.4	V	
$I_{WAKE\_BLEAK}$	WAKE_B Leakage • WAKE_B pulled up to $V_{BATP} = 16\text{ V}$ through $10\text{ k}\Omega$	—	—	1.0	$\mu\text{A}$	

**Notes**

14. Guaranteed by design
15. During low voltage range operation SG wetting current may be limited when there is not enough headroom between  $V_{BATP}$  and SG pin voltage.
16.  $(I_{SUS(MAX)} - I_{SUS(MIN)}) \times 100 / I_{SUS(MIN)}$
17. Sustain current source (SGs only)
18.  $(I_{WET(MAX)} - I_{WET(MIN)}) \times 100 / I_{WET(MIN)}$
19. Wetting current source (SGs only)
20. The input comparator threshold decreases when  $V_{BATP} \leq 6.0\text{ V}$ .
21. SP (as SB) only use the  $4.0\text{ V } V_{ICTHR}$  for LPM wake-up detection.
22. For applications requiring a tight AMUX offset through the whole operating range, it is recommended to use the MC33978AEK or MC34978AEK (SOICW package) variant.
23. Calibration of divider ratio can be done at  $V_{BAT} = 12\text{ V}$ ,  $25\text{ }^\circ\text{C}$  to achieve a higher accuracy. See [Figure 5](#) for AMUX offset linearity waveform through the operating voltage range.
24. Guaranteed by characterization in the Development Phase, parameter not tested.

## 4.4.2 Dynamic electrical characteristics

**Table 7. Dynamic electrical characteristics**

$T_A = -40\text{ }^\circ\text{C}$  to  $+125\text{ }^\circ\text{C}$ . VDDQ = 3.1 V to 5.25 V, VBATP = 6.0 V to 28 V, unless otherwise specified. All SPI timing is performed with a 100 pF load on MISO, unless otherwise noted.

Symbol	Parameter	Min.	Typ.	Max.	Units	Notes
<b>General</b>						
$t_{\text{ACTIVE}}$	POR to Active time • Undervoltage to Normal mode	250	340	450	$\mu\text{s}$	
<b>Switch input</b>						
$t_{\text{PULSE(ON)}}$	Pulse Wetting Current Timer • Normal mode	17	20	23	ms	
$t_{\text{INT-DLY}}$	Interrupt Delay Time • Normal mode	—	—	18.5	$\mu\text{s}$	
$t_{\text{POLLING\_TIMER}}$	Polling Timer Accuracy • Low-power mode	—	—	15	%	
$t_{\text{INT-TIMER}}$	Interrupt Timer Accuracy • Low-power mode	—	—	15	%	
$t_{\text{ACTIVEPOLLSGT}}^{\text{IME}}$	Tactivepoll Timer SG	49.5	58	66.5	$\mu\text{s}$	
$t_{\text{ACTIVEPOLLSBT}}^{\text{IME}}$	Tactivepoll Timer SB • SBPOLLTIME=0 • SBPOLLTIME=1	1.0 49.5	1.2 58	1.4 66.5	ms $\mu\text{s}$	
$t_{\text{GLITCHTIMER}}$	Input Glitch Filter Timer • Normal mode	5.0	—	18	$\mu\text{s}$	
$t_{\text{DEBOUNCE}}$	LPM Debounce Additional Time • Low-power mode	1.0	1.2	1.4	ms	
<b>AMUX output</b>						
AMUX <sub>VALID</sub>	AMUX Access Time (Selected Output to Selected Output) • $C_{\text{MUX}} = 1.0\text{ nF}$ , Rising edge of CS_B to selected	—	(26)	—	$\mu\text{s}$	
AMUX <sub>VALIDTS</sub>	AMUX Access Time (Tristate to ON) • $C_{\text{MUX}} = 1.0\text{ nF}$ , Rising edge of CS_B to selected	—	—	20	$\mu\text{s}$	
<b>Oscillator</b>						
OSC <sub>TOLLPM</sub>	Oscillator Tolerance at 192 kHz in Low-power Mode	-15	—	15	%	
OSC <sub>TOLNOR</sub>	Oscillator Tolerance Normal Mode at 4.0 MHz	-15	—	15	%	
<b>Interrupt</b>						
INT <sub>PULSE</sub>	INT Pulse Duration • Interrupt occurs or INT_B request	90	100	110	$\mu\text{s}$	
<b>SPI interface</b>						
$f_{\text{OP}}$	Transfer Frequency	—	—	8.0	MHz	
$t_{\text{SCK}}$	SCLK Period • <a href="#">Figure 8 - 1</a>	160	—	—	ns	
$t_{\text{LEAD}}$	Enable Lead Time • <a href="#">Figure 8 - 2</a>	140	—	—	ns	
$t_{\text{LAG}}$	Enable Lag Time • <a href="#">Figure 8 - 3</a>	50	—	—	ns	
$t_{\text{SCKHS}}$	SCLK High Time • <a href="#">Figure 8 - 4</a>	56	—	—	ns	

**Table 7. Dynamic electrical characteristics (continued)**

$T_A = -40\text{ }^\circ\text{C}$  to  $+125\text{ }^\circ\text{C}$ .  $V_{DDQ} = 3.1\text{ V}$  to  $5.25\text{ V}$ ,  $V_{BATP} = 6.0\text{ V}$  to  $28\text{ V}$ , unless otherwise specified. All SPI timing is performed with a  $100\text{ pF}$  load on MISO, unless otherwise noted.

Symbol	Parameter	Min.	Typ.	Max.	Units	Notes
<b>SPI interface (continued)</b>						
$t_{SCKLS}$	SCLK Low Time • <a href="#">Figure 8 - 5</a>	56	—	—	ns	
$t_{SUS}$	MOSI Input Setup Time • <a href="#">Figure 8 - 6</a>	16	—	—	ns	
$t_{HS}$	MOSI Input Hold Time • <a href="#">Figure 8 - 7</a>	20	—	—	ns	
$t_A$	MISO Access Time • <a href="#">Figure 8 - 8</a>	—	—	116	ns	
$t_{DIS}$	MISO Disable Time <sup>(25)</sup> • <a href="#">Figure 8 - 9</a>	—	—	100	ns	
$t_{VS}$	MISO Output Valid Time • <a href="#">Figure 8 - 10</a>	—	—	116	ns	
$t_{HO}$	MISO Output Hold Time (No cap on MISO) • <a href="#">Figure 8 - 11</a>	20	—	—	ns	
$t_{RO}$	Rise Time • <a href="#">Figure 8 - 12</a>	—	—	30	ns	(25)
$t_{FO}$	Fall Time • <a href="#">Figure 8 - 13</a>	—	—	30	ns	(25)
$t_{CSN}$	CS_B Negated Time • <a href="#">Figure 8 - 14</a>	500	—	—	ns	
<b>WAKE-UP</b>						
$t_{CSB\_WAKEUP}$	LPM mode wake-up time triggered by edge of CS_B	—	755	1000	$\mu\text{s}$	(27)

**Notes**

25. Guaranteed by characterization.
26. AMUX settling time to be within the 10 mV offset specification.  $AMUX_{VALID}$  is dependent of the voltage step applied on the input SGx/SPx pin or the difference between the first and second channel selected as the multiplexed analog output. See [Figure 10](#) for a typical AMUX access time VS voltage step waveform.
27. The parameter is guaranteed at  $V_{BATP} = 4.5\text{ V}$  to  $28\text{ V}$ .

## Divide By 6 Coefficient Accuracy

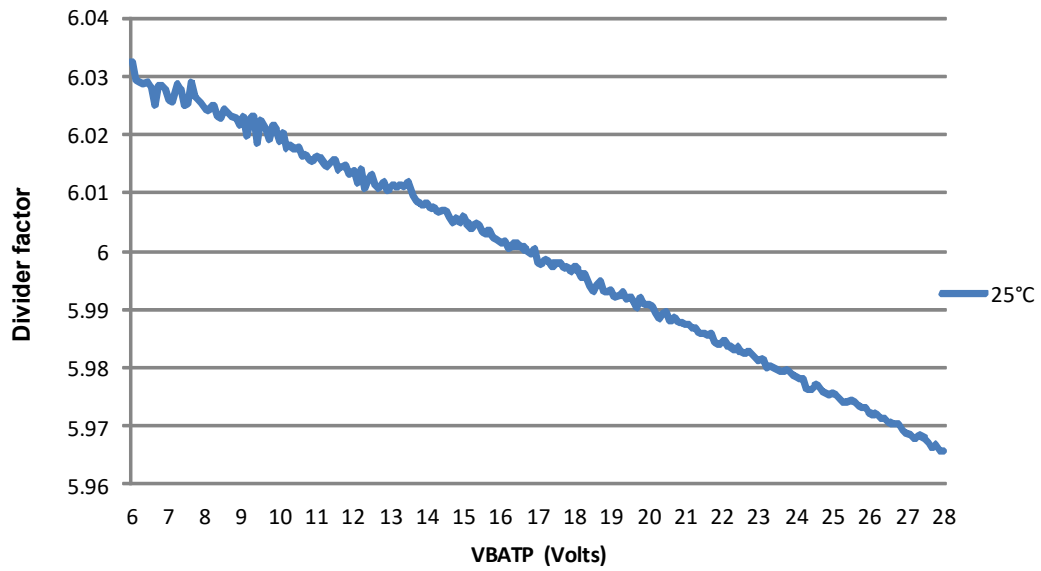

Figure 5. Divide by 6 coefficient accuracy

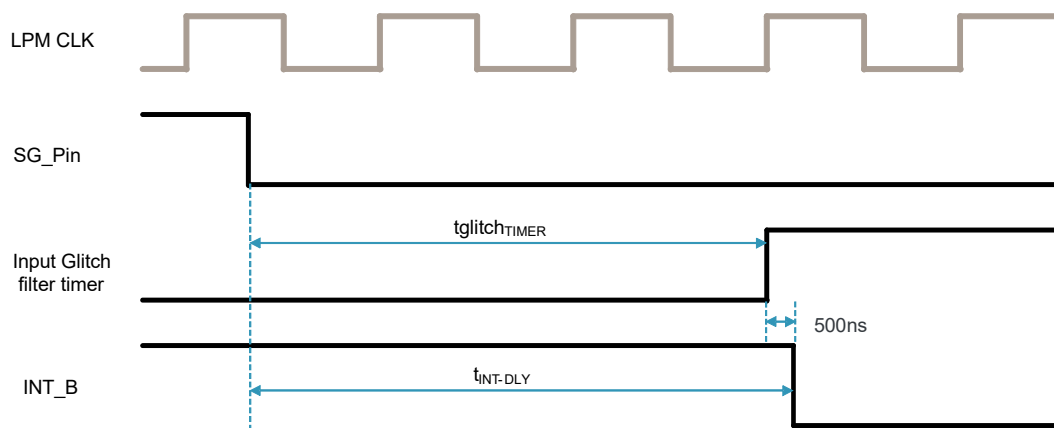

Figure 6. Glitch filter and interrupt delay timers

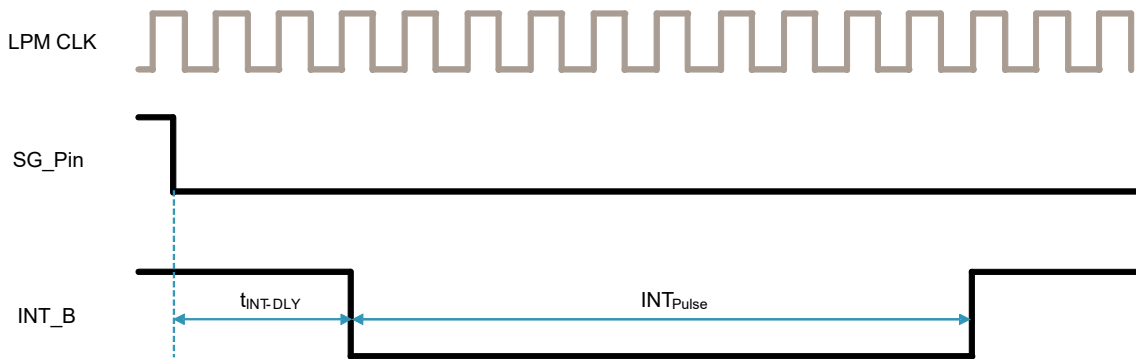

Figure 7. Interrupt pulse timer

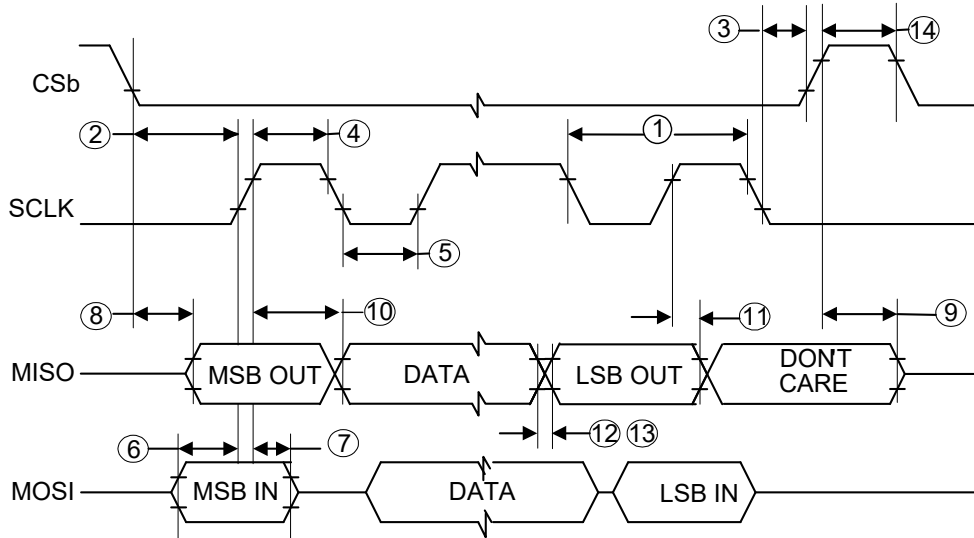

Figure 8. SPI timing diagram

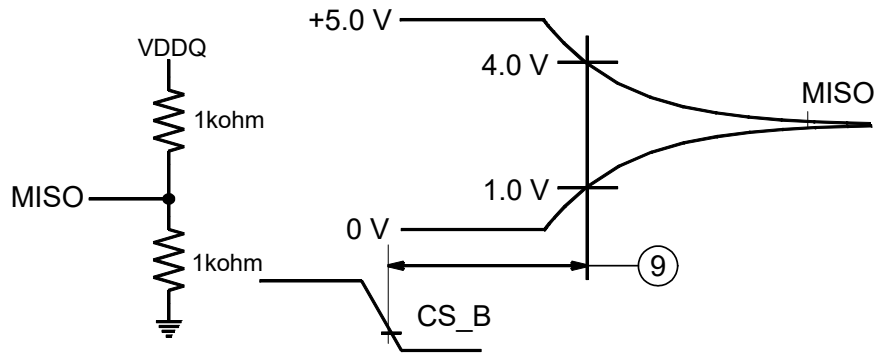

Figure 9. MISO loading for disable time measurement

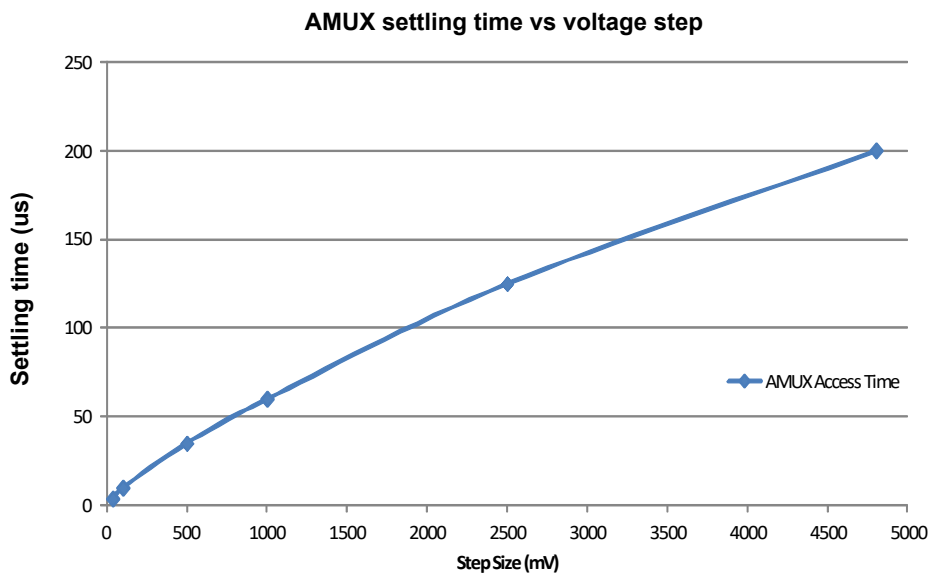

Figure 10. AMUX access time waveform



# 5 General description

The 33978 is designed to detect the closing and opening of up to 22 switch contacts. The switch status, either open or closed, is transferred to the microprocessor unit (MCU) through a serial peripheral interface (SPI). Individually selectable input currents are available in Normal and Low-power (LPM) modes, as needed for the application.

It also features a 24-to-1 analog multiplexer for reading inputs as analog. The analog input signal is buffered and provided on the AMUX output pin for the MCU to read. A battery and temperature monitor are included in the IC and available via the AMUX pin.

The 33978 device has two modes of operation, Normal and Low-power mode (LPM). Normal mode allows programming of the device and supplies switch contacts with pull-up or pull-down current as it monitors the change of state of switches. The LPM provides low quiescent current, which makes the 33978 ideal for automotive and industrial products requiring low sleep-state currents.

## 5.1 Features

- Fully functional operation from 4.5 V to 36 V
- Full parametric operation from 6.0 V to 28 V
- Low-power mode current  $I_{BATP} = 30 \mu\text{A}$  and  $I_{DDQ} = 10 \mu\text{A}$
- 22 Switch detection channels
  - 14 Switch-to-Ground (SG) inputs
  - Eight Programmable switch (SP) inputs
    - Switch-to-Ground (SG) or Switch-to-Battery (SB)
  - Operating switch input voltage range from -1.0 V to 36 V
  - Selectable wetting current (2, 6, 8, 10, 12, 14, 16, or 20 mA)
  - Programmable wetting operation (Pulse or Continuous)
  - Selectable wake-up on change of state
- 24 to 1 Analog Multiplexer
  - Buffered AMUX output from SG/SP channels
  - Integrated divider by 6 on SG5 for battery voltage sensing
  - Integrated die temperature sensing through AMUX output
  - Two or three pin hardwire AMUX selection.
- Active interrupt (INT\_B) on change-of-switch state
- Direct MCU Interface through 3.3 V / 5.0 V SPI protocol

## 5.2 Functional block diagram

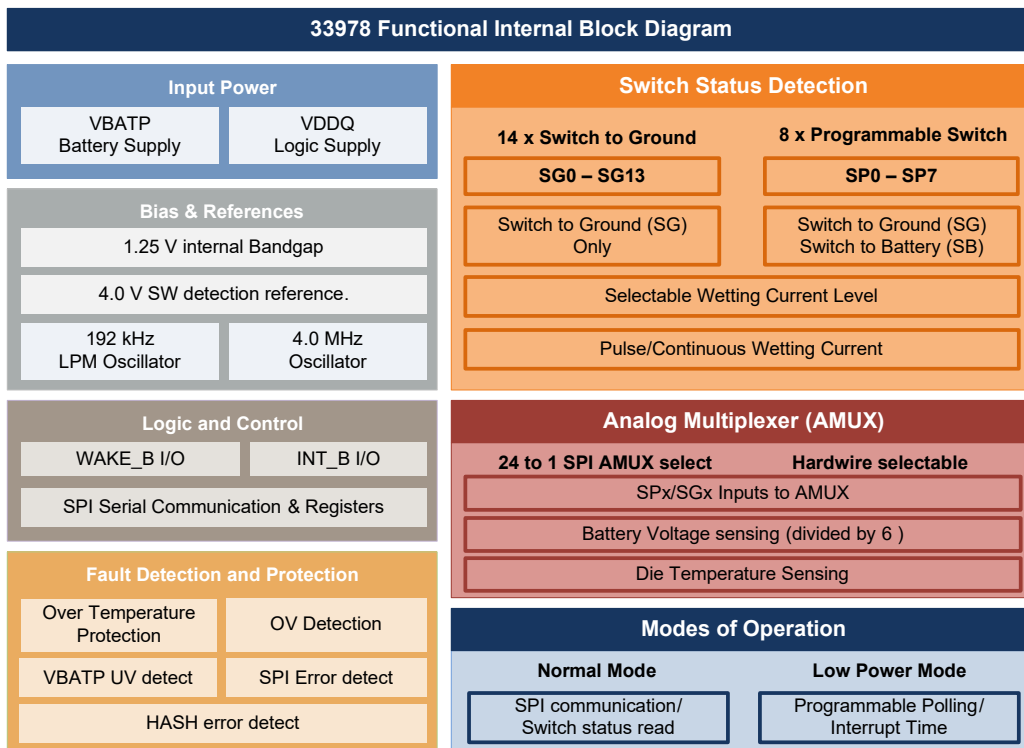

Figure 11. Functional block diagram

## 6 General IC functional description

The 33978 device interacts with many connections outside the module and near the end user. The IC detects changes in switch state and reports the information to the MCU via the SPI protocol. The input pins generally connected to switches located outside the module and in proximity to battery in car harnesses. Consequently, the IC must have some external protection including an ESD capacitor and series resistors, to ensure the energy from the various pulses are limited at the IC.

The IC requires a blocking diode be used on the VBATP pin to protect from a reverse battery condition. The inputs are capable of surviving reverse battery without a blocking diode and also contain an internal blocking diode from the input to the power supply ( $V_{BATP}$ ), to ensure there is no backfeeding of voltage/current into the IC, when the voltage on the input is higher than the VBATP pin.

### 6.1 Battery voltage ranges

The 33978 device operates from  $4.5\text{ V} \leq V_{BATP} \leq 36\text{ V}$  and is capable to withstand up to 40 V. The IC operates functionally from  $4.5\text{ V} < V_{BATP} < 6.0\text{ V}$ , but with degraded parametrics values. Voltages in excess of 40 V must be clamped externally in order to protect the IC from destruction. The VBATP pin must be isolated from the main battery node by a diode.

#### 6.1.1 Load dump (overvoltage)

During load dump the 33978 operates properly up to the  $V_{BATP}$  overvoltage. Voltages greater than load dump (~32 V) causes the current sources to be limited to ~2.0 mA, but the register values are maintained. Upon leaving this overvoltage condition, the original setup is returned and normal operation begins again.

#### 6.1.2 Jump start (double battery)

During a jump start (double battery) condition, the device functions normally and meets all the specified parametric values. No internal faults are set and no abnormal operation noted as a result of operating in this range.

#### 6.1.3 Normal battery range

The normal voltage range is fully functional with all parametrics in the given specification.

#### 6.1.4 Low-voltage range (degraded parametrics)

In the  $V_{BATP}$  range between 4.5 V to 6.0 V the 33978 functions normally, but has some degraded parametric values. The SPI functions normally with no false reporting. The degraded parameters are noted in [Table 6](#) and [Table 7](#). During this condition, the input comparator threshold is reduced from 4.0 V and remain ratiometrically adjusted, according to the battery level.

#### 6.1.5 Undervoltage lockout

During undervoltage lockout, the MISO output is tri-stated to avoid any data from being transmitted from the 33978. Any CS\_B pulses are ignored in this voltage range. If the battery enters this range at any point (even during a SPI word), the 33978 ignores the word and enters lockout mode. A SPI bit register is available to notify the MCU that the 33978 has seen an undervoltage lockout condition once the battery is high enough to leave this range.

#### 6.1.6 Power on reset (POR) activated

The Power on Reset is activated when the VBATP is within the 2.7 V to 3.8 V range. During the POR all SPI registers are reset to default values and SPI operation is disabled. The 33978 is initialized after the POR is de-asserted. A SPI bit in the device configuration register is used to note a POR occurrence and all SPI registers are reset to the default values.

#### 6.1.7 No operation

The device does not function and no switch detection is possible.

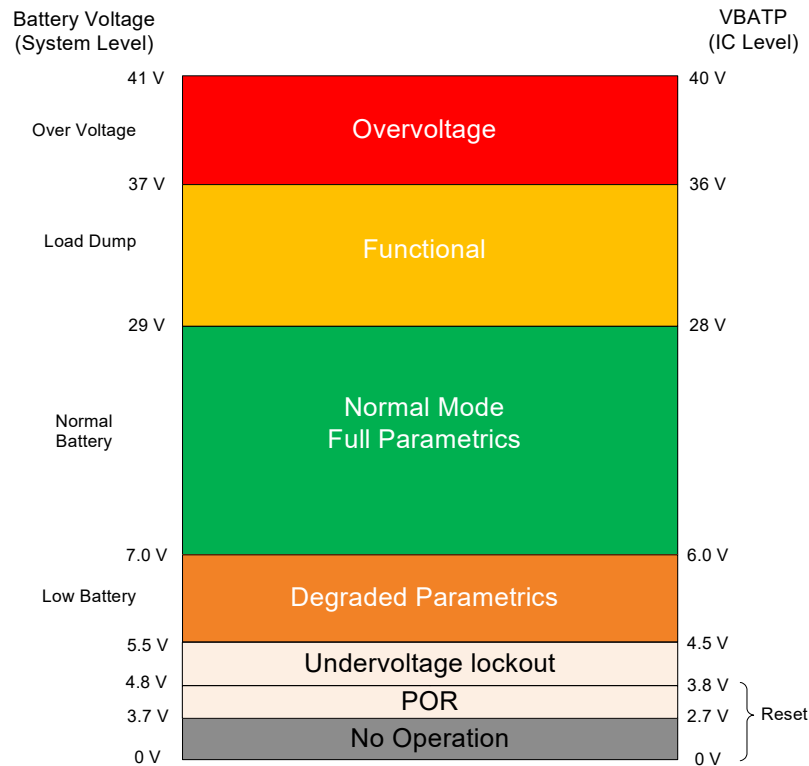

Figure 12. Battery voltage range

## 6.2 Power sequencing conditions

The chip uses two supplies as inputs into the device for various usage. The pins are VBATP and VDDQ. The VBATP pin is the power supply for the chip where the internal supplies are generated and power supply for the SG circuits. The VDDQ pin is used for the I/O buffer supply to talk to the MCU or other logic level devices, as well as AMUX. The INT\_B pin is held low upon POR until the IC is ready to operate and communicate. Power can be applied in various ways to the 33978 and the following states are possible:

### 6.2.1 $V_{BATP}$ before $V_{DDQ}$

The normal condition for operation is the application of  $V_{BATP}$  and then  $V_{DDQ}$ . The chip begins to operate logically in the default state but without the ability to drive logic pins. When the  $V_{DDQ}$  supply is available the chip is able to communicate correctly. The IC maintains its logical state (register settings) with functional behavior consistent with logical state. No SPI communications can occur.

### 6.2.2 $V_{DDQ}$ before $V_{BATP}$

The  $V_{DDQ}$  supply in some cases may be available before the  $V_{BATP}$  supply is ready. In this scenario, there is no back feeding current into the VDDQ pin that could potentially turn on the device into an unknown state. VDDQ is isolated from VBATP circuits and the device is off until VBATP is applied; when  $V_{BATP}$  is available the device powers up the internal rails and logic within  $t_{ACTIVE}$  time. Communication is undefined until the  $t_{ACTIVE}$  time and becomes available after this time frame.

### 6.2.3 $V_{BATP}$ okay, $V_{DDQ}$ lost

After power up, it is possible that the  $V_{DDQ}$  may turn off or be lost. In this case, the chip remains in the current state but is not able to communicate. After the VDDQ pin is available again, the chip is ready to communicate.

### 6.2.4 $V_{DDQ}$ okay, $V_{BATP}$ lost

After power up, the  $V_{BATP}$  supply could be lost. The operation is consistent as when  $V_{DDQ}$  is available before  $V_{BATP}$ .

# 7 Functional block description

## 7.1 State diagram

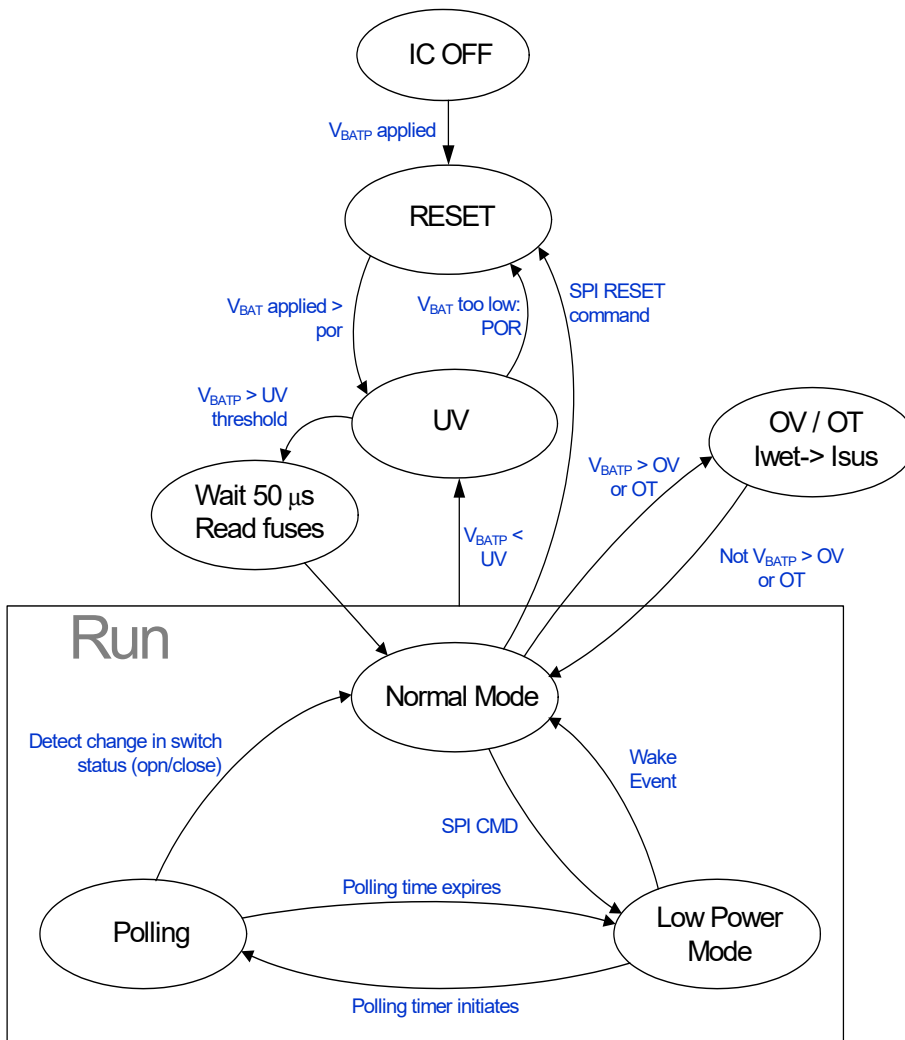

Figure 13. 33978 state diagram

### 7.1.1 State machine

After power up, the IC enters into the device state machine, as illustrated in [Figure 13](#). The voltage on VBATP begins to power the internal oscillators and regulator supplies. The POR is based on the internal 2.5 V digital core rail. When the internal logic regulator reaches approximately 1.8 V (typically 3.3 V on the VBATP node), the IC enters into the UV range. Below the POR threshold, the IC is in RESET mode where no activity occurs.

## 7.1.2 UV: undervoltage lockout

After the POR circuit has reset the logic, the IC is in undervoltage. In this state, the IC remembers all register conditions, but is in a lockout mode, where no SPI communication is allowed. The AMUX is inactive and the current sources are off. The user does not receive a valid response from the MISO, as it is disabled in this state. The chip oscillators (4.0 MHz for most normal mode activities, 192 kHz for LPM, and limited normal mode functions) are turned on in the UV state. The chip moves to the Read fuses state when the  $V_{BATP}$  voltage rises above the UV threshold (~4.3 V rising). The internal fuses read in approximately 50  $\mu$ s and the chip enters the Normal mode.

## 7.1.3 Normal mode

In normal mode, the chip operates as selected in the available registers. Any command may be loaded in normal mode, although not all (Low-power mode) registers are used in the Normal mode. All the LPM registers must be programmed in Normal mode as the SPI is not active in LPM. The Normal mode of the chip is used to operate the AMUX, communicate via the SPI, Interrupt the IC, wetting and sustain currents, as well as the thresholds available to use. The WAKE\_B pin is asserted (low) in Normal mode and can be used to enable a power supply (ENABLE\_B). Various fault detections are available in this mode including overvoltage, overtemperature, thermal warning, SPI errors, and Hash faults.

## 7.1.4 Low-power mode

When the user needs to lower the IC current consumption, a low-power mode is used. The only method to enter LPM is through a SPI word. After the chip is in low-power mode, the majority of circuitry is turned off including most power rails, the 4.0 MHz oscillator, and all the fault detection circuits. This mode is the lowest current consumption mode on the chip. If a fault occurs while the chip is in this mode, the chip does not see or register the fault (does not report via the SPI when awakened). Some items may wake the IC in this mode, including the interrupt timer, falling edge of INT\_B, CS\_B, or WAKE\_B (configurable), or a comparator only mode switch detection.

## 7.1.5 Polling mode

The 33978 uses a polling mode which periodically (selectable in LPM config register) interrogates the input pins to determine in what state the pins are, and decide if there was a change of state from when the chip was in Normal mode. There are various configurations for this mode, which allow the user greater flexibility in operation. This mode uses the current sources to pull-up (SG) or down (SB) to determine if a switch is open or closed. More information is available in section 7.2, "Low-power mode operation".

In the case of a low  $V_{BATP}$ , the polling pauses and waits until the  $V_{BATP}$  rises out of UV or a POR occurs. The pause of the polling ensures all of the internal rails, currents, and thresholds are up at the required levels to accurately detect open or closed switches. The chip does not wake-up in this condition and simply waits for the  $V_{BATP}$  voltage to rise or cause a POR.

After the polling ends, the chip either returns to the low-power mode, or enters Normal mode when a wake event was detected. Other events may wake the chip as well, such as the falling edge of CS\_B, INT\_B, or WAKE\_B (configurable). A comparator only mode switch detection is always on in LPM or Polling mode, so a change of state for those inputs would effectively wake the IC in Polling mode as well. If the Wake-up enable bits are disable on all channels (SG and SP) the device will not wake up with a change of state on any of the input pins; in this case, the device will disable the polling timer to allow the lowest current consumption during low-power mode.

## 7.2 Low-power mode operation

Low-power mode (LPM) is used to reduce system quiescent currents. LPM may be entered only by sending the Enter Low-power mode command. All register settings programmed in Normal mode are maintained while in LPM.

The 33978 exits LPM and enter Normal mode when any of the following events occur:

- Input switch change of state (when enabled)
- Interrupt timer expire
- Falling edge of WAKE\_B (as set by the device configuration register)
- Falling edge of INT\_B (with  $V_{DDQ} = 5.0$  V)
- Falling edge of CS\_B (with  $V_{DDQ} = 5.0$  V)
- Power-ON Reset (POR)

The  $V_{DDQ}$  supply may be removed from the device during LPM, however removing  $V_{DDQ}$  from the device disables a wake-up from falling edge of INT\_B and CS\_B. The IC checks the status of  $V_{DDQ}$  after a falling edge of WAKE\_B (as selected in the device configuration register), INT\_B and CS\_B. The IC returns to LPM and does not report a Wake event, if  $V_{DDQ}$  is low. If the  $V_{DDQ}$  is high, the IC wakes up and reports the Wake event. In cases where CS\_B is used to wake the device, the first MISO data message is not valid.

The LPM command contains settings for two programmable registers: the interrupt timer and the polling timer, as shown in [Table 26](#). The interrupt timer is used as a periodic wake-up timer. When the timer expires, an interrupt is generated and the device enters Normal mode. The polling timer is used periodically to poll the inputs during Low-power mode to check for change of states. The  $t_{ACTIVEPOLL}$  time is the length of time the part is active during the polling timer to check for change of state. The Low-power mode voltage threshold allows the user to determine the noise immunity versus lower current levels that polling allows. [Figure 15](#) shows the polling operation.

When polling and Interrupt timer coincide, the Interrupt timer wakes the device and the polling does not occur. When an input is determined to meet the condition Open (when entering LPM), yet while Open (on polling event) the chip does not continue the polling event for that input(s) to lower current in the chip ([Figure 14](#) shows SG, SB is logically the same).

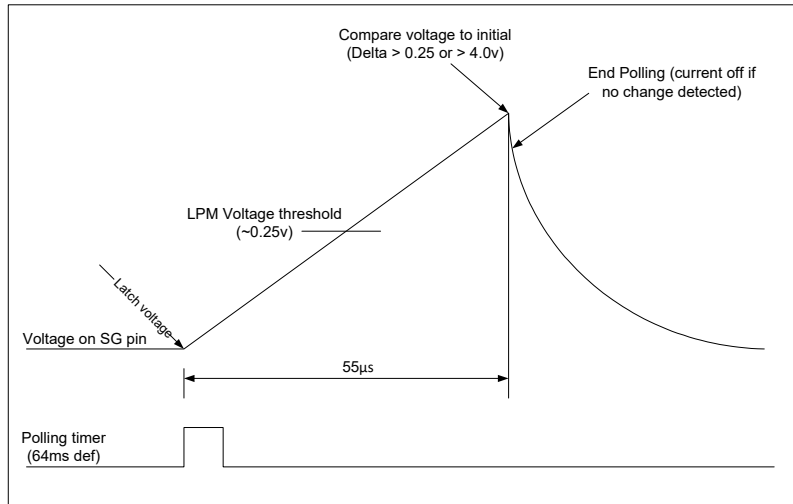

**Figure 14. Low-power mode polling check**

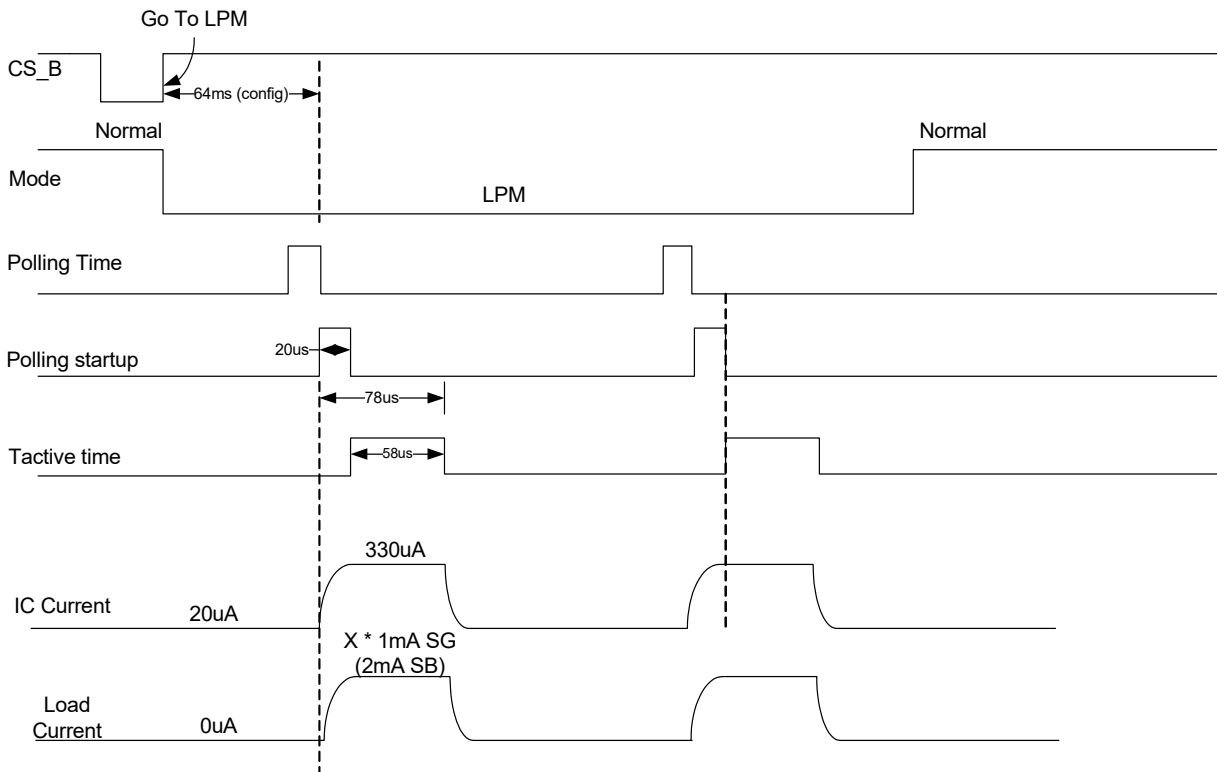

**Figure 15. Low-power mode typical timing**

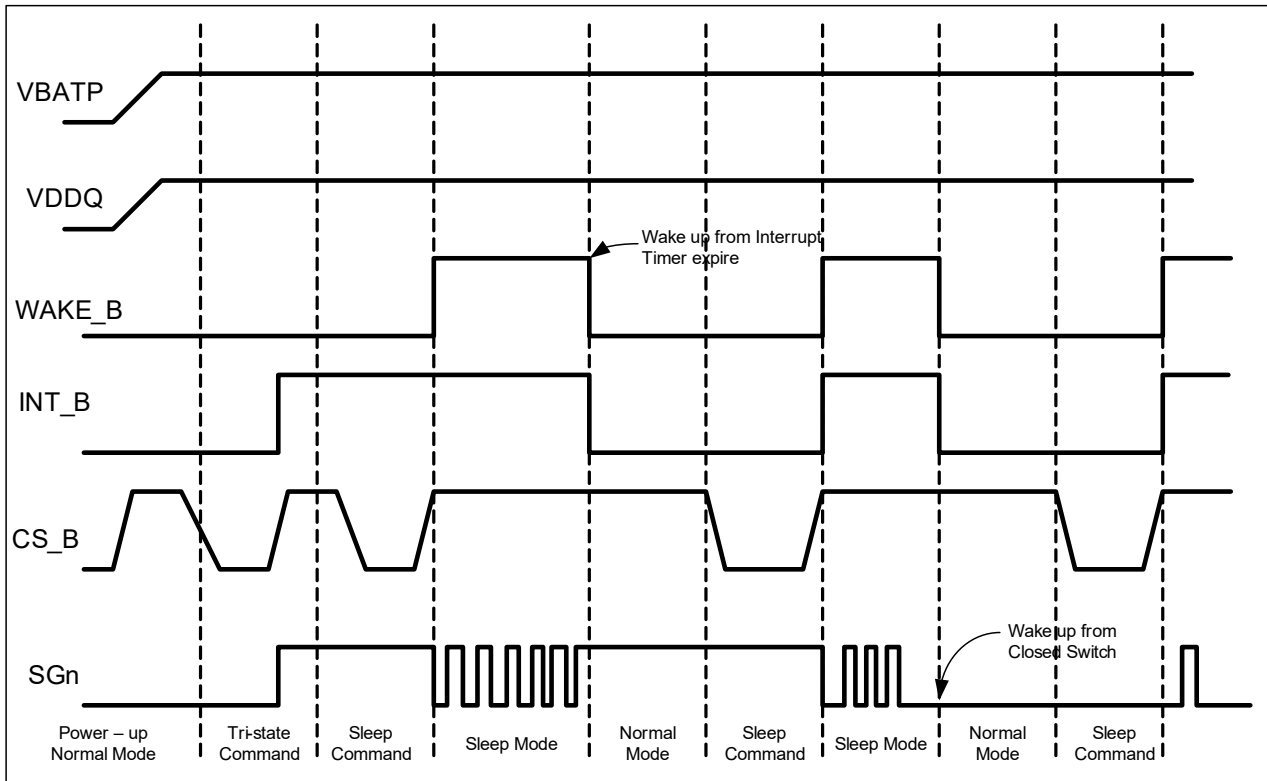

Figure 16. Low-power mode to normal mode operation

### 7.3 Input functional block

The SGx pins are switch-to-ground inputs only (pull-up current sources).

The SPx pins are configurable as either switch to ground or switch to battery (pull-up and pull-down current sources).

The input is compared with a 4.0 V (input comparator threshold configurable) reference. Voltages greater than the input comparator threshold value are considered open for SG pins and closed for SB configuration.

Voltages less than the input comparator threshold value are considered closed for SG pins and open for the SB configurations.

Programming features are defined in the [SPI control register definition](#) section of this data sheet.

The input comparator has hysteresis with the thresholds based on the closing of the switch (falling on SG, rising on SB).

The user must take care to keep power conditions within acceptable limits (package is capable of 2.0 W). Using many of the inputs with continuous wetting current levels causes overheating of the IC and may cause an overtemperature (OT) event to occur.



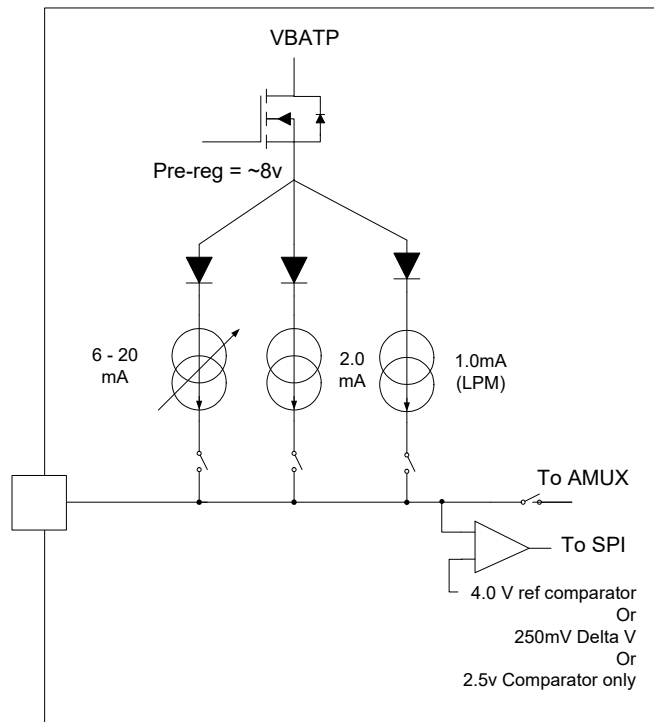

**Figure 17. SG block diagram**

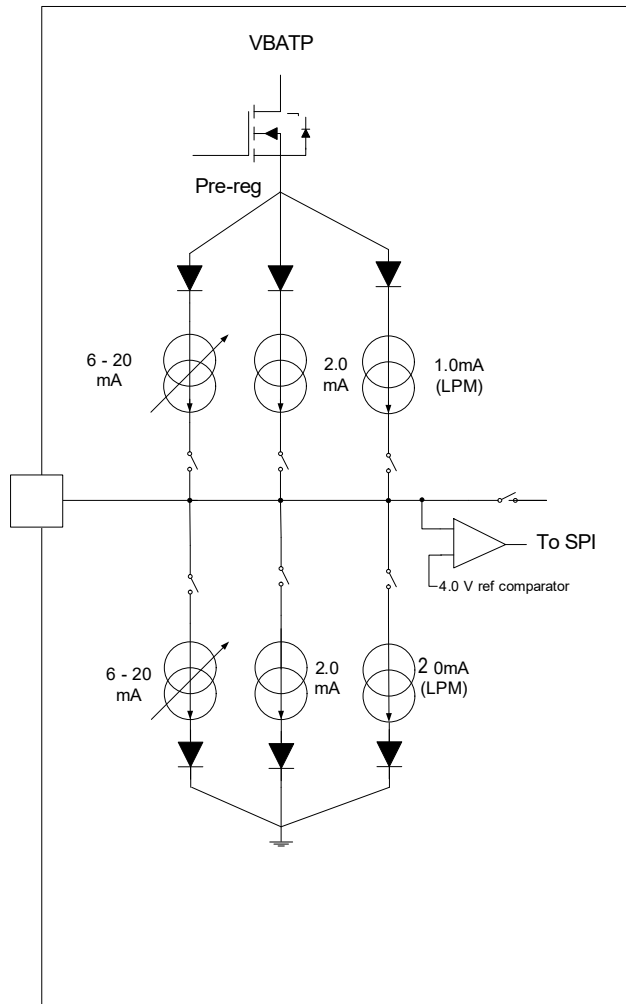

Figure 18. SP block diagram

## 7.4 Oscillator and timer control functional block

Two oscillators are generated in this block. A 4.0 MHz clock is used in Normal mode only, as well as a Low-power mode 192 kHz clock, which is on all the time. All timers are generated from these oscillators. The oscillator accuracy is 15 % for both, the 4.0 MHz clock and the 192 kHz clock. No calibration is needed and the accuracy is over voltage and temperature.

## 7.5 Temperature monitor and control functional block

The device has multiple thermal limit ( $t_{LIM}$ ) cells to detect thermal excursions in excess of 155 °C. The  $t_{LIM}$  cells from various locations on the IC are logically ORed together and communicated to the MCU as one  $t_{LIM}$  fault. When the  $t_{LIM}$  value is seen, the wetting current is lowered to 2.0 mA until the temperature has decreased beyond the  $t_{LIM(HYS)}$  value (the sustain current remains on or as selected). A hysteresis value of 15 °C exists to keep the device from cycling.

A thermal flag also exists to alert the system to increasing temperatures more than approximately 120 °C.

## 7.6 WAKE\_B control functional block

The WAKE\_B pin can operate as an open-drain output or a wake-up input. In the Normal Mode, the WAKE\_B pin is LOW. In the Low-power mode, the WAKE\_B pin is pulled HIGH. The WAKE\_B pin has an internal pull-up to VDDQ supply with an internal series diode to allow an external pull-up to VBATP if required.

As an input, in Low-power mode with the WAKE\_B pin pulled HIGH, when commanded LOW by MCU, the falling edge of WAKE\_B places the MC33978 in Normal mode. In Low-power mode if VDDQ goes low, the WAKE\_B pin can still wake the device based on the status of the WAKE\_B bit in the device configuration register, this allows the user to pull the WAKE\_B pin up to VBATP such that it can be used in VDDQ off setup.

As an output, WAKE\_B pin can drive either an MCU input or the EnableB of a regulator (possibly for VDDQ). WAKE\_B is driven Low during Normal mode regardless of the state of VDDQ. When the 33978 is in LPM, the WAKE\_B pin is released and is expected to be pulled up internally to VDDQ or externally to VBATP. When a valid wake-up event is detected, the 33978 wakes up from LPM and the WAKE\_B is driven Low (regardless of the state of VDDQ).

## 7.7 INT\_B functional block

INT\_B is an input/output pin in the 33978 device to indicate an interrupt event has occurred, as well as receiving interrupts from other devices when the INT\_B pins are wired ORed. The INT\_B pin is an open-drain output with an internal pull-up to VDDQ. In Normal mode, a switch state change triggers the INT\_B pin (when enabled). The INT\_B pin and INT\_B bit in the SPI register are latched on the falling edge of CS\_B. This permits the MCU to determine the origin of the interrupt. When two 33978 devices are used, only the device initiating the interrupt has the INT\_B bit set. The INT\_B pin and INTflg bit are cleared 1.0  $\mu$ s after the falling edge of CS B. The INT\_B pin does not clear with the rising edge of CS\_B if a switch contact change has occurred while CS\_B was Low.

In a multiple 33978 device system with WAKE\_B High and VDDQ on (Low-power mode), the falling edge of INT\_B places all 33978s in Normal mode. The INT\_B has the option of a pulsed output (pulsed low for INT<sub>pulse</sub> duration) or a latched low output. The default case is the latched low operation; the pulsed option is selectable via the SPI.

An INT\_B request by the MCU can be done by a SPI word and results in an INT<sub>PULSE</sub> of 100  $\mu$ s duration on the INT\_B pin.

The chip causes an INT\_B assertion for the following cases:

1. A change of state is detected
2. Interrupt timer expires
3. Any Wake-up event
4. Any faults detected
5. After a POR, the INT\_B pin states asserted during startup until the chip is ready to communicate

## 7.8 AMUX functional block

The analog voltage on switch inputs may be read by the MCU using the analog command ([Table 43](#)). Internal to the IC is a 24-to-1 analog multiplexer. The voltage present on the selected input pin is buffered and made available on the AMUX output pin. The output pin is clamped to a maximum of VDDQ regardless of the higher voltages present on the input pin. After an input has been selected as the analog, the corresponding bit in the next MISO data stream is logic [0]. When selecting a channel to be read as analog input, the user can also set the current level allowed in the AMUX output. Current level can be set to the programmed wetting current for the selected channel or set to high-impedance as defined in [Table 42](#).

When selecting an input to be sent to the AMUX output, that input is not polled or a wake-up enabled input from Low-power mode. The user should set the AMUX to “No input selected” or “Temp diode” before entering Low-power mode. The AMUX pin is not active during Low-power mode. The SG5 pin can also be used as a VBATP sense pin. An internal resistor divider of 1/6 is provided for conditioning the VBATP higher voltage to a level within the 0 V to VDDQ range.

Besides the default SPI input selection method, the AMUX has two hardware operation such that the user can select an specific input channel by physically driving the SG1, SG2 or SG3 pin (HW 3-bit), or by driving the SG1 and SG2 pins (HW 2-bit) as shown in [Table 9](#) and [Table 10](#). When using the AMUX hardwired options, the SG1, SG2, and SG3 inputs use a 2.5 V input voltage threshold to read a logic 0 or logic 1.

[Table 8](#) shows the AMUX selection methods configurable by the Aconfig0 and Aconfig1 bits in the Device Configuration register.

**Table 8. AMUX selection method**

Aconfig1	Aconfig0	AMUX Selection method
0	0	SPI (def)
0	1	SPI
1	0	HW 2-bit
1	1	HW 3-bit

**Table 9. AMUX hardware 3-bit**

Pins [SG3, SG2, SG1]	Output of AMUX
000	SG0
001	SG5
010	SG6
011	SG7
100	SG8
101	SG9
110	Temperature Diode
111	Battery Sense

**Table 10. AMUX hardware 2-bit**

Pins [SG2, SG1]	Output of AMUX
00	SG0
01	SG5
10	SG6
11	SG7

Since the device is required to meet the  $\pm 1.0$  V offset with ground, it is imperative that the user bring the sensor ground back to the 33978 when using the AMUX for accurate measurements to ensure any ground difference does not impact the device operation.

## 7.9 Serial peripheral interface (SPI)

The 33978 contains a serial peripheral interface consisting of Serial Clock (SCLK), Serial Data Out (MISO), Serial Data In (MOSI), and Chip Select Bar (CS\_B). The SPI interface is used to provide configuration, control, and status functions; the user may read the registers contents as well as read some status bits of the IC. This device is configured as an SPI slave.

All SPI transmissions to the 33978 must be done in exact increments of 32 bits (modulo 0 is ignored as well). The 33978 contains a data valid method via SCLK input to keep non-modulo-32 bit transmissions from being written into the IC. The SPI module also provides a daisy chain capability to accommodate MOSI to MISO wrap around (see [Figure 22](#)).

The SPI registers have a hashing technique to ensure that the registers are consistent with the programmed values. If the hashed value does not match the register status, a SPI bit is set as well as an interrupt to alert the MCU to this issue.

### 7.9.1 Chip select low (CS\_B)

The CS\_B input selects this device for serial transfers. On the falling edge of CS\_B, the MISO pin is released from tri-state mode, and all status information are latched in the SPI shift register. While CS\_B is asserted, register data is shifted in the MOSI pin and shifted out the MISO pin on each subsequent SCLK. On the rising edge of CS\_B, the MISO pin is tri-stated and the fault register reloaded (latched) with the current filtered status data. To allow sufficient time to reload the fault registers, the CS\_B pin must remain low for a minimum of  $t_{CSN}$  prior to going high again.

The CS\_B input contains a pull-up current source to VDDQ to command the de-asserted state should an open-circuit condition occur. This pin has threshold compatible voltages allowing proper operation with microprocessors using a 3.3 V to 5.0 V supply.

### 7.9.2 Serial clock (SCLK)

The SCLK input is the clock signal input for synchronization of serial data transfer. This pin has a threshold compatible voltages allowing proper operation with microprocessors using a 3.3 V to 5.0 V supply.

When CS\_B is asserted, both the Master Microprocessor and this device latch input data on the rising edge of SCLK. The SPI master typically shifts data out on the falling edge of SCLK, while this device shifts data out on the rising edge of SCLK, to allow more time to drive the MISO pin to the proper level.

This input is used as the input for the modulo-32 bit counter validation. Any SPI transmissions which are NOT exact multiples of 32 bits (i.e. clock edges) is treated as an illegal transmission. The entire frame is aborted and no information is changed in the configuration or control registers.

### 7.9.3 Serial data output (MISO)

The MISO output pin is in a tri-state condition when CS\_B is negated. When CS\_B is asserted, MISO is driven to the state of the MSB of the internal register and start shifting out the requested data from the MSB to the LSB. This pin supplies a "rail to rail" output, depending on the voltage at the VDDQ pin.

### 7.9.4 Serial data input (MOSI)

The MOSI input takes data from the master microprocessor while CS\_B is asserted. The MSB is the first bit of each word received on MOSI and the LSB is the last bit of each word received on MOSI. This pin has threshold level compatible input voltages allowing proper operation with microprocessors using a 3.3 V to 5.0 V ( $V_{DDQ}$ ) supply.

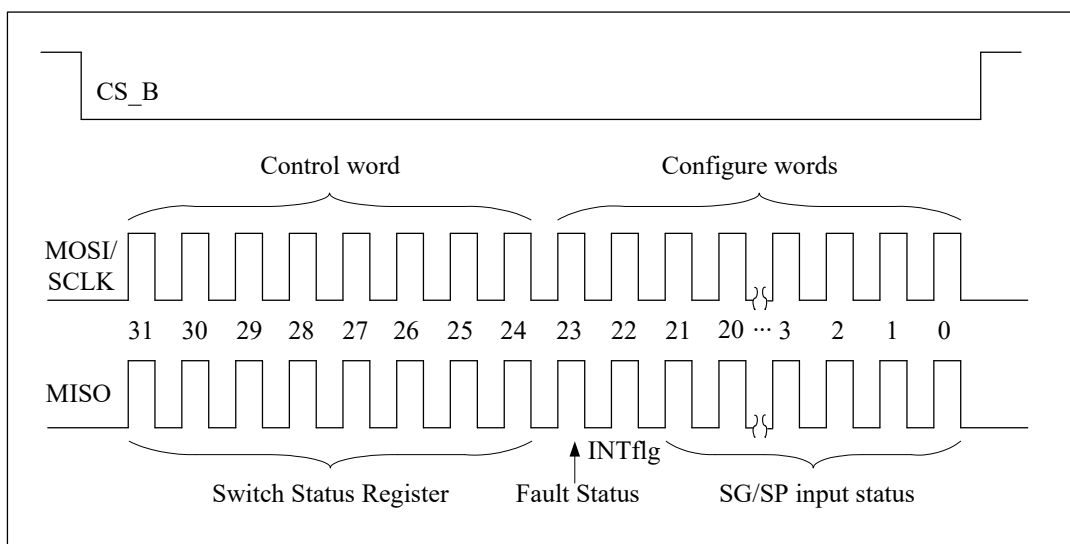

Figure 19. First SPI operation (after POR)

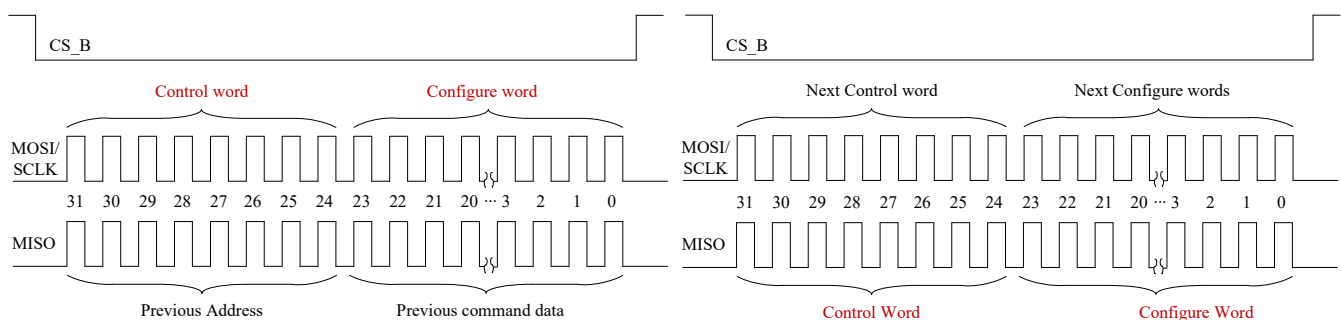
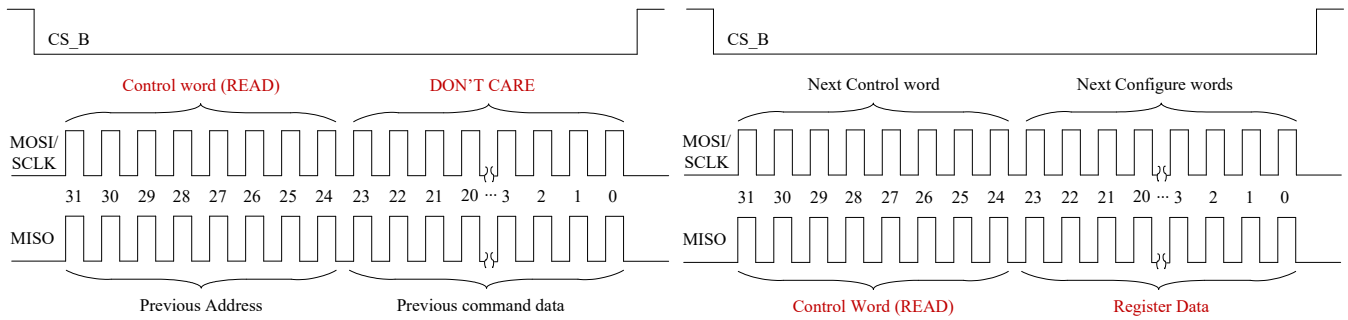
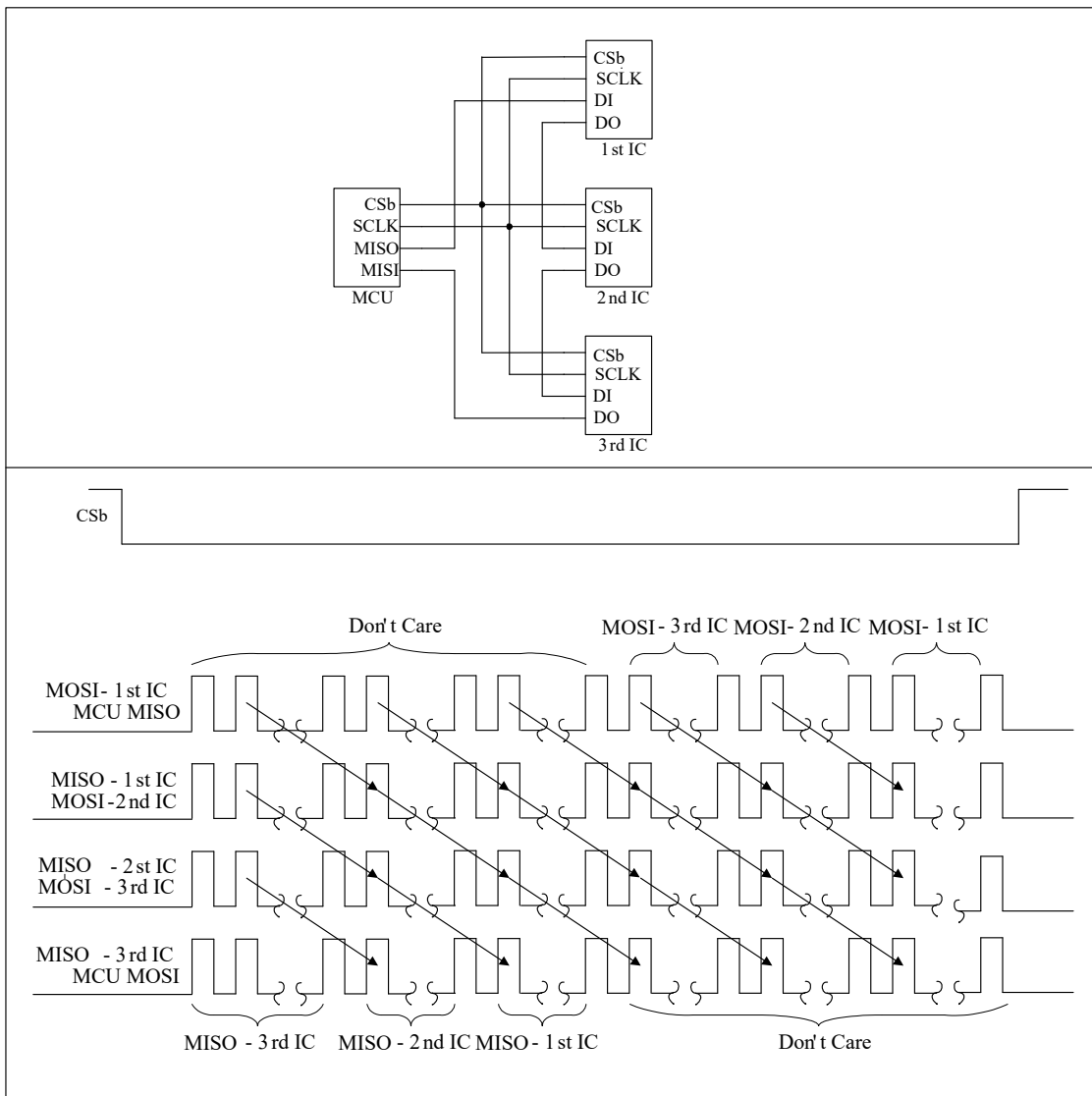

Figure 20. SPI write operation



**Figure 21. SPI read operation**



**Figure 22. Daisy chain SPI operation**

## 7.10 SPI control register definition

A 32-bit SPI allows the system microprocessor to configure the 33978 for each input as well as read out the status of each input. The SPI also allows the Fault Status and INTflg bits to be read via the SPI. The SPI MOSI bit definitions are given in [Table 11](#):

**Table 11. MOSI input register bit definition**

Register #	Register name	Address								Rb/W
0	SPI check	0	0	0	0	0	0	0	0	0
02/03	Device configuration register	0	0	0	0	0	0	0	1	0/1
04/05	Tri-state SP register	0	0	0	0	0	1	0	0	0/1
06/07	Tri-state SG register	0	0	0	0	0	1	1	0	0/1
08/09	Wetting current level SP register	0	0	0	0	1	0	0	0	0/1
0A/0B	Wetting current level SG register 0	0	0	0	0	1	0	1	0	0/1
0C/0D	Wetting current level SG register 1	0	0	0	0	1	1	0	0	0/1
16/17	Continuous wetting current SP register	0	0	0	1	0	1	1	0	0/1
18/19	Continuous Wetting Current SG Register	0	0	0	1	1	0	0	0	0/1
1A/1B	Interrupt enable SP register	0	0	0	1	1	0	1	0	0/1
1C/1D	Interrupt enable SG register	0	0	0	1	1	1	0	0	0/1
1E/1F	Low-power mode configuration	0	0	0	1	1	1	1	0	0/1
20/21	Wake-up enable register SP	0	0	1	0	0	0	0	0	0/1
22/23	Wake-up enable register SG	0	0	1	0	0	0	1	0	0/1
24/25	Comparator only SP	0	0	1	0	0	1	0	0	0/1
26/27	Comparator only SG	0	0	1	0	0	1	1	0	0/1
28/29	LPM voltage threshold SP configuration	0	0	1	0	1	0	0	0	0/1
2A/2B	LPM voltage threshold SG configuration	0	0	1	0	1	0	1	0	0/1
2C/2D	Polling current SP configuration	0	0	1	0	1	1	0	0	0/1
2E/2F	Polling current SG configuration	0	0	1	0	1	1	1	0	0/1
30/31	Slow polling SP	0	0	1	1	0	0	0	0	0/1
32/33	Slow polling SG	0	0	1	1	0	0	1	0	0/1
34/35	Wake-up debounce SP	0	0	1	1	0	1	0	0	0/1
36/37	Wake-up debounce SG	0	0	1	1	0	1	1	0	0/1
39	Enter low-power mode	0	0	1	1	1	0	0	1	
3A/3B	AMUX control register	0	0	1	1	1	0	1	0	0/1
3E	Read switch status	0	0	1	1	1	1	1	0	
42	Fault status register	0	1	0	0	0	0	1	0	
47	Interrupt request	0	1	0	0	0	1	1	1	
49	Reset register	0	1	0	0	1	0	0	1	

The 32-bit SPI word consists of a command word (8-bit) and three configure words (24-bit). The 8 MSB bits are the command bits that select what type of configuration is to occur. The remaining 24-bits are used to select the inputs to be configured.

- Bit 31 - 24 = Command word: Use to select what configuration is to occur (example: setting wake-up enable command)
- Bit 23 - 0 = Sgn input select word: Use these bits in conjunction with the command word to determine which input is setup.

Configuration registers may be read or written to. To read the contents of a configuration register, send the register address + '0' on the LSB of the command word; the contents of the corresponding register will be shifted out of the MISO buffer in the next SPI cycle. When a Read command is sent, the answer (in the next SPI transaction) includes the Register address in the upper byte (see [Figure 21](#)).

Read example:

- Send 0x0C00\_0000 Receive: 8000\_0000 (for example after a POR)
- Send 0x0000\_0000 Receive: 0C00\_0000 (address + register data)

The first response from the device after a POR event is a Read Status register (0x3Exxxxxx where x is the status of the inputs). This is the same for exiting the Low-power mode (see [Figure 19](#)).

To write into a configuration register, send the register Address + '1' on the LSB of the command word and the configuration data on the next 24 bits. The new value of the register will be shifted out of the MISO buffer in the next SPI cycle, along with the register address.

[Table 7.10.1](#) provides a general overview of the functional SPI commands and configuration bits.

**Table 12. Functional SPI register map**

Commands	[31-25]	24	23	22	21	20	19	18	17	16	15	14	13	12	11	10	9	8	7	6	5	4	3	2	1	0
	Address	R/W																								
SPI check	0000000	0	X	X	X	X	X	X	X	X	X	X	X	X	X	X	X	X	X	X	X	X	X	X	X	X
Device Configuration	0000001	0/1	FS	INT	X	X	X	X	X	X	X	X	SBPOLL TIME	VBATP OV Disable	WAKE_B Pull up	IntB_Out	aconfig1	aconfig0	SP7	SP6	SP5	SP4	SP3	SP2	SP1	SP0
Tri-State Enable SP	0000010	0/1	FS	INT	X	X	X	X	X	X	X	X	X	X	X	X	X	X	SP7	SP6	SP5	SP4	SP3	SP2	SP1	SP0
Tri-State Enable SG	0000011	0/1	FS	INT	X	X	X	X	X	X	X	X	SG13	SG12	SG11	SG10	SG9	SG8	SG7	SG6	SG5	SG4	SG3	SG2	SG1	SG0
Wetting Current Level SP	0000100	0/1	SP7[2-0]			SP6[2-0]			SP5[2-0]			SP4[2-0]			SP3[2-0]			SP2[2-0]			SP1[2-0]			SP0[2-0]		
Wetting Current Level SG 0	0000101	0/1	SG7[2-0]			SG6[2-0]			SG5[2-0]			SG4[2-0]			SG3[2-0]			SG2[2-0]			SG1[2-0]			SG0[2-0]		
Wetting Current Level SG 1	0000110	0/1	FS	INT	X	X	X	X	SG13[2-0]			SG12[2-0]			SG11[2-0]			SG10[2-0]			SG9[2-0]			SG8[2-0]		
Continuous Wetting Current Enable SP	0001011	0/1	FS	INT	X	X	X	X	X	X	X	X	X	X	X	X	X	X	SP7	SP6	SP5	SP4	SP3	SP2	SP1	SP0
Continuous Wetting Current Enable SG	0001100	0/1	FS	INT	X	X	X	X	X	X	X	X	SG13	SG12	SG11	SG10	SG9	SG8	SG7	SG6	SG5	SG4	SG3	SG2	SG1	SG0
Interrupt Enable SP	0001101	0/1	FS	INT	X	X	X	X	X	X	X	X	X	X	X	X	X	X	SP7	SP6	SP5	SP4	SP3	SP2	SP1	SP0
Interrupt Enable SG	0001110	0/1	FS	INT	X	X	X	X	X	X	X	X	SG13	SG12	SG11	SG10	SG9	SG8	SG7	SG6	SG5	SG4	SG3	SG2	SG1	SG0
Low-power mode configuration	0001111	0/1	FS	INT	X	X	X	X	X	X	X	X	X	X	X	X	X	X	int3	int2	int2	int0	poll3	poll2	poll1	poll0
Wake-Up Enable SP	0010000	0/1	FS	INT	X	X	X	X	X	X	X	X	X	X	X	X	X	X	SP7	SP6	SP5	SP4	SP3	SP2	SP1	SP0
Wake-Up Enable SG	0010001	0/1	FS	INT	X	X	X	X	X	X	X	X	SG13	SG12	SG11	SG10	SG9	SG8	SG7	SG6	SG5	SG4	SG3	SG2	SG1	SG0
LPM Comparator Only SP	0010010	0/1	FS	INT	X	X	X	X	X	X	X	X	X	X	X	X	X	X	SP7	SP6	SP5	SP4	SP3	SP2	SP1	SP0
LPM Comparator Only SG	0010011	0/1	FS	INT	X	X	X	X	X	X	X	X	SG13	SG12	SG11	SG10	SG9	SG8	SG7	SG6	SG5	SG4	SG3	SG2	SG1	SG0
LPM Voltage Threshold SP	0010100	0/1	FS	INT	X	X	X	X	X	X	X	X	X	X	X	X	X	X	SP7	SP6	SP5	SP4	SP3	SP2	SP1	SP0
LPM Voltage Threshold SG	0010101	0/1	FS	INT	X	X	X	X	X	X	X	X	SG13	SG12	SG11	SG10	SG9	SG8	SG7	SG6	SG5	SG4	SG3	SG2	SG1	SG0
LPM Polling current config SP	0010110	0/1	FS	INT	X	X	X	X	X	X	X	X	X	X	X	X	X	X	SP7	SP6	SP5	SP4	SP3	SP2	SP1	SP0
LPM Polling current config SG	0010111	0/1	FS	INT	X	X	X	X	X	X	X	X	SG13	SG12	SG11	SG10	SG9	SG8	SG7	SG6	SG5	SG4	SG3	SG2	SG1	SG0
LPM Slow Polling SP	0011000	0/1	FS	INT	X	X	X	X	X	X	X	X	X	X	X	X	X	X	SP7	SP6	SP5	SP4	SP3	SP2	SP1	SP0
LPM Slow Polling SG	0011001	0/1	FS	INT	X	X	X	X	X	X	X	X	SG13	SG12	SG11	SG10	SG9	SG8	SG7	SG6	SG5	SG4	SG3	SG2	SG1	SG0
Wake-Up Debounce SP	0011010	0/1	FS	INT	X	X	X	X	X	X	X	X	X	X	X	X	X	X	SP7	SP6	SP5	SP4	SP3	SP2	SP1	SP0
Wake-Up Debounce SG	0011011	0/1	FS	INT	X	X	X	X	X	X	X	X	SG13	SG12	SG11	SG10	SG9	SG8	SG7	SG6	SG5	SG4	SG3	SG2	SG1	SG0
Enter Low-power mode	0011100	1	FS	INT	X	X	X	X	X	X	X	X	X	X	X	X	X	X	X	X	X	X	X	X	X	X
AMUX Channel Select SPI	0011101	0/1	FS	INT	X	X	X	X	X	X	X	X	X	X	X	X	X	X	X	asett	asel5	asel4	asel3	asel2	asel1	asel0
Read Switch Status	0011111	0	FAULT STATUS	INTflg	SP7	SP6	SP5	SP4	SP3	SP2	SP1	SP0	SG13	SG12	SG11	SG10	SG9	SG8	SG7	SG6	SG5	SG4	SG3	SG2	SG1	SG0
Fault Status	0100001	0	X	INTflg	X	X	X	X	X	X	X	X	X	X	X	SPI Error	hash fault	X	UV	OV	TempFlag	OT	INT_B wake	WAKE_B	SpiWake	POR
Interrupt Pulse Request	0100011	1	FS	INT	X	X	X	X	X	X	X	X	X	X	X	X	X	X	X	X	X	X	X	X	X	X
Reset	0100100	1	X	X	X	X	X	X	X	X	X	X	X	X	X	X	X	X	X	X	X	X	X	X	X	X

**Notes**

28. FS = FAULT STATUS (available for reading on MISO return word)
29. INT = INTflg (available for reading on MISO return word)



## 7.10.1 SPI check

The MCU may check the communication with the IC by using the SPI Check register. The MCU sends the command and the response during the next SPI transaction will be 0x123456. The SPI Check command does not return Fault Status or INTflg bit, thus interrupts will not be cleared.

**Table 13. SPI check command**

Register address	R	SPI data bits [23 - 0]
[31-25]	[24]	bits [23 - 16]
0000_000	0	0000_0000
		bits [15 - 8]
		0000_0000
		bits [7 - 0]
		0000_0000
<b>MISO return word</b>		<b>0x00123456</b>

## 7.10.2 Device configuration register

The device has various configuration settings that are global in nature. The configuration settings are as follows:

- When the 33978 is in the overvoltage region, a Logic [0] on the VBATP OV bit limits the wetting current on all input channels to 2 mA and the 33978 will not be able to enter into the Low-power mode. A Logic [1] allows the device to operate normally even in the overvoltage region. The OV flag will be set when the device enters in the OV region, regardless the value of the VBATP OV bit.
- WAKE\_B can be used to enable an external power supply regulator to supply the VDDQ voltage rail. When the WAKE\_B VDDQ check bit is a Logic [0], the WAKE\_B pin is expected to be pulled-up internally or externally to VDDQ and VDDQ is expected to go low, therefore the 33978 does not wake-up on the falling edge of WAKE\_B. A Logic [1], assumes the user is using an external pull-up to V<sub>BATP</sub> or V<sub>DDQ</sub> (when V<sub>DDQ</sub> is not expected to be off) and the IC wakes up on a falling edge of WAKE\_B.
- INT\_B out is used to select how the INT\_B pin operates when an interrupt occurs. The IC is able to pulse low [1] or latch low [0].
- Aconfig[1-0] is used to determine the method of selecting the AMUX output, either a SPI command or using a hardwired setup using SG[3-1].
- Inputs SP0-7 may be programmable for switch-to-battery or switch-to-ground. These inputs types are defined using the settings command. To set a SPn input for switch-to-battery, a logic [1] for the appropriate bit must be set. To set a SPn input for switch-to-ground, a logic [0] for the appropriate bit must be set. The MCU may change or update the programmable switch register via software at any time in Normal mode. Regardless of the setting, when the SPn input switch is closed a logic [1] is placed in the serial output response register.

**Table 14. Device configuration register**

Register address	R/W	SPI data bits [23 - 0]							
[31-25]	[24]	bit 23	bit 22	bit 21	bit 20	bit 19	bit 18	bit 17	bit 16
0000_001	0/1	Unused							
Default on POR		0	0	0	0	0	0	0	0
		bit 15	bit 14	bit 13	bit 12	bit 11	bit 10	bit 9	bit 8
		Unused		SBPOLL TIME	VBATP OV disable	WAKE_B VDDQ Check	INT_B out	Aconfig1	Aconfig0
		0	0	0	0	1	0	0	0
		bit 7	bit 6	bit 5	bit 4	bit 3	bit 2	bit 1	bit 0
		SP7	SP6	SP5	SP4	SP3	SP2	SP1	SP0
		1	1	1	1	1	1	1	1
<b>MISO return word</b>		bit [23]	bit [22]	<b>bits [21 - 0]</b>					
0000_001[R/W]		FAULT STATUS	INTflg	Register Data					

**Table 15. Device configuration bits definition**

Bit	Functions	Default value	Description
23-14	Unused	0	Unused
13	SBPOLLTIME	0	Select the polling time for SP channels configured as SB. <ul style="list-style-type: none"> <li>A logic [0] set the active polling timer to 1ms,</li> <li>A logic [1] sets the active polling timer to 55 μs.</li> </ul>
12	VBATP OV Disable	0	VBATP Overvoltage protection <ul style="list-style-type: none"> <li>0 - Enabled</li> <li>1 - Disable</li> </ul>
11	WAKE_B VDDQ Check	1	Enable/Disable WAKE_B to wake-up the device on falling edge when V <sub>DDQ</sub> is not present. <ul style="list-style-type: none"> <li>0 - WAKE_B is pulled up to V<sub>DDQ</sub> (internally and/or externally). WAKE_B is ignored while in LPM if V<sub>DDQ</sub> is low.</li> <li>1 - WAKE_B is externally pulled up to V<sub>BATP</sub> or V<sub>DDQ</sub> and wakes upon a falling edge of the WAKE_B pin regardless of the V<sub>DDQ</sub> status.(V<sub>DDQ</sub> is not expected to go low)</li> </ul>
10	Int_B_Out	0	Interrupt pin behavior <ul style="list-style-type: none"> <li>0 - INT pin stays low when interrupt occurs</li> <li>1 - INT pin pulse low and return high</li> </ul>
9-8	Aconfig(1-0)	00	Configure the AMUX output control method <ul style="list-style-type: none"> <li>00 - SPI (default)</li> <li>01 - SPI</li> <li>10 - HW 2bit</li> <li>11 - HW 3bit</li> </ul> Refer to section 7.8, "AMUX functional block" for details on 2 and 3 bit hardwire configuration.
7-0	SP7 - SP0	1111_1111	Configure the SP pin as Switch to Battery (SB) or Switch to ground (SG) <ul style="list-style-type: none"> <li>0 - Switch to Ground</li> <li>1 - Switch to Battery</li> </ul>

### 7.10.3 Tri-state SP register

The tri-state command is used to set the input nodes as high-impedance (Table 16). By setting the tri-state register bit to logic [1], the input is high-impedance regardless of the Wetting current setting. The configurable comparator (4.0 V default) on each input remains active. The MCU may change or update the tri-state register via software at any time in Normal mode. The tri-state register defaults to 1 (inputs are tri-stated). Any inputs in tri-state is still polled in LPM but the current source is not active during this time. The determination of change of state occurs at the end of the  $t_{ACTIVEPOLL}$  and the wake-up decision is made.

**Table 16. Tri-state SP register**

Register address	R/W	SPI data bits [23 - 0]							
[31-25]	[24]	bit 23	bit 22	bit 21	bit 20	bit 19	bit 18	bit 17	bit 16
0000_010	0/1	Unused							
Default on POR		0	0	0	0	0	0	0	0
		bit 15	bit 14	bit 13	bit 12	bit 11	bit 10	bit 9	bit 8
		Unused							
		0	0	0	0	0	0	0	0
		bit 7	bit 6	bit 5	bit 4	bit 3	bit 2	bit 1	bit 0
		SP7	SP6	SP5	SP4	SP3	SP2	SP1	SP0
		1	1	1	1	1	1	1	1
<b>MISO return word</b>		bit [23]	bit [22]	bits [21 - 0]					
0000_010[R/W]		FAULT STATUS	INTflg	Register Data					

### 7.10.4 Tri-state SG register

The tri-state command is used to set the input nodes as high-impedance (Table 17). By setting the tri-state register bit to logic [1], the input is high-impedance regardless of the Wetting command setting. The configurable comparator (4.0 V default) on each input remains active. The MCU may change or update the tri-state register via software at any time in Normal mode. The tri-state register defaults to 1 (inputs are tri-stated). Any inputs in tri-state is still polled in LPM but the current source is not active during this time. The determination of change of state occurs at the end of the  $t_{ACTIVEPOLL}$  and the wake-up decision is made.

**Table 17. Tri-state SG register**

Register address	R/W	SPI data bits [23 - 0]							
[31-25]	[24]	bit 23	bit 22	bit 21	bit 20	bit 19	bit 18	bit 17	bit 16
0000_011	0/1	Unused							
Default on POR		0	0	0	0	0	0	0	0
		bit 15	bit 14	bit 13	bit 12	bit 11	bit 10	bit 9	bit 8
		Unused		SG13	SG12	SG11	SG10	SG9	SG8
		0	0	1	1	1	1	1	1
		bit 7	bit 6	bit 5	bit 4	bit 3	bit 2	bit 1	bit 0
		SG7	SG6	SG5	SG4	SG3	SG2	SG1	SG0
		1	1	1	1	1	1	1	1
<b>MISO return word</b>		bit [23]	bit [22]	bits [21 - 0]					
0000_011[R/W]		FAULT STATUS	INTflg	Register Data					

## 7.10.5 Wetting current level SP register

The IC contains configurable wetting currents (Default = 16 mA). Three bits are used to control each individual input pin with the values set in [Table 18](#). The MCU may change or update the wetting current register via software at any time in Normal mode.

**Table 18. Wetting current level SP register**

Register address	R/W	SPI data bits [23 - 0]					
[31-25]	[24]	bit [23 - 21]		bit [20 - 18]		bit [17 - 16]	
0000_100	0/1	SP7 [2-0]		SP6[2-0]		SP5[2-1]	
Default on POR		110		110		11	
		bit [15]	bit [14 - 12]		bit [11 - 9]		bit [8]
		SP5[0]	SP4 [2-0]		SP3[2-0]		SP2[2]
		0	110		110		1
		bit [7 - 6]		bit [5 - 3]		bit [2 - 0]	
		SP2[1-0]		SP1[2-0]		SP0[2-0]	
		10		110		110	
<b>MISO return word</b>		<b>bits [23 - 0]</b>					
0000_100[R/W]		Register Data					

See [Table 21](#) for the selectable Wetting Current level values for both SPx and SGx pins.

## 7.10.6 Wetting current level SG register 0

The IC contains configurable wetting currents (Default = 16 mA). Three bits are used to control each individual input pin with the values set in [Table 19](#). The MCU may change or update the wetting current register via software at any time in Normal mode.

**Table 19. Wetting current level SG register 0**

Register address	R/W	SPI data bits [23 - 0]					
[31-25]	[24]	bit [23 - 21]		bit [20 - 18]		bit [17 - 16]	
0000_101	0/1	SG7 [2-0]		SG6[2-0]		SG5[2-1]	
Default on POR		110		110		11	
		bit [15]	bit [14 - 12]		bit [11 - 9]		bit [8]
		SG5[0]	SG4 [2-0]		SG3[2-0]		SG2[2]
		0	110		110		1
		bit [7 - 6]		bit [5 - 3]		bit [2 - 0]	
		SG2[1-0]		SG1[2-0]		SG0[2-0]	
		10		110		110	
<b>MISO return word</b>		<b>bits [23 - 0]</b>					
0000_101[R/W]		Register Data					

See [Table 21](#) for the selectable Wetting Current level values for both SPx and SGx pins.

## 7.10.7 Wetting current level SG register 1

The IC contains configurable wetting currents (Default = 16 mA). Three bits are used to control each individual input pin with the values set in [Table 20](#). The MCU may change or update the wetting current register via software at any time in Normal mode.

**Table 20. Wetting current level SG register 1**

Register address	R/W	SPI data bits [23 - 0]					
[31-25]	[24]	bit [23 - 21]		bit [20 - 18]		bit [17 - 16]	
0000_110	0/1	Unused				SG13[2-1]	
Default on POR		0				11	
		bit [15]	bit [14 - 12]		bit [11 - 9]		bit [8]
		SG13[0]	SG12 [2-0]		SG11[2-0]		SG10[2]
		0	110		110		1
		bit [7 - 6]		bit [5 - 3]		bit [2 - 0]	
		SG10[1-0]		SG9[2-0]		SG8[2-0]	
		10		110		110	
<b>MISO return word</b>		<b>bits [23 - 0]</b>					
0000_110[R/W]		Register Data					

See [Table 21](#) for the selectable Wetting Current level values for both SPx and SGx pins.

**Table 21. SPx/SGx selectable wetting current levels**

SPx/SGx[2-0]			Wetting Current Level
bit 2	bit 1	bit 0	
0	0	0	2.0 mA
0	0	1	6.0 mA
0	1	0	8.0 mA
0	1	1	10 mA
1	0	0	12 mA
1	0	1	14 mA
1	1	0	16 mA
1	1	1	20 mA

## 7.10.8 Continuous wetting current SP register

Each switch input has a designated 20 ms timer. The timer starts when the specific switch input crosses the comparator threshold. When the 20 ms timer expires, the contact current is reduced from the configured wetting current (16 mA) to the Sustain current. The wetting current is defined to be an elevated level that reduces to the lower sustain current level after the timer has expired. With multiple wetting current timers disabled, power dissipation for the IC must be considered.

The MCU may change or update the continuous wetting current register via software at any time in Normal mode. This allows the MCU to control the amount of time wetting current is applied to the switch contact. Programming the continuous wetting current bit to logic [0] operates normally with a higher wetting current followed by sustain current after 20 ms (pulsed Wetting current operation). Programming to logic [1] enables the continuous wetting current ([Table 22](#)) and results in a full time wetting current level. The continuous wetting current register defaults to 0 (pulse wetting current operation).

**Table 22. Continuous wetting current SP register**

Register address	R/W	SPI data bits [23 - 0]							
[31-25]	[24]	bit 23	bit 22	bit 21	bit 20	bit 19	bit 18	bit 17	bit 16
0001_011	0/1	Unused							
Default on POR		0	0	0	0	0	0	0	0
		bit 15	bit 14	bit 13	bit 12	bit 11	bit 10	bit 9	bit 8
		Unused							
		0	0	0	0	0	0	0	0
		bit 7	bit 6	bit 5	bit 4	bit 3	bit 2	bit 1	bit 0
		SP7	SP6	SP5	SP4	SP3	SP2	SP1	SP0
		0	0	0	0	0	0	0	0
MISO return word		bit [23]	bit [22]	bits [21 - 0]					
0001_011[R/W]		FAULT STATUS	INTflg	Register Data					

## 7.10.9 Continuous Wetting Current SG Register

Each switch input has a designated 20 ms timer. The timer starts when the specific switch input crosses the comparator threshold. When the 20 ms timer expires, the contact current is reduced from the configured wetting current (16 mA) to 2.0 mA. The wetting current is defined to be at an elevated level that reduces to the lower sustain current level after the timer has expired. With multiple wetting current timers disabled, power dissipation for the IC must be considered.

The MCU may change or update the continuous wetting current register via software at any time in Normal mode. This allows the MCU to control the amount of time wetting current is applied to the switch contact. Programming the continuous wetting current bit to logic [0] operates normally with a higher wetting current followed by sustain current after 20 ms (Pulse wetting current operation). Programming to logic [1] enables the continuous wetting current ([Table 23](#)) and results in a full time wetting current level. The continuous wetting current register defaults to 0 (pulse wetting current operation).

**Table 23. Continuous wetting current SG register**

Register address	R/W	SPI data bits [23 - 0]							
[31-25]	[24]	bit 23	bit 22	bit 21	bit 20	bit 19	bit 18	bit 17	bit 16
0001_100	0/1	Unused							
Default on POR		0	0	0	0	0	0	0	0
		bit 15	bit 14	bit 13	bit 12	bit 11	bit 10	bit 9	bit 8
		Unused		SG13	SG12	SG11	SG10	SG9	SG8
		0	0	0	0	0	0	0	0
		bit 7	bit 6	bit 5	bit 4	bit 3	bit 2	bit 1	bit 0
		SG7	SG6	SG5	SG4	SG3	SG2	SG1	SG0
		0	0	0	0	0	0	0	0
MISO return word		bit [23]	bit [22]	bits [21 - 0]					
0001_100[R/W]		FAULT STATUS	INTflg	Register Data					

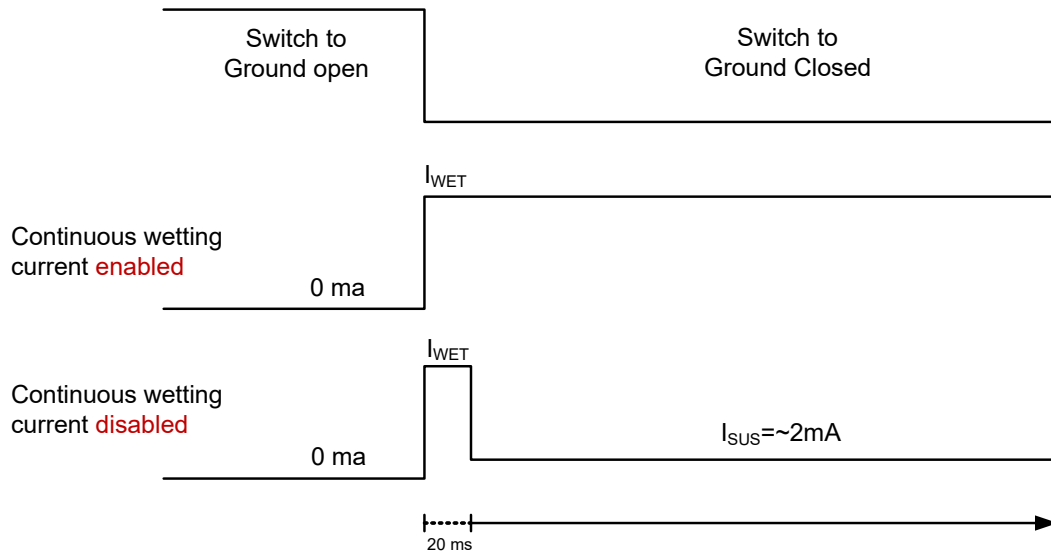

**Figure 23. Pulsed/continuous wetting current configuration**

## 7.10.10 Interrupt enable SP register

The interrupt register defines the inputs that are allowed to Interrupt the 33978 Normal mode. Programming the interrupt bit to logic [0] disables the specific input from generating an interrupt. Programming the interrupt bit to logic [1] enables the specific input to generate an interrupt with switch change of state. The MCU may change or update the interrupt register via software at any time in Normal mode. The Interrupt register defaults to logic [1] (Interrupt enabled).

**Table 24. Interrupt enable SP register**

Register address	R/W	SPI data bits [23 - 0]							
[31-25]	[24]	bit 23	bit 22	bit 21	bit 20	bit 19	bit 18	bit 17	bit 16
0001_101	0/1	Unused							
Default on POR		0	0	0	0	0	0	0	0
		bit 15	bit 14	bit 13	bit 12	bit 11	bit 10	bit 9	bit 8
		Unused							
		0	0	0	0	0	0	0	0
		bit 7	bit 6	bit 5	bit 4	bit 3	bit 2	bit 1	bit 0
		SP7	SP6	SP5	SP4	SP3	SP2	SP1	SP0
		1	1	1	1	1	1	1	1
<b>MISO return word</b>		bit [23]	bit [22]	<b>bits [21 - 0]</b>					
0001_101[R/W]		FAULT STATUS	INTflg	Register Data					

## 7.10.11 Interrupt enable SG register

The interrupt register defines the inputs that are allowed to Interrupt the 33978 Normal mode. Programming the interrupt bit to logic [0] disables the specific input from generating an interrupt. Programming the interrupt bit to logic [1] enables the specific input to generate an interrupt with switch change of state. The MCU may change or update the interrupt register via software at any time in Normal mode. The Interrupt register defaults to logic [1] (Interrupt enabled).

**Table 25. Interrupt enable SG register**

Register address	R/W	SPI data bits [23 - 0]							
[31-25]	[24]	bit 23	bit 22	bit 21	bit 20	bit 19	bit 18	bit 17	bit 16
0001_110	0/1	Unused							
Default on POR		0	0	0	0	0	0	0	0
		bit 15	bit 14	bit 13	bit 12	bit 11	bit 10	bit 9	bit 8
		Unused		SG13	SG12	SG11	SG10	SG9	SG8
		0	0	1	1	1	1	1	1
		bit 7	bit 6	bit 5	bit 4	bit 3	bit 2	bit 1	bit 0
		SG7	SG6	SG5	SG4	SG3	SG2	SG1	SG0
		1	1	1	1	1	1	1	1
<b>MISO return word</b>		bit [23]	bit [22]	<b>bits [21 - 0]</b>					
0001_110[R/W]		FAULT STATUS	INTflg	Register Data					



## 7.10.12 Low-power mode configuration

The device has various configuration settings for the Low-power mode operation. The configuration settings are as follows:

int[3-0] is used to set the interrupt timer value. With the interrupt timer set, the IC wakes up after the selected timer expires and issue an interrupt. This register can be selected to be OFF such that the IC does not wake-up from an interrupt timer.

poll[3-0] is used to set the normal polling rate for the IC. The polling rate is the time between polling events. The current sources become active at this time for a time of  $t_{ACTIVESGPOLLING}$  or  $t_{ACTIVESBPOLLING}$  for SG or SB channels respectively.

**Table 26. Low-power mode configuration register**

Register address	R/W	SPI data bits [23 - 0]							
[31-25]	[24]	bit 23	bit 22	bit 21	bit 20	bit 19	bit 18	bit 17	bit 16
0001_111	0/1	Unused							
Default on POR		0	0	0	0	0	0	0	0
		bit 15	bit 14	bit 13	bit 12	bit 11	bit 10	bit 9	bit 8
		Unused							
		0	0	0	0	0	0	0	0
		bit 7	bit 6	bit 5	bit 4	bit 3	bit 2	bit 1	bit 0
		int3	int2	int1	int0	poll3	poll2	poll1	poll0
		0	0	0	0	1	1	1	1
MISO return word		bit [23]	bit [22]	bits [21 - 0]					
0001_111[R/W]		FAULT STATUS	INTfig	Register Data					

**Table 27. Low-power mode configuration bits definition**

Bit	Functions	Default value	Description	
23 - 8	Unused	0	Unused	
7 - 4	int[3-0]	0000	Set the Interrupt timer value	
			<ul style="list-style-type: none"> <li>• 0000 - OFF</li> <li>• 0001 - 6.0 ms</li> <li>• 0010 - 12 ms</li> <li>• 0011 - 24 ms</li> <li>• 0100 - 48 ms</li> <li>• 0101 - 96 ms</li> <li>• 0110 - 192 ms</li> <li>• 0111 - 394 ms</li> </ul>	<ul style="list-style-type: none"> <li>• 1000 - 4.0 ms</li> <li>• 1001 - 8.0 ms</li> <li>• 1010 - 16 ms</li> <li>• 1011 - 32 ms</li> <li>• 1100 - 64 ms</li> <li>• 1101 - 128 ms</li> <li>• 1110 - 256 ms</li> <li>• 1111 - 512 ms</li> </ul>
3 - 0	poll[3-0]	1111	Set the polling rate for switch detection	
			<ul style="list-style-type: none"> <li>• 0000 - 3.0 ms</li> <li>• 0001 - 6.0 ms</li> <li>• 0010 - 12 ms</li> <li>• 0011 - 24 ms</li> <li>• 0100 - 48 ms</li> <li>• 0101 - 68 ms</li> <li>• 0110 - 76 ms</li> <li>• 0111 - 128 ms</li> </ul>	<ul style="list-style-type: none"> <li>• 1000 - 32 ms</li> <li>• 1001 - 36 ms</li> <li>• 1010 - 40 ms</li> <li>• 1011 - 44 ms</li> <li>• 1100 - 52 ms</li> <li>• 1101 - 56 ms</li> <li>• 1110 - 60 ms</li> <li>• 1111 - 64 ms (default)</li> </ul>

## 7.10.13 Wake-up enable register SP

The wake-up register defines the inputs that are allowed to wake the 33978 from Low-power mode. Programming the wake-up bit to logic [0] disables the specific input from waking the IC ([Table 28](#)). Programming the wake-up bit to logic [1] enables the specific input to wake-up with switch change of state. The MCU may change or update the wake-up register via software at any time in Normal mode. The Wake-up register defaults to logic [1] (wake-up enabled). If all channels (SG and SB) have the Wake-up bit disabled, the device disables the polling timer to reduce the current consumption during Low-power mode.

**Table 28. Wake-up enable SP register**

Register address	R/W	SPI data bits [23 - 0]							
[31-25]	[24]	bit 23	bit 22	bit 21	bit 20	bit 19	bit 18	bit 17	bit 16
0010_000	0/1	Unused							
Default on POR		0	0	0	0	0	0	0	0
		bit 15	bit 14	bit 13	bit 12	bit 11	bit 10	bit 9	bit 8
		Unused							
		0	0	0	0	0	0	0	0
		bit 7	bit 6	bit 5	bit 4	bit 3	bit 2	bit 1	bit 0
		SP7	SP6	SP5	SP4	SP3	SP2	SP1	SP0
		1	1	1	1	1	1	1	1
<b>MISO return word</b>		bit [23]	bit [22]	<b>bits [21 - 0]</b>					
0010_000[R/W]		FAULT STATUS	INTflg	Register Data					

## 7.10.14 Wake-up enable register SG

The wake-up register defines the inputs that are allowed to wake the 33978 from Low-power mode. Programming the wake-up bit to logic [0] disables the specific input from waking the IC ([Table 29](#)). Programming the wake-up bit to logic [1] enables the specific input to wake-up with any switch change of state. The MCU may change or update the wake-up register via software at any time in Normal mode. The Wake-up register defaults to logic [1] (wake-up enabled). If all channels (SG and SB) have the Wake-up bit disabled, the device disables the polling timer to reduce the current consumption during Low-power mode.

**Table 29. Wake-up enable SG register**

Register address	R/W	SPI data bits [23 - 0]							
[31-25]	[24]	bit 23	bit 22	bit 21	bit 20	bit 19	bit 18	bit 17	bit 16
0010_001	0/1	Unused							
Default on POR		0	0	0	0	0	0	0	0
		bit 15	bit 14	bit 13	bit 12	bit 11	bit 10	bit 9	bit 8
		Unused		SG13	SG12	SG11	SG10	SG9	SG8
		0	0	1	1	1	1	1	1
		bit 7	bit 6	bit 5	bit 4	bit 3	bit 2	bit 1	bit 0
		SG7	SG6	SG5	SG4	SG3	SG2	SG1	SG0
		1	1	1	1	1	1	1	1
<b>MISO return word</b>		bit [23]	bit [22]	<b>bits [21 - 0]</b>					
0010_001[R/W]		FAULT STATUS	INTflg	Register Data					

## 7.10.15 Comparator only SP

The comparator only register allows the input comparators to be active during LPM with no polling current. In this case, the inputs can receive a digital signal on the order of the LPM clock cycle and wake-up on a change of state. This register is intended to be used for signals that are driven by an external chip and drive to 5.0 V.

**Table 30. Comparator only SP Register**

Register address	R/W	SPI data bits [23 - 0]							
[31-25]	[24]	bit 23	bit 22	bit 21	bit 20	bit 19	bit 18	bit 17	bit 16
0010_010	0/1	Unused							
Default on POR		0	0	0	0	0	0	0	0
		bit 15	bit 14	bit 13	bit 12	bit 11	bit 10	bit 9	bit 8
		Unused							
		0	0	0	0	0	0	0	0
		bit 7	bit 6	bit 5	bit 4	bit 3	bit 2	bit 1	bit 0
		SP7	SP6	SP5	SP4	SP3	SP2	SP1	SP0
		0	0	0	0	0	0	0	0
MISO return word		bit [23]	bit [22]	bits [21 - 0]					
0010_010[R/W]		FAULT STATUS	INTflg	Register Data					

## 7.10.16 Comparator only SG

The comparator only register allows the input comparators to be active during LPM with no polling current. In this case, the inputs can receive a digital signal on the order of the LPM clock cycle and wake-up on a change of state. This register is intended to be used for signals that are driven by an external chip and drive to 5.0 V.

**Table 31. Comparator only SG register**

Register address	R/W	SPI data bits [23 - 0]							
[31-25]	[24]	bit 23	bit 22	bit 21	bit 20	bit 19	bit 18	bit 17	bit 16
0010_011	0/1	Unused							
Default on POR		0	0	0	0	0	0	0	0
		bit 15	bit 14	bit 13	bit 12	bit 11	bit 10	bit 9	bit 8
		Unused		SG13	SG12	SG11	SG10	SG9	SG8
		0	0	0	0	0	0	0	0
		bit 7	bit 6	bit 5	bit 4	bit 3	bit 2	bit 1	bit 0
		SG7	SG6	SG5	SG4	SG3	SG2	SG1	SG0
		0	0	0	0	0	0	0	0
MISO return word		bit [23]	bit [22]	bits [21 - 0]					
0010_011[R/W]		FAULT STATUS	INTflg	Register Data					

## 7.10.17 LPM voltage threshold SP configuration

The 33978 is able to use different voltage thresholds to wake-up from LPM. When configured as SG, a Logic [0] means the input will use the LPM delta voltage threshold to determine the state of the switch. A Logic [1] means the input uses the Normal threshold (VICTHR) to determine the state of the switch. When configured as an SB, it only uses the 4.0 V threshold regardless the status of the LPM voltage threshold bit. The user must ensure that the correct current level is set to allow the crossing of the normal mode threshold (typ. 4.0 V)

**Table 32. LPM voltage threshold configuration SP register**

Register address	R/W	SPI data bits [23 - 0]							
[31-25]	[24]	bit 23	bit 22	bit 21	bit 20	bit 19	bit 18	bit 17	bit 16
0010_100	0/1	Unused							
Default on POR		0	0	0	0	0	0	0	0
		bit 15	bit 14	bit 13	bit 12	bit 11	bit 10	bit 9	bit 8
		Unused							
		0	0	0	0	0	0	0	0
		bit 7	bit 6	bit 5	bit 4	bit 3	bit 2	bit 1	bit 0
		SP7	SP6	SP5	SP4	SP3	SP2	SP1	SP0
		0	0	0	0	0	0	0	0
<b>MISO return word</b>		bit [23]	bit [22]	<b>bits [21 - 0]</b>					
0010_100[R/W]		FAULT STATUS	INTflg	Register Data					

## 7.10.18 LPM voltage threshold SG configuration

This means the input uses the LPM delta voltage threshold to determine the state of the switch. A Logic [1] means the input uses the Normal threshold to determine the state of the switch. The user must ensure that the correct current level is set to allow the crossing of the normal mode threshold (typ. 4.0 V)

**Table 33. LPM voltage threshold configuration SG register**

Register address	R/W	SPI data bits [23 - 0]							
[31-25]	[24]	bit 23	bit 22	bit 21	bit 20	bit 19	bit 18	bit 17	bit 16
0010_101	0/1	Unused							
Default on POR		0	0	0	0	0	0	0	0
		bit 15	bit 14	bit 13	bit 12	bit 11	bit 10	bit 9	bit 8
		Unused		SG13	SG12	SG11	SG10	SG9	SG8
		0	0	0	0	0	0	0	0
		bit 7	bit 6	bit 5	bit 4	bit 3	bit 2	bit 1	bit 0
		SG7	SG6	SG5	SG4	SG3	SG2	SG1	SG0
		0	0	0	0	0	0	0	0
<b>MISO return word</b>		bit [23]	bit [22]	<b>bits [21 - 0]</b>					
0010_101[R/W]		FAULT STATUS	INTflg	Register Data					

## 7.10.19 Polling current SP configuration

The normal polling current for LPM is 2.2 mA for SB channels and 1.0 mA for SG channels, A logic [0] selects the normal polling current for each individual channel. The user may choose to select the  $I_{WET}$  current value as defined in the wetting current level registers by writing a Logic [1] on this bit; this will result in higher LPM currents but may be used in cases when a higher polling current is needed.

**Table 34. Polling current configuration SP register**

Register address	R/W	SPI data bits [23 - 0]							
[31-25]	[24]	bit 23	bit 22	bit 21	bit 20	bit 19	bit 18	bit 17	bit 16
0010_110	0/1	Unused							
Default on POR		0	0	0	0	0	0	0	0
		bit 15	bit 14	bit 13	bit 12	bit 11	bit 10	bit 9	bit 8
		Unused							
		0	0	0	0	0	0	0	0
		bit 7	bit 6	bit 5	bit 4	bit 3	bit 2	bit 1	bit 0
		SP7	SP6	SP5	SP4	SP3	SP2	SP1	SP0
		0	0	0	0	0	0	0	0
<b>MISO return word</b>		bit [23]	bit [22]	bits [21 - 0]					
0010_110[R/W]		FAULT STATUS	INTflg	Register Data					

## 7.10.20 Polling current SG configuration

A Logic [0] selects the normal polling current for LPM =1.0 mA. The user may choose to select the  $I_{WET}$  current value as defined in the wetting current registers for LPM by writing a Logic [1] in this bit; this results in higher LPM currents but may be used in cases when a higher polling current is needed.

**Table 35. Polling current configuration SG register**

Register address	R/W	SPI data bits [23 - 0]							
[31-25]	[24]	bit 23	bit 22	bit 21	bit 20	bit 19	bit 18	bit 17	bit 16
0010_111	0/1	Unused							
Default on POR		0	0	0	0	0	0	0	0
		bit 15	bit 14	bit 13	bit 12	bit 11	bit 10	bit 9	bit 8
		Unused		SG13	SG12	SG11	SG10	SG9	SG8
		0	0	0	0	0	0	0	0
		bit 7	bit 6	bit 5	bit 4	bit 3	bit 2	bit 1	bit 0
		SG7	SG6	SG5	SG4	SG3	SG2	SG1	SG0
		0	0	0	0	0	0	0	0
<b>MISO return word</b>		bit [23]	bit [22]	bits [21 - 0]					
0010_111[R/W]		FAULT STATUS	INTflg	Register Data					

## 7.10.21 Slow polling SP

The normal polling rate is defined in the Low-power mode configuration register. If the user is able to poll at a slower rate (4x) the LPM current level decreases significantly. Setting the bit to [0] results in the input polling at the normal rate as selected. Setting the bit to [1] results in the input being polled at a slower frequency at 4x the normal rate.

**Table 36. Slow polling SP Register**

Register Address	R/W	SPI Data Bits [23 - 0]							
[31-25]	[24]	bit 23	bit 22	bit 21	bit 20	bit 19	bit 18	bit 17	bit 16
0011_000	0/1	Unused							
Default on POR		0	0	0	0	0	0	0	0
		bit 15	bit 14	bit 13	bit 12	bit 11	bit 10	bit 9	bit 8
		Unused							
		0	0	0	0	0	0	0	0
		bit 7	bit 6	bit 5	bit 4	bit 3	bit 2	bit 1	bit 0
		SP7	SP6	SP5	SP4	SP3	SP2	SP1	SP0
		0	0	0	0	0	0	0	0
MISO Return Word		bit [23]	bit [22]	bits [21 - 0]					
0011_000[R/W]		FAULT STATUS	INTflg	Register Data					

## 7.10.22 Slow polling SG

The normal polling rate is defined in the Low-power mode configuration register. If the user is able to poll at a slower rate (4x) the LPM current level decreases significantly. Setting the bit to [0] results in the input polling at the normal rate as selected. Setting the bit to [1] results in the input being polled at a slower frequency at 4x the normal rate.

**Table 37. Slow Polling SG Register**

Register address	R/W	SPI data bits [23 - 0]							
[31-25]	[24]	bit 23	bit 22	bit 21	bit 20	bit 19	bit 18	bit 17	bit 16
0011_001	0/1	Unused							
Default on POR		0	0	0	0	0	0	0	0
		bit 15	bit 14	bit 13	bit 12	bit 11	bit 10	bit 9	bit 8
		Unused		SG13	SG12	SG11	SG10	SG9	SG8
		0	0	0	0	0	0	0	0
		bit 7	bit 6	bit 5	bit 4	bit 3	bit 2	bit 1	bit 0
		SG7	SG6	SG5	SG4	SG3	SG2	SG1	SG0
		0	0	0	0	0	0	0	0
MISO return word		bit [23]	bit [22]	bits [21 - 0]					
0011_001[R/W]		FAULT STATUS	INTflg	Register Data					

## 7.10.23 Wake-up debounce SP

The IC is able to extend the time that the active polling takes place to ensure that a true change of state has occurred in LPM and reduce the chance that noise has impacted the measurement. If this bit is [0], the IC uses a voltage difference technique to determine if a switch has changed state. If this bit is set [1], the IC debounces the measurement by continuing to source the LPM polling current for an additional 1.2 ms and take the measurement based on the final voltage level. This helps to ensure that the switch is detected correctly in noisy systems.

**Table 38. Wake-up debounce SP register**

Register address	R/W	SPI data bits [23 - 0]							
[31-25]	[24]	bit 23	bit 22	bit 21	bit 20	bit 19	bit 18	bit 17	bit 16
0011_010	0/1	Unused							
Default on POR		0	0	0	0	0	0	0	0
		bit 15	bit 14	bit 13	bit 12	bit 11	bit 10	bit 9	bit 8
		Unused							
		0	0	0	0	0	0	0	0
		bit 7	bit 6	bit 5	bit 4	bit 3	bit 2	bit 1	bit 0
		SP7	SP6	SP5	SP4	SP3	SP2	SP1	SP0
		0	0	0	0	0	0	0	0
<b>MISO return word</b>		bit [23]	bit [22]	<b>bits [21 - 0]</b>					
0011_010[R/W]		FAULT STATUS	INTflg	Register Data					

## 7.10.24 Wake-up debounce SG

The IC is able to extend the time that the active polling takes place to ensure that a true change of state has occurred in LPM and reduce the chance that noise has impacted the measurement. If this bit is [0], the IC uses a voltage difference technique to determine if a switch has changed state. If this bit is set [1], the IC debounces the measurement by continuing to source the LPM polling current for an additional 1.2 ms and take the measurement based on the final voltage level. This helps to ensure that the switch is detected correctly in noisy systems.

**Table 39. Slow polling SG Register**

Register address	R/W	SPI data bits [23 - 0]							
[31-25]	[24]	bit 23	bit 22	bit 21	bit 20	bit 19	bit 18	bit 17	bit 16
0011_011	0/1	Unused							
Default on POR		0	0	0	0	0	0	0	0
		bit 15	bit 14	bit 13	bit 12	bit 11	bit 10	bit 9	bit 8
		Unused		SG13	SG12	SG11	SG10	SG9	SG8
		0	0	0	0	0	0	0	0
		bit 7	bit 6	bit 5	bit 4	bit 3	bit 2	bit 1	bit 0
		SG7	SG6	SG5	SG4	SG3	SG2	SG1	SG0
		0	0	0	0	0	0	0	0
<b>MISO return word</b>		bit [23]	bit [22]	<b>bits [21 - 0]</b>					
0011_011[R/W]		FAULT STATUS	INTflg	Register Data					

## 7.10.25 Enter low-power mode

Low-power mode (LPM) is used to reduce system quiescent currents. Low-power mode may be entered only by sending the Low-power command. When returning to Normal mode, all register settings is maintained.

The Enter Low-power mode register is write only and has the effect of going to LPM and beginning operation as selected (polling, interrupt timer). When returning form Low-power mode, the first SPI transaction will return the Fault Status and the intflg bit set to high, as well as the actual status of the Input pins.

**Table 40. Enter low-power mode command**

Register address	W	SPI data bits [23 - 0]
[31-25]	[24]	bits [23 - 16]
0011_100	1	0000_0000
		bits [15 - 8]
		0000_0000
		bits [7 - 0]
		0000_0000
MISO return word		-

## 7.10.26 AMUX control register

The analog voltage on switch inputs may be read by the MCU using the analog command ([Table 41](#)). Internal to the33978 is a 24-to-1 analog multiplexer. The voltage present on the selected input pin is buffered and made available on the AMUX output pin. The AMUX output pin is clamped to a maximum of  $V_{DDQ}$  volts regardless of the higher voltages present on the input pin. After an input has been selected as the analog, the corresponding bit in the next MISO data stream is logic [0].

Setting the current to wetting current (configurable) may be useful for reading sensor inputs. The MCU may change or update the analog select register via software at any time in Normal mode. The analog select defaults to no input.

**Table 41. Slow polling SG register**

Register address	R/W	SPI data bits [23 - 0]									
[31-25]	[24]	bit 23	bit 22	bit 21	bit 20	bit 19	bit 18	bit 17	bit 16		
0011_101	0/1	Unused									
Default on POR		0	0	0	0	0	0	0	0		
		bit 15	bit 14	bit 13	bit 12	bit 11	bit 10	bit 9	bit 8		
		Unused									
		0	0	0	0	0	0	0	0		
		bit 7	bit 6	bit 5	bit 4	bit 3	bit 2	bit 1	bit 0		
		Unused	asett0	asetl[5-0]							
		0	0	0	0	0	0	0	0		
MISO return word		bit [23]	bit [22]	bits [21 - 0]							
0011_101[R/W]		FAULT STATUS	INTflg	Register Data							

**Table 42. AMUX current select**

asett[0]	Zsource
0	hi Z (default)
1	$I_{WET}$



**Table 43. AMUX channel select**

asel 5	asel 4	asel3	asel 2	asel 1	asel 0	Analog channel select
0	0	0	0	0	0	No Input Selected
0	0	0	0	0	1	SG0
0	0	0	0	1	0	SG1
0	0	0	0	1	1	SG2
0	0	0	1	0	0	SG3
0	0	0	1	0	1	SG4
0	0	0	1	1	0	SG5
0	0	0	1	1	1	SG6
0	0	1	0	0	0	SG7
0	0	1	0	0	1	SG8
0	0	1	0	1	0	SG9
0	0	1	0	1	1	SG10
0	0	1	1	0	0	SG11
0	0	1	1	0	1	SG12
0	0	1	1	1	0	SG13
0	0	1	1	1	1	SP0
0	1	0	0	0	0	SP1
0	1	0	0	0	1	SP2
0	1	0	0	1	0	SP3
0	1	0	0	1	1	SP4
0	1	0	1	0	0	SP5
0	1	0	1	0	1	SP6
0	1	0	1	1	0	SP7
0	1	0	1	1	1	Temp Diode
0	1	1	0	0	0	Battery Sense

## 7.10.27 Read switch status

The Read switch status register is used to determine the state of each of the inputs and is read only. All of the inputs (SGn and SPn) are returned after the next command is sent. A Logic [1] means the switch is closed while a Logic [0] is an open switch.

Included in the status register are two more bits, the Fault Status bit and intflg bit. The Fault Status bit is a combination of the extended status bits and the wetting current fault bits. If any of these bits are set, the Fault Status bit is set. The intflg bit is set when an interrupt occurs on this device.

After POR, both the Fault Status bit and the intflg bit are set high to indicate an interrupt due to a POR occurred. The intflg bit will be cleared upon reading the Read Switch Status register, and the Fault Status bit will remain high until the Fault status register is read and thus the POR fault bit and all other fault flags are cleared.

The Fault Status and Intflg bits are semi-global flags, if a fault or an interrupt occurs, these bit will be returned after writing or reading any command, except for the SPICheck and the Wetting Current configuration registers, which use those bits to set/display the device configuration.

**Table 44. Read switch status command**

Register address	R	SPI data bits [23 - 0]							
[31-25]	[24]	bit 23	bit 22	bit 21	bit 20	bit 19	bit 18	bit 17	bit 16
0011_111	0	FAULT STATUS	INTflg	SP7	SP6	SP5	SP4	SP3	SP2
Default After POR		1	1	X	X	X	X	X	X
		bit 15	bit 14	bit 13	bit 12	bit 11	bit 10	bit 9	bit 8
		SP1	SP0	SG13	SG12	SG11	SG10	SG9	SG8
		X	X	X	X	X	X	X	X
		bit 7	bit 6	bit 5	bit 4	bit 3	bit 2	bit 1	bit 0
		SG7	SG6	SG5	SG4	SG3	SG2	SG1	SG0
	X	X	X	X	X	X	X	X	
MISO return word		bit [23]	bit [22]	bits [21-14]			bits [13-0]		
0011_1110		FAULT STATUS	INTflg	SP7 -SP0 Switch Status			SG13 - SG0 Switch Status		

The fault/status diagnostic capability consists of one internal 24 bit register. The content of the fault/status register is shown in [Table 45](#). Bits 0 – 21 shows the status of each input where logic [1] is a closed switch and logic [0] is an open switch. In addition to input status information, Fault status such as die over-temp, Hash fault, SPI errors, as well as interrupts are reported.

A SPI read cycle is initiated by a CS\_B logic '1' to '0' transition, followed by 32 SCLK cycles to shift the fault / status registers out the MISO pin. The INT\_B pin is cleared 1.0 ms after the falling edge of CS\_B. The fault is immediately set again if the fault condition is still present. The Fault Status bit sets any time a Fault occurs, and the Fault register ([Table 46](#)) must be read in order to clear the Fault status flag.

The intflg bit sets any time an interrupt event occurs (change of state on switch, any fault status bit gets set). Any SPI message that will return intflg bit will clear this flag (even if the event is still occurring, for example an overtemp, will cause an interrupt. The interrupt can be cleared but the chip will not interrupt again based on the overtemp until that fault has gone away).

**Table 45. MISO output register definition**

MISO Response Sends	Fault Status	INTflg	SP7	SP6	SP5	SP4	SP3	SP2	SP1	SP0	SG13	SG12	SG11	SG10	SG9	SG8	SG7	SG6	SG5	SG4	SG3	SG2	SG1	SG0

Bit 23 : Fault Status:

- 0 = No Fault
- 1 = Indicates a fault has occurred and should be viewed in the fault status register.

Bit 22 : Intflg:

- 0 = No Change of state
- 1 = Change of state detected.

Bit 21 – 0 : SPx /SGx input status:

- 0 = Open switch;
- 1 =Closed switch

## 7.10.28 Fault status register

To read the fault status bits the user should first send a message to the IC with the fault status register address followed by any given second command. The MISO response from the second command will contain the fault flags information.

**Table 46. Fault status register**

Register address	R	SPI data bits [23 - 0]									
[31-25]	[24]	bit 23	bit 22	bit 21	bit 20	bit 19	bit 18	bit 17	bit 16		
0100_001	0	Unused	INTflg	Unused							
Default After POR		0	1	0	0	0	0	0	0		
		bit 15	bit 14	bit 13	bit 12	bit 11	bit 10	bit 9	bit 8		
		Unused					SPI error	Hash Fault	Unused		
		0	0	0	0	0	X	X	0		
		bit 7	bit 6	bit 5	bit 4	bit 3	bit 2	bit 1	bit 0		
		UV	OV	TempFlag	OT	INT_B Wake	WAKE_B Wake	SPI Wake	POR		
	X	X	X	X	X	X	X	X			
MISO return word		bit [23]	bit [22]	bits [21-0]							
0100_0010		FAULT STATUS	INTflg	FAULT/FLAG BITS							

**Table 47. MISO response for fault status command**

Bit	Functions	Default value	Description
23	Unused	0	Unused
22	INTflg	X	Reports that an Interrupt has occurred, user should read the status register to determine cause. <ul style="list-style-type: none"> <li>Set: Various (SGx change of state, SPx change of state, Extended status bits).</li> <li>Reset: Clear of fault or read of Status register</li> </ul>
21-11	Unused	0	Unused
10	SPI error	X	Any SPI error generates a bit (Wrong address, incorrect modulo). <ul style="list-style-type: none"> <li>Set: SPI message error.</li> <li>Reset: Read fault status register and no SPI errors.</li> </ul>
9	Hash Fault	X	SPI register and hash mismatch. <ul style="list-style-type: none"> <li>Set: Mismatch between SPI registers and hash.</li> <li>Reset: No mismatch and SPI flag read.</li> </ul>
8	Unused	0	Unused
7	UV	X	Reports that low VBATP voltage was in undervoltage range <ul style="list-style-type: none"> <li>Set: Voltage drops below UV level.</li> <li>Reset: VBATP rises above UV level and flag read (SPI)</li> </ul>
6	OV	X	Report that the voltage on VBATP was higher than OV threshold <ul style="list-style-type: none"> <li>Set: Voltage at VBATP rises above overvoltage threshold.</li> <li>Reset: Overvoltage condition is over and flag read (SPI)</li> </ul>
5	Temp Flag	X	Temperature warning to note elevated IC temperature <ul style="list-style-type: none"> <li>Set: tLIM warning threshold is passed.</li> <li>Reset: Temperature drops below thermal warning threshold + hysteresis and flag read (SPI)</li> </ul>
4	OT	X	Tlim event occurred on the IC <ul style="list-style-type: none"> <li>Set: Tlim warning threshold is passed.</li> <li>Reset: Temperature drops below thermal warning threshold + hysteresis and flag read (SPI)</li> </ul>

**Table 47. MISO response for fault status command (continued)**

3	INT_B Wake	X	Part awakens via an external INT_B falling edge <ul style="list-style-type: none"> <li>• Set: INT_B Wakes the part from LPM (external falling edge)</li> <li>• Reset: flag read (SPI).</li> </ul>
2	WAKE_B Wake	X	Part awakens via an external WAKE_B falling edge <ul style="list-style-type: none"> <li>• Set: External WAKE_B falling edge seen</li> <li>• Reset: flag read (SPI).</li> </ul>
1	SPI Wake	X	Part awakens via a SPI message <ul style="list-style-type: none"> <li>• Set: SPI message wakes the IC from LPM</li> <li>• Reset: flag read (SPI).</li> </ul>
0	POR	X	Reports a POR event occurred. <ul style="list-style-type: none"> <li>• Set: Voltage at VBATP pin dropped below VBATP(POR) voltage</li> <li>• Reset: flag read (SPI)</li> </ul>

## 7.10.29 Interrupt request

The MCU may request an Interrupt pulse of duration 100  $\mu$ s by sending the Interrupt request command. After an Interrupt request commands, the 33978 returns the Interrupt request command word, as well as the Fault status and INTflg bits set if a fault/interrupt event occurred. Sending an interrupt request command does not set the INTflg bit itself.

**Table 48. Interrupt request command**

Register address	W	SPI data bits [23 - 0]		
[31-25]	[24]	bits [23 - 16]		
0100_011	1	0000_0000		
		bits [15 - 8]		
		0000_0000		
		bits [7 - 0]		
		0000_0000		
MISO return word	bit [23]	bit [22]	bits [21-0]	
0100_0111	FAULT STATUS	INTflg	0	

## 7.10.30 Reset register

Writing to this register causes all of the SPI registers to reset.

**Table 49. Reset command**

Register address	W	SPI data bits [23 - 0]		
[31-25]	[24]	bits [23 - 16]		
0100_100	1	0000_0000		
		bits [15 - 8]		
		0000_0000		
		bits [7 - 0]		
		0000_0000		
MISO return word	bit [23]	bit [22]	bits [21-0]	
0011_1110	FAULT STATUS	INTflg	Switch Status	

# 8 Typical applications

## 8.1 Application diagram



Figure 24. Typical application diagram

## 8.2 Bill of materials

Table 50. Bill of materials

Item	Quantity	Reference	Value	Description
1	24	C1, C2, C3, C4, C5, C6, C7, C8, C9, C10, C11, C12, C13, C14, C15, C16, C17, C18, C19, C20, C21, C22, C25, C27	0.1 µF	CAP CER 0.1 uF 100 V X7R 10 % 0603
2	2	C23, C24	1.0 nF	CAP CER 1000 PF 100 V 10 % X7R 0603
3	1	C26	100 µF	CAP ALEL 100 µF 50 V 20 % -- SMD
4	1	D1	-	DIODE RECT 3.0 A 50 V AEC-Q101 SMB
5	22	R1, R2, R3, R4, R5, R6, R7, R8, R9, R10, R11, R12, R13, R14, R15, R16, R17, R18, R19, R20, R21, R22	100 Ω	RES MF 100 Ω 0.5 W 1% 0805
6	1	R23	10 kΩ	RES MF 10 kΩ 0.5 W 5 % 0805 (optional)
7	1	R25	10 kΩ	RES MF 10 kΩ 0.5 W 5 % 0805
8	1	R24	1.0 kΩ	RES MF 1 kΩ 0.5 W 5 % 0805
9	1	U1	MC33978	IC MULTIPLE DETECTION SWITCH INTERFACE SOIC32

## 8.3 Abnormal operation

The 33978 could be subject to various conditions considered abnormal as defined within this section.

### 8.3.1 Reverse battery

This device with applicable external components will not be damaged by exposure to reverse battery conditions of -14 V. This test is performed for a period of one minute at 25 °C. In addition, this negative voltage condition does not force any of the logic level I/O pins to a negative voltage less than -0.6 V at 10 mA or to a positive voltage greater the 5.0 V. This insures protection of the digital device interfacing with this device.

### 8.3.2 Ground offset

The applicable driver outputs and/or current sense inputs are capable of operation with a ground offset of  $\pm 1.0$  V. The device will not be damaged by exposure to this condition and will maintain specified functionality.

### 8.3.3 Shorts to ground

All I/Os of the device that are available at the module connector are protected against shorts to ground with maximum ground offset considered (i.e. -1.0 V referenced to device ground or other application specific value). The device will not be damaged by this condition.

### 8.3.4 Shorts to battery

All I/Os of the device that are available at the module connector are protected against a short to battery (voltage value is application dependent, there may be cases where short to jump start or load dump voltage values are required). The device will not be damaged by this condition.

### 8.3.5 Unpowered shorts to battery

All I/Os of the device that are available at the module connector are protected against unpowered (battery to the module is open) shorts to battery per application specifics. The device will not be damaged by this condition, will not enable any outputs nor backfeed onto the power rails (VBATP, VDDQ) or the digital I/O pins.

### 8.3.6 Loss of module ground

The definition of a loss of ground condition at the device level is that all pins of the IC detects very low-impedance to battery. The nomenclature is suited to a test environment. In the application, a loss of ground condition results in all I/O pins floating to battery voltage, while all externally referenced I/O pins are at worst case pulled to ground. All applicable driver outputs and current sense inputs are protected against excessive leakage current due to loads that are referenced to an external ground (high-side drivers).

### 8.3.7 Loss of module battery

The loss of battery condition at the parts level is that the power input pins of the IC see infinite impedance to the battery supply voltage (depending upon the application) but there is some undefined impedance looking from these pins to ground. All applicable driver outputs and current sense inputs are protected against excessive leakage current due to loads that are referenced to an external battery connection (low-side drivers).

# 9 Packaging

## 9.1 Package mechanical dimensions

Package dimensions are provided in package drawings. To find the most current package outline drawing, go to [www.nxp.com](http://www.nxp.com) and perform a keyword search for the drawing's document number.

**Table 51. Packaging information**

Package	Suffix	Package outline drawing number
32-Pin SOICW-EP	EK	98ASA10556D
32-Pin QFN (WF-type)	ES	98ASA00656D
48-pin LQFP-EP	AE	98ASA00173D

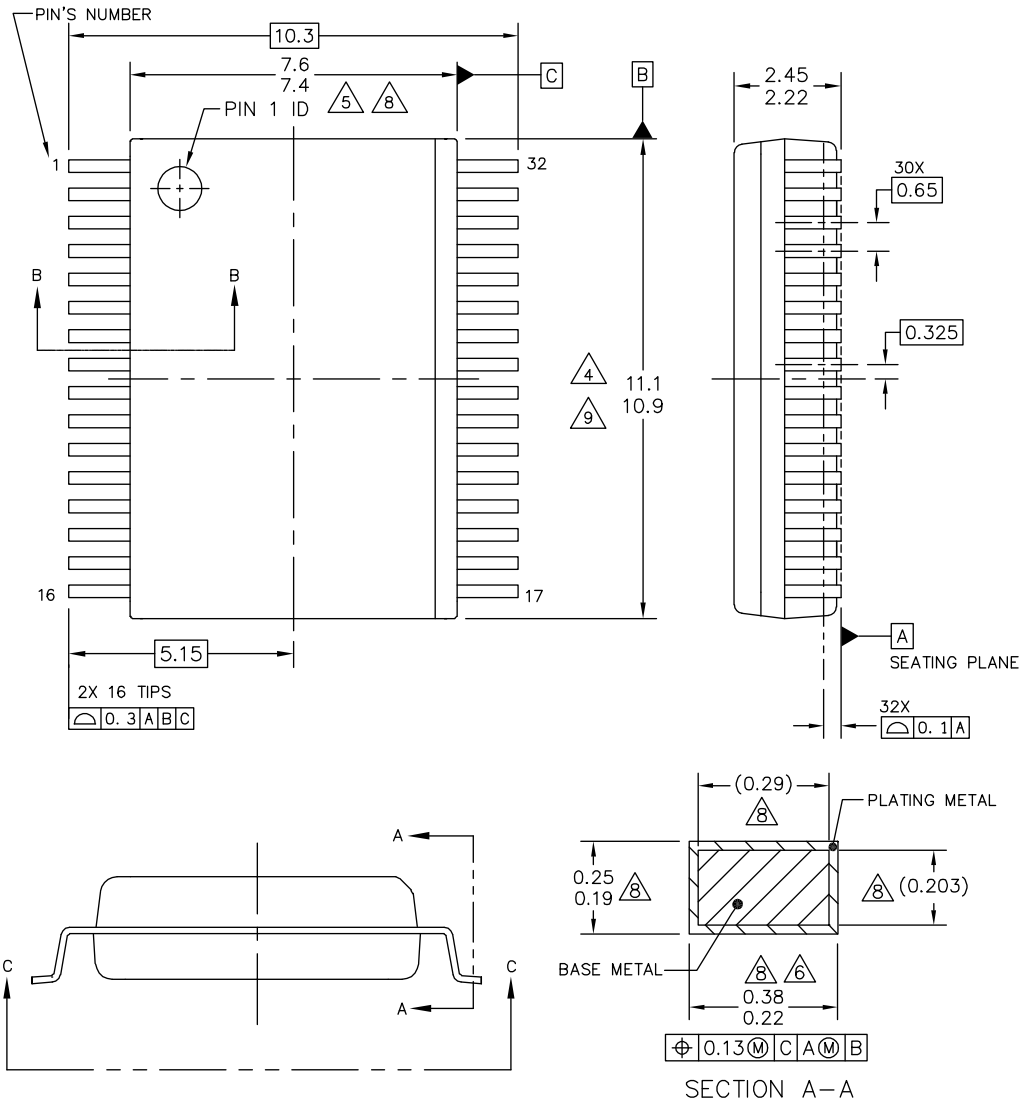

© NXP SEMICONDUCTORS N. V. ALL RIGHTS RESERVED	MECHANICAL OUTLINE	PRINT VERSION NOT TO SCALE
TITLE: 32LD SOIC W/B, 0.65 PITCH 4.7 X 4.7 EXPOSED PAD	DOCUMENT NO: 98ASA10556D	REV: F
	STANDARD: NON-JEDEC	
	SOT1746-3	15 JAN 2016



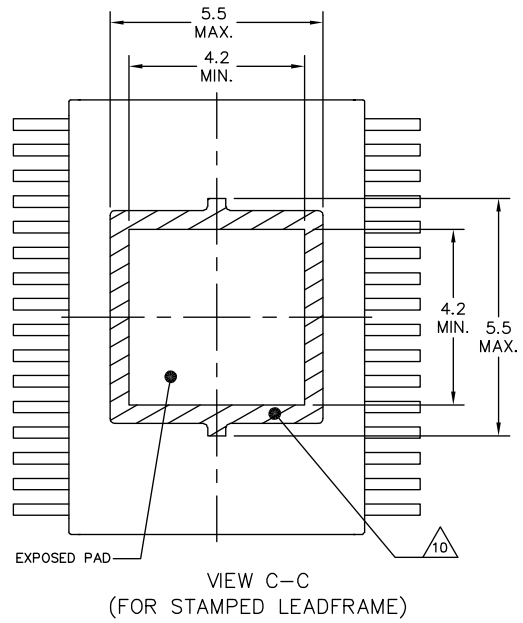
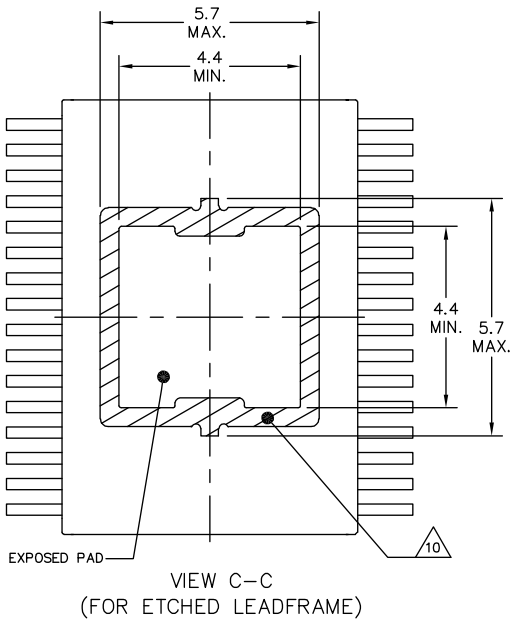
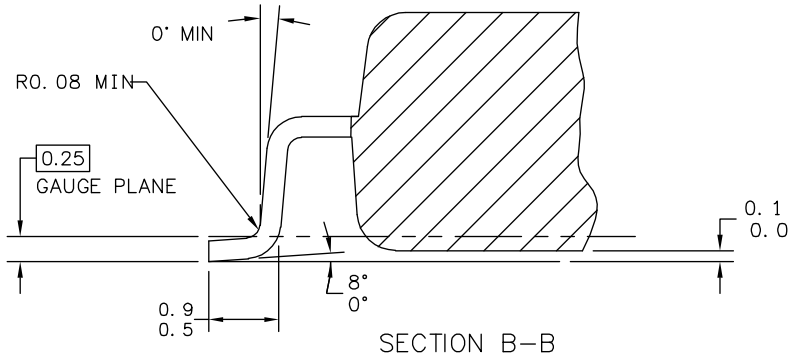

© NXP SEMICONDUCTORS N. V. ALL RIGHTS RESERVED	MECHANICAL OUTLINE	PRINT VERSION NOT TO SCALE
TITLE: 32LD SOIC W/B, 0.65 PITCH 4.7 X 4.7 EXPOSED PAD	DOCUMENT NO: 98ASA10556D	REV: F
	STANDARD: NON-JEDEC	
	SOT1746-3	15 JAN 2016



NOTES:

1. DIMENSIONS ARE IN MILLIMETERS.
2. DIMENSIONING AND TOLERANCING PER ASME Y14.5M-1994.
3. DATUMS B AND C TO BE DETERMINED AT THE PLANE WHERE THE BOTTOM OF THE LEADS EXIT THE PLASTIC BODY.
4. THIS DIMENSION DOES NOT INCLUDE MOLD FLASH, PROTRUSION OR GATE BURRS. MOLD FLASH, PROTRUSION OR GATE BURRS SHALL NOT EXCEED 0.15 MM PER SIDE. THIS DIMENSION IS DETERMINED AT THE PLANE WHERE THE BOTTOM OF THE LEADS EXIT THE PLASTIC BODY.
5. THIS DIMENSION DOES NOT INCLUDE INTER-LEAD FLASH OR PROTRUSIONS. INTER-LEAD FLASH AND PROTRUSIONS SHALL NOT EXCEED 0.25 MM PER SIDE. THIS DIMENSION IS DETERMINED AT THE PLANE WHERE THE BOTTOM OF THE LEADS EXIT THE PLASTIC BODY.
6. THIS DIMENSION DOES NOT INCLUDE DAMBAR PROTRUSION. ALLOWABLE DAMBAR PROTRUSION SHALL NOT CAUSE THE LEAD WIDTH TO EXCEED 0.4 mm. DAMBAR CANNOT BE LOCATED ON THE LOWER RADIUS OR THE FOOT. MINIMUM SPACE BETWEEN PROTRUSION AND ADJACENT LEAD SHALL NOT LESS THAN 0.07 mm.
7. EXACT SHAPE OF EACH CORNER IS OPTIONAL.
8. THESE DIMENSIONS APPLY TO THE FLAT SECTION OF THE LEAD BETWEEN 0.10 mm AND 0.3 mm FROM THE LEAD TIP.
9. THE PACKAGE TOP MAY BE SMALLER THAN THE PACKAGE BOTTOM. THIS DIMENSION IS DETERMINED AT THE OUTERMOST EXTREMES OF THE PLASTIC BODY EXCLUSIVE OF MOLD FLASH, TIE BAR BURRS, GATE BURRS AND INTER-LEAD FLASH, BUT INCLUDING ANY MISMATCH BETWEEN THE TOP AND BOTTOM OF THE PLASTIC BODY.
10. HATCHED AREA TO BE KEEP-OUT ZONE FOR PCB ROUTING.

© NXP SEMICONDUCTORS N. V. ALL RIGHTS RESERVED	MECHANICAL OUTLINE	PRINT VERSION NOT TO SCALE
TITLE: 32LD SOIC W/B, 0.65 PITCH 4.7 X 4.7 EXPOSED PAD	DOCUMENT NO: 98ASA10556D	REV: F
	STANDARD: NON-JEDEC	
	SOT1746-3	15 JAN 2016

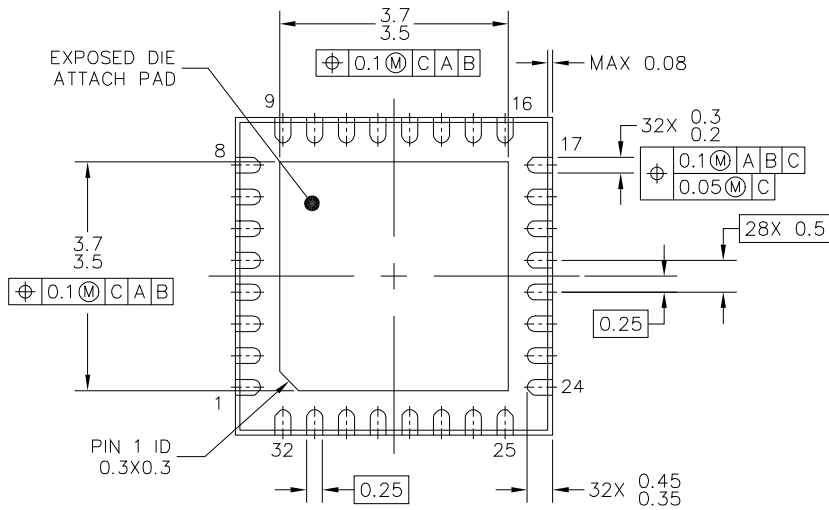
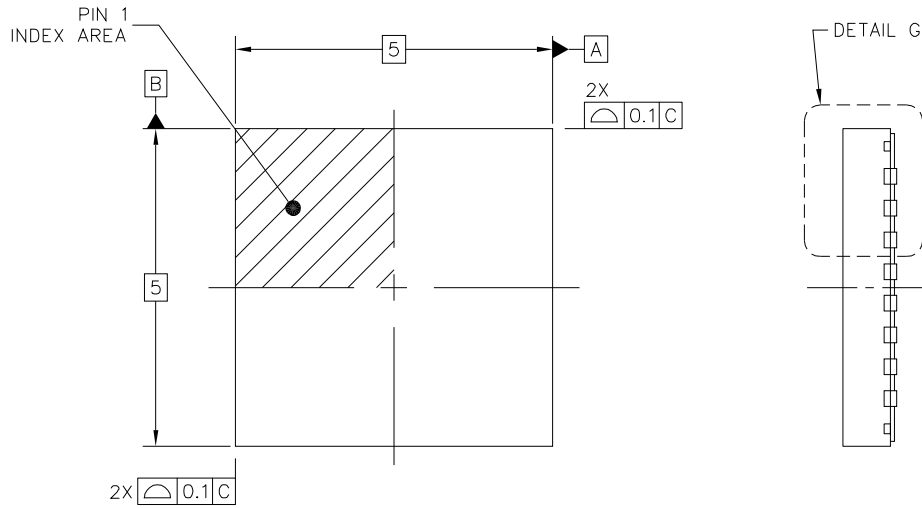

© NXP SEMICONDUCTORS N.V. ALL RIGHTS RESERVED	<b>MECHANICAL OUTLINE</b>	PRINT VERSION NOT TO SCALE	
TITLE: QFN, THERMALLY ENHANCED, 5 X 5 X 0.85, 0.5 PITCH, 32 TERMINAL		DOCUMENT NO: 98ASA00656D	REV: A
		STANDARD: NON-JEDEC	
		SOT617-19	13 JAN 2016

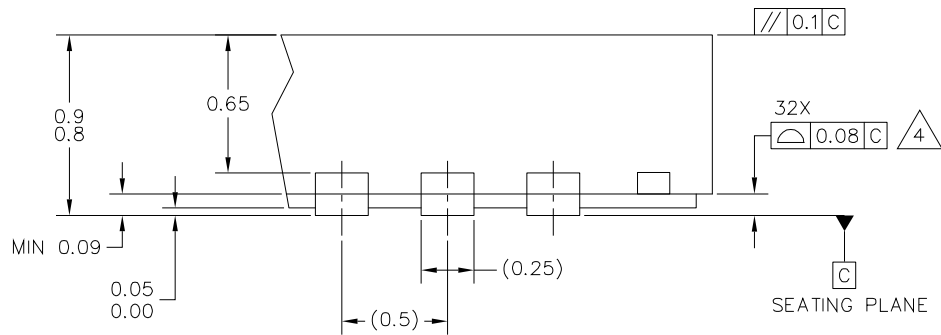

DETAIL G  
VIEW ROTATED 90°CW

© NXP SEMICONDUCTORS N.V. ALL RIGHTS RESERVED	MECHANICAL OUTLINE	PRINT VERSION NOT TO SCALE	
TITLE: QFN, THERMALLY ENHANCED, 5 X 5 X 0.85, 0.5 PITCH, 32 TERMINAL	DOCUMENT NO: 98ASA00656D	REV: A	
	STANDARD: NON-JEDEC		
	SOT617-19	13 JAN 2016	



NOTES:

1. ALL DIMENSIONS ARE IN MILLIMETERS.
2. DIMENSIONING AND TOLERANCING PER ASME Y14.5M-1994.
3. THIS IS A NON-JEDEC REGISTERED PACKAGE.
4.  COPLANARITY APPLIES TO LEADS AND DIE ATTACH FLAG.
5. MIN. METAL GAP SHOULD BE 0.2 MM.

© NXP SEMICONDUCTORS N.V. ALL RIGHTS RESERVED	<b>MECHANICAL OUTLINE</b>	PRINT VERSION NOT TO SCALE	
TITLE: QFN, THERMALLY ENHANCED, 5 X 5 X 0.85, 0.5 PITCH, 32 TERMINAL		DOCUMENT NO: 98ASA00656D	REV: A
		STANDARD: NON-JEDEC	
		SOT617-19	13 JAN 2016

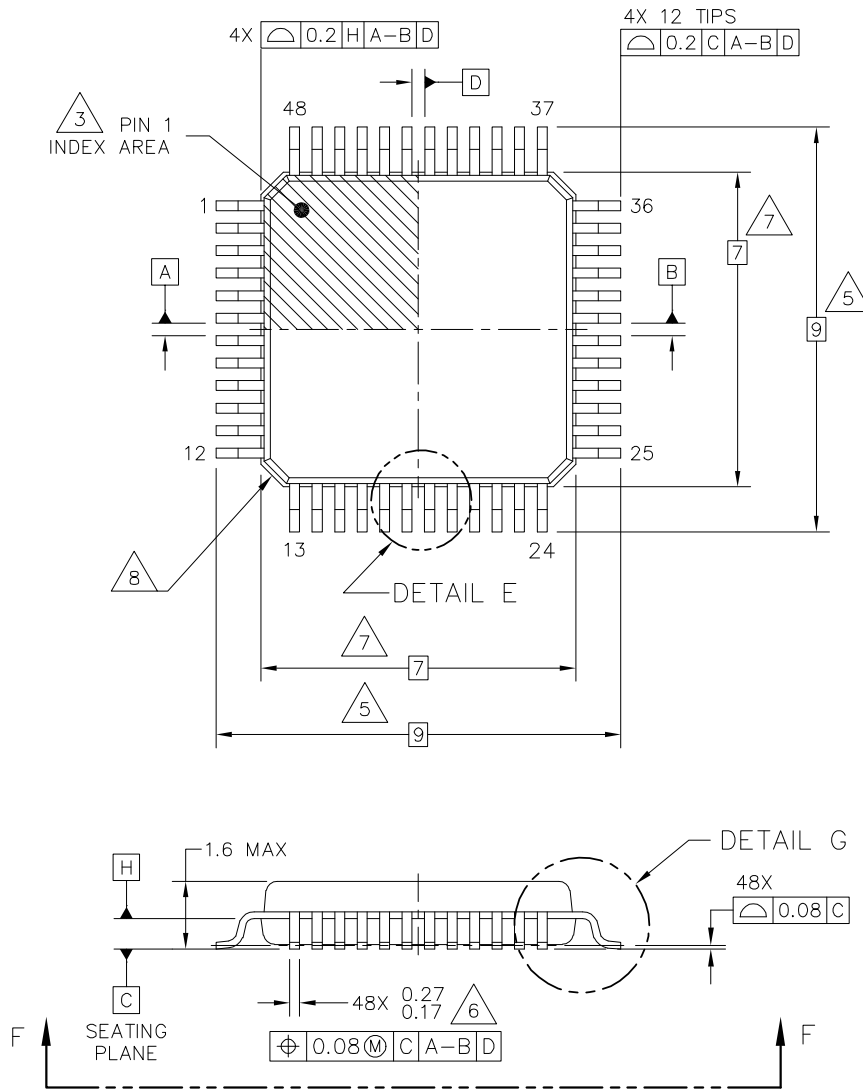

© NXP SEMICONDUCTORS N.V. ALL RIGHTS RESERVED

DATE: 14 DEC 2017

MECHANICAL OUTLINE PRINT VERSION NOT TO SCALE	STANDARD: JEDEC MS-026 BBC	DRAWING NUMBER: SOT1571-1	REVISION: F	PAGE: 1 OF 7
--	-------------------------------	------------------------------	----------------	-----------------

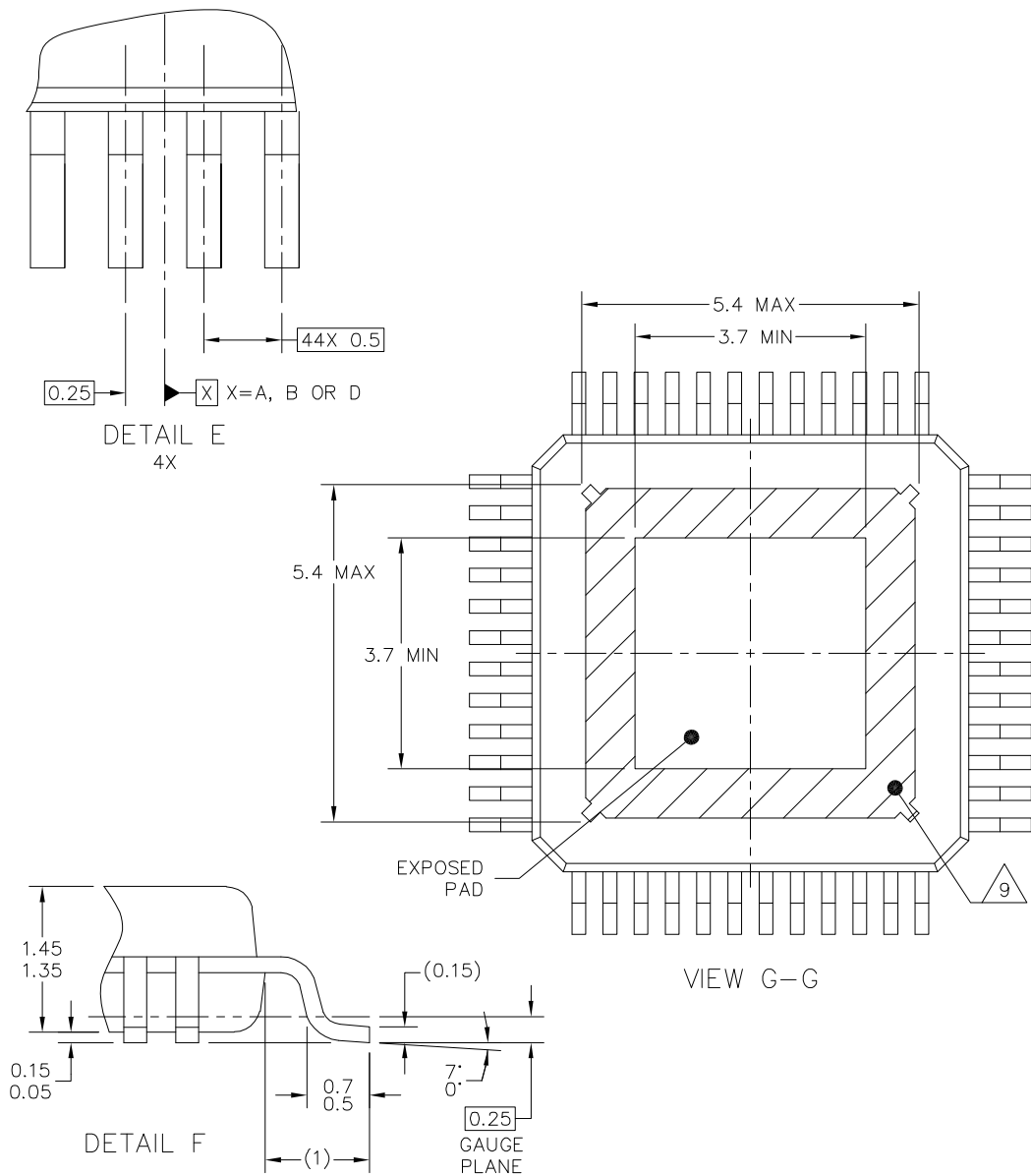

© NXP SEMICONDUCTORS N.V. ALL RIGHTS RESERVED

DATE: 14 DEC 2017

MECHANICAL OUTLINE PRINT VERSION NOT TO SCALE	STANDARD: JEDEC MS-026 BBC	DRAWING NUMBER: SOT1571-1	REVISION: F	PAGE: 2 OF 7
--	-------------------------------	------------------------------	----------------	-----------------

NOTES:

1. DIMENSIONS ARE IN MILLIMETERS.
2. DIMENSIONING AND TOLERANCING PER ASME Y14.5M-1994.
3. PIN 1 FEATURE SHAPE, SIZE AND LOCATION MAY VARY.
4. DATUMS A, B AND D TO BE DETERMINED AT DATUM PLANE H.
5. DIMENSION TO BE DETERMINED AT SEATING PLANE C.
6. THIS DIMENSION DOES NOT INCLUDE DAMBAR PROTRUSION. ALLOWABLE DAMBAR PROTRUSION SHALL NOT CAUSE THE LEAD WIDTH TO EXCEED THE UPPER LIMIT BY MORE THAN 0.08MM AT MAXIMUM MATERIAL CONDITION. DAMBAR CANNOT BE LOCATED ON THE LOWER RADIUS OR THE FOOT. MINIMUM SPACE BETWEEN PROTRUSION AND ADJACENT LEAD SHALL NOT BE LESS THAN 0.07MM.
7. THIS DIMENSION DOES NOT INCLUDE MOLD PROTRUSION. ALLOWABLE PROTRUSION IS 0.25MM PER SIDE. THIS DIMENSION IS MAXIMUM PLASTIC BODY SIZE DIMENSION INCLUDING MOLD MISMATCH.
8. EXACT SHAPE OF EACH CORNER IS OPTIONAL.
9. HATCHED AREA TO BE KEEP OUT ZONE FOR PCB ROUTING.



© NXP SEMICONDUCTORS N.V. ALL RIGHTS RESERVED

DATE: 14 DEC 2017

MECHANICAL OUTLINE PRINT VERSION NOT TO SCALE	STANDARD: JEDEC MS-026 BBC	DRAWING NUMBER: SOT1571-1	REVISION: F	PAGE: 6 OF 7
--	-------------------------------	------------------------------	----------------	-----------------



# 10 Reference section

**Table 52. 33978 reference documents**

Reference	Description
CDF-AEC-Q100	Stress Test Qualification For Automotive Grade Integrated Circuits
Q-1000	Qualification Specification for Integrated Circuits
SQ-1001	Specification Conformance
ISO 7637	Electrical Disturbances from Conduction and Coupling
ISO 61000	Electromagnetic Compatibility

# 11 Revision history

Revision	Date	Description of changes
1.0	3/2014	<ul style="list-style-type: none"> <li>Initial release</li> </ul>
2.0	3/2014	<ul style="list-style-type: none"> <li>Removed Z from part numbers PCZ33978EK and PCZ33978ES in the <a href="#">Orderable part variations</a> table</li> </ul>
3.0	12/2014	<ul style="list-style-type: none"> <li>Major formatting and information arrangement</li> <li>Updated <a href="#">Figure 1. 33978 simplified application diagram</a>, removed CS_B pull-up resistor, not needed.</li> <li>Added Industrial Part numbers MC34978EK and MC34978ES to <a href="#">Table 1</a></li> <li><a href="#">Table 3</a> Clarified Switch Input Range specification (not a differential voltage between inputs and VBATP)</li> <li><a href="#">Table 3</a> Reduced Human Body Model (HBM) (VBATP versus GND) to 2500 V</li> <li><a href="#">Table 3</a> V<sub>ESD6-2</sub> Series resistor corrected to 50 Ω, Added missing C<sub>ZAP</sub> and R<sub>ZAP</sub> conditions</li> <li><a href="#">Table 4</a> Updated Thermal Resistance specification</li> <li>Added <a href="#">Figure 11. Functional block diagram</a></li> <li>Added <a href="#">Figure 12. Battery voltage range</a></li> <li>Added <a href="#">Figure 6. Glitch filter and interrupt delay timers</a> and <a href="#">Figure 7. Interrupt pulse timer</a></li> <li>Updated POR minimum specification to 2.7 V (previous 2.9 V)</li> <li>Updated V<sub>BATP</sub> Normal mode maximum supply current to 12 mA (previous 8.0 mA)</li> <li>Updated V<sub>DDQ</sub> undervoltage threshold maximum to 2.8 V (previous 2.7 V)</li> <li>Updated sustain current at low battery to 2.4 mA (previous 2.0 mA)</li> <li>Added a specification to cover the Normal mode switch detection threshold hysteresis.</li> <li>Updated minimum limit on Switch detection threshold in LPM to 80 mV</li> <li>Updated minimum ratio for switch threshold at low battery to 0.55x (previous 0.8x)</li> <li>Fixed typo on Input threshold specifications to VDD*0.25 and VDD*0.7</li> <li>Updated the INT_B VOL maximum level to 0.5 V (previous 0.4 V)</li> <li>Updated limits on the POR to Active time to 250 μs (min) to 450 μs (max) (previous min was 40 μs)</li> <li>Clarified Operating voltage range (4.5 V to 28 V)</li> <li>Corrected WAKE_B Max rating to 40 V.</li> <li>Added <a href="#">Figure 20. SPI write operation</a> and <a href="#">Figure 21. SPI read operation</a></li> <li>Added <a href="#">Table 7.10.1. SPI check</a></li> <li>Corrected Rb/W bits on <a href="#">Table 11</a> From 1/0 to 0/1</li> <li>Clarified SPI Read/write operation and SPI registers information.</li> <li>Updated VBATP(POR) maximum voltage to 3.8 V.</li> <li>Updated VBATP under voltage hysteresis minimum voltage to 250 mV</li> <li>Updated VBATP low-power mode supply current to 40 uA</li> <li>Input logic voltage threshold WAKE_B typical value added at 1.25 V, max value updated to 1.7 V</li> <li>Added new Specification for WAKE_B input logic hysteresis.</li> <li>Clarified AMUX accuracy and Coefficient accuracy specifications, added <a href="#">Figure 5. Divide by 6 coefficient accuracy</a>.</li> <li>Update internal pull-up resistance to 270 KΩ (INT_B, WAKE_B, CS_B)</li> <li>Low-power mode oscillator frequency centered at 192 KHz with +/- 15% tolerance.</li> <li>Updated all timing specs derived from the 192 kHz oscillator (Low-power mode)</li> <li>Added SBPOLLTIME (bit 13) selection functionality on <a href="#">7.10.2, "Device configuration register"</a></li> <li>Added SB Tactive Polling time specification (58 μs or 1.2 ms Typical)</li> <li><a href="#">Table 6</a> Clarified wetting current specification for SB and SG channels.</li> <li>SB sustain Current and Low-power mode polling current SB Typical value centered at 2.2mA, Min = 1.75 mA and Max = 2.65 mA, (+/- 20% tolerance).</li> <li>Wetting current matching, Max value updated to 6%</li> <li>Updated Switch detection Threshold in Low Voltage maximum value to 4.3 V.</li> <li>Added <a href="#">Figure 23. Pulsed/continuous wetting current configuration</a></li> <li>Removed section (Electrical Test requirement, Stress testing, and EMC consideration)</li> </ul>

Revision	Date	Description of changes
4.0	12/2014	<ul style="list-style-type: none"> <li>Changed <math>V_{ESD1-2}</math> to <math>\pm 2000</math></li> <li>Changed <math>I_{SUSSE}</math> max. value to 2.85 mA</li> <li>Changed <math>I_{ACTIVEPOLLSB}</math> max. value to 2.85 mA</li> <li>Changed PC33978EK and PC34978EK parts to MC in the <a href="#">Orderable part variations</a> table</li> </ul>
5.0	8/2015	<ul style="list-style-type: none"> <li>Deleted PC33978ES and PC34978ES part numbers</li> <li>Updated case outline</li> <li>Added new part numbers MC33978AEK, MC33978AES, MC34978AEK, and MC34978AES to the <a href="#">Orderable part variations</a> table</li> <li>Updated AMUX specification for QFN package</li> <li>Added thermal characteristics for QFN package</li> <li>Updated VBATP HBM specification to 4.0 KV</li> </ul>
	8/2015	<ul style="list-style-type: none"> <li>Added additional line to <math>V_{ESD1-2}</math> spec in <a href="#">Table 3</a> to show the max. value for MC33978/MC34978 and MC33978A/MC34978A</li> </ul>
	8/2016	<ul style="list-style-type: none"> <li>Updated to NXP document form and style</li> </ul>
6.0	2/2017	<ul style="list-style-type: none"> <li>Added note <sup>(4)</sup> to switch input voltage range in <a href="#">Table 3</a></li> </ul>
7.0	8/2017	<ul style="list-style-type: none"> <li>Added a new parameter <math>t_{CSB\_WAKEUP}</math> to <a href="#">Table 7</a></li> <li>Updated the dynamic electrical characteristics condition statement in <a href="#">Table 7</a> (changed "VBATP = 4.5 V to 28 V" to "VBATP = 6.0 V to 28 V")</li> </ul>
8.0	7/2018	<ul style="list-style-type: none"> <li>Changed document status from Advance Information to Technical Data</li> </ul>
9.0	1/2021	<ul style="list-style-type: none"> <li>Updated as per CIN 2021010101 <ul style="list-style-type: none"> <li>Added MC33978AAE part number to <a href="#">Table 1</a></li> <li>Added <a href="#">Figure 4</a> (LQFP pinout diagram)</li> <li>Added LQFP-48 pin definition to <a href="#">Table 2</a></li> <li>Added package outline drawing (98ASA00173D)</li> </ul> </li> </ul>

**How to Reach Us:****Home Page:**[NXP.com](http://www.nxp.com)**Web Support:**<http://www.nxp.com/support>

Information in this document is provided solely to enable system and software implementers to use NXP products.

There are no expressed or implied copyright licenses granted hereunder to design or fabricate any integrated circuits based on the information in this document. NXP reserves the right to make changes without further notice to any products herein.

NXP makes no warranty, representation, or guarantee regarding the suitability of its products for any particular purpose, nor does NXP assume any liability arising out of the application or use of any product or circuit, and specifically disclaims any and all liability, including without limitation, consequential or incidental damages. "Typical" parameters that may be provided in NXP data sheets and/or specifications can and do vary in different applications, and actual performance may vary over time. All operating parameters, including "typicals," must be validated for each customer application by the customer's technical experts. NXP does not convey any license under its patent rights nor the rights of others. NXP sells products pursuant to standard terms and conditions of sale, which can be found at the following address:

<http://www.nxp.com/terms-of-use.html>.

NXP, the NXP logo, Freescale, the Freescale logo and SMARTMOS are trademarks of NXP Semiconductors B.V.

All other product or service names are the property of their respective owners. All rights reserved.

© NXP B.V. 2021.

Document Number: MC33978

Rev. 9

1/2021

