

BB-485COSR

RS-232 to RS-485 Serial Converter



Introduction

Model BB-485COSR converts unbalanced, full-duplex RS-232 signals to balanced full-duplex (4-wire) or half-duplex (2-wire) RS-485 signals.

The RS-232 port has a female DB25S connector with pins 2 (TD input) and 3 (RD output) supported. Protective Ground (pin 1) and Signal Ground (pin 7) are also passed through. Pins 4 (RTS) and 5 (CTS) are tied together. Pins 6 (DSR), 8 (CD), and 20 (DTR) are tied together, but not passed through the converter.

The RS-485 port has a male DB25P connector with Send Data outputs on pins 2 and 14, and Receive Data inputs on pins 3 and 16, or 5 and 17. No special software is needed since the RS-485 driver is enabled by the first transition on the RS-232 side of the Transmit Data line (Pin 2). Any transmission on the TD line keeps the RS-485 driver enabled by preventing the monostable multivibrator from timing out. The transmitter is disabled approximately 1 ms after the last transmitted character. This 1 ms timeout allows continuous transmission of data at 9600 baud or higher.

A 12 Vdc external power supply is required (not included, sold separately).

Table 1. Component Replacements for Changing Baud Rate Timeouts

Baud Rate	Time (ms)	Resistor (R6) (Ohms)	Capacitor (C7) (mfd)
300	33.3	330K	0.1
600	16.6	160K	0.1
1200	8.33	820K	0.01
2400	4.16	430K	0.01
4800	2.08	200K	0.01
9600	1.04	100K	0.01
19200	.520	56K	0.01
38400	0.260	27K	0.01
57600	0.176	16K	0.01
115200	0.0868	8.2K	0.01

Features

- Converts RS-232 TD and RD to balanced RS-485
- Extend RS-232 data signals up to 1.2 km (4000 ft)
- Data rate: up to 115.2 kbps baud
- Quick, inline installation
- Automatic send data control – no software needed
- 12 Vdc power supply required (not included, sold separately)

Ordering Information

Model No.	RS-232	RS-485	Output
BB-485COSR	DB25 Female	DB25 Male	RS-485 4-wire full-duplex or RS-485 2-wire half-duplex

Accessories – Sold Separately

BB-SMI6B12V-P230C1 – Power Supply, 12 Vdc, 6 W, 2.5mm plug, international AC input, international AC blades (NATAM, EU, UK, Australia, China)

Interconnection Diagram

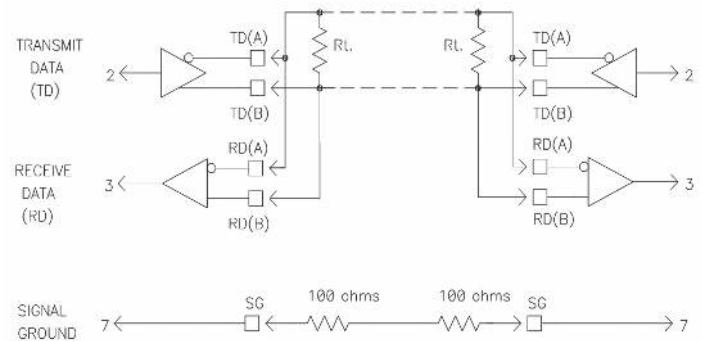

Specifications

Serial Technology	
Data Rate	115.2 Kbps, maximum
RS-232 Connector	DB25 female
RS-422 Connector	DB25 male
Signals	Converts RS-232 to RS-485
Operation	2-wire half-duplex or 4-wire full-duplex
Biasing Resistors	4.7 Ohms
Termination	None
Power	
Source / Requirement	12 Vdc, external power supply (required, not included, sold separately)
Mechanical	
Dimensions	5.4 x 6.2 x 1.5 cm (2.1 x 2.4 x 0.6 in)
Environmental	
Operating Temperature	0 to +70 °C (+32 to +158 °F)
Storage Temperature	-40 to +85 °C (-40 to +185 °F)
Operating Humidity	0-95%, non-condensing

Regulatory – Approvals / Standards / Directives	
FCC, CE	
CE – Directives	2014/30/EU – Electromagnetic Compatibility Directive (ECD) 2011-65/EU – Amended by (EU) 2015/863 Reduction of Hazardous Substances Directive (RoHS) 2012/19/EU – Waste Electrical and Electronic Equipment (WEEE)
CE – Standards	EN 55032 Class B – Electromagnetic Compatibility of Multimedia Equipment – Emission Requirements EN 55024 - Information Technology Equipment - Immunity Characteristics – Limits and Methods of Measurement
Other Standards	EN 61000-6-3 + A1 – Generic Emission Standard for Residential, Commercial and Light-industrial Environments (Class B) EN 61000-6-2 – Generic Immunity Standard for Industrial Environments

Schematic

